

Assembly Instructions

Important before assembly:

Read these instructions carefully before assembling or using the product.

Please check the contents of the boxes before attempting to assemble this product. The instructions will have a checklist of parts and fittings.

Assemble the product as close to its intended final location/room as possible.

Health & Safety:

This product or some parts of this product will be heavy. Please use an assistant when lifting.

Please keep small parts out of reach of children.

Always use on a level, even surface.

DO NOT jump on the product or any of its parts.

DO NOT use this product if any parts are missing, damaged or worn.

DO NOT use this product unless all fixings are secured.

Further instructions are on the following pages.

Please keep these instructions for future reference.



This product or some parts of this product will be heavy. Please use an assistant when lifting.



Never drag or push the pieces across a hard or stone floor as this will cause damage to the joints. Use a carpet or a rug for extra care.



If you have problems assembling or have damaged or missing pieces, please contact our customer services (details at the back of these instructions)

Components of Carton 1

(A) Footboard x 1

TV Mechanism
pre-fixed in the foot end

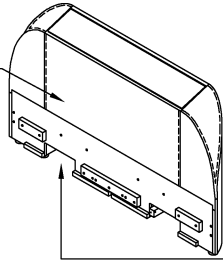

Hardware Box

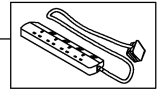
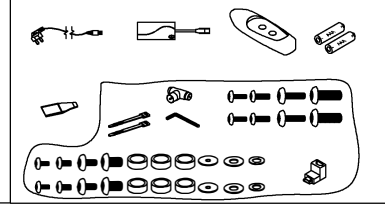

Component of Carton 2

(B) Side Rail-1 x 1

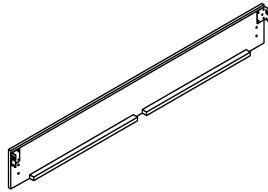

(C) Side Rail-2 x 1

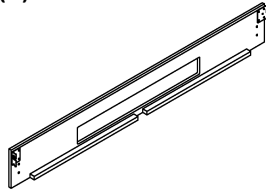

(D) Head End Panel x 1

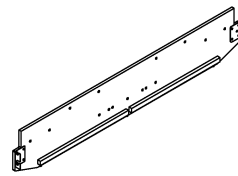

(E) Bottom Cross Rail (Long) x 1

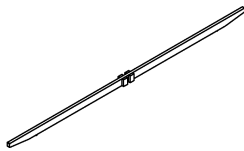

(F) Bottom Cross Rail (Short) x 2

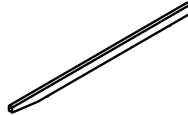

Hardware
Bag

Components of Carton 3

(G-1) Base Panel Left
x 1 (Head End)

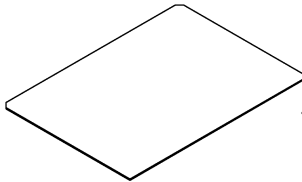

(G-2) Base Panel
Right x 1 (Head End)

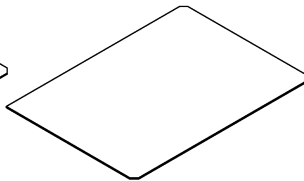

(H) Base Panel Right
x 1 (Foot End)

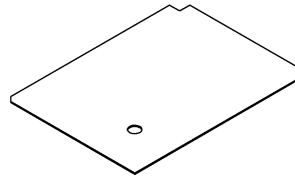

(I) Base Panel Left x 1
(Foot End)

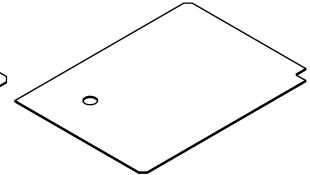

Components of Carton 4

(J) Lift Base -1 x 1

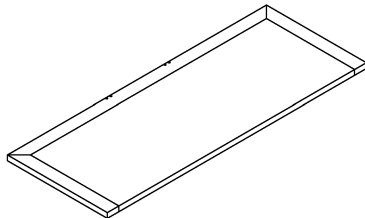

(K) Lift Base -2 x 1

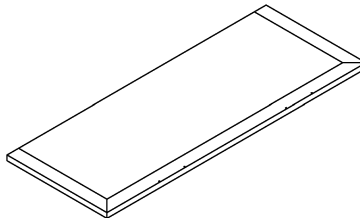

Components of Carton 5

(L) Lift Up Mechanism-1 x 1

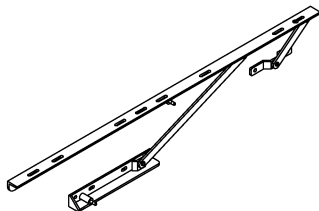

(M) Lift Up Mechanism-2 x 1

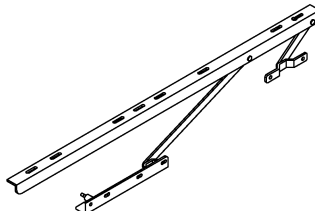

Hardware List (in Carton 1)

**(O) M8 x 25mm
x 10 (Pre-Installed)**



**(P) M8 x 18mm
x 6 (Pre-Installed)**



Hardware List (in Carton 2)

**(Q) #8 x 1-1/4"
x 16**

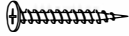

**(R) 3 X 40 X 86mm
x 4**

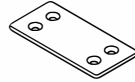

**(S) Strap Handle
x 2**



**(T) M8 x 13mm
x 4**



**(U) Gas Spring
x 2**



*** DOUBLE 650N
* KING 800N
* SUPER KING 1100N**

**(V) M6 x 20mm
x 4**



**(W) M6 x 16mm
x 4**



**(X) Ø5 x 80 x 200mm
x 2**



**(Y) Screw Driver
x 1**



**(Z) Allen Key (M4)
x 1**



**(AA) Spanner
x 1**

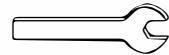

**(AB) Rubber Stopper
Ø46 X 50mm
x 4**



**(AC) M8 x 18mm
x 4**



Hardware List (in Carton 4)

**(AD) M6 x 20mm
x 14 (Pre-Installed)**



**(AE) M6 x 16mm
x 12 (Pre-Installed)**



Step 1

- Before assembly please decide which side you require the "DVD / Media Compartment "Part C" side rail with opening will need to be placed at that side
- Loosen the bolts located in the chosen head end. (Note: only loosen the bolts Do NOT remove them.)
- Hook the side rail over the bolts as shown.
- Repeat the action on the opposite side.

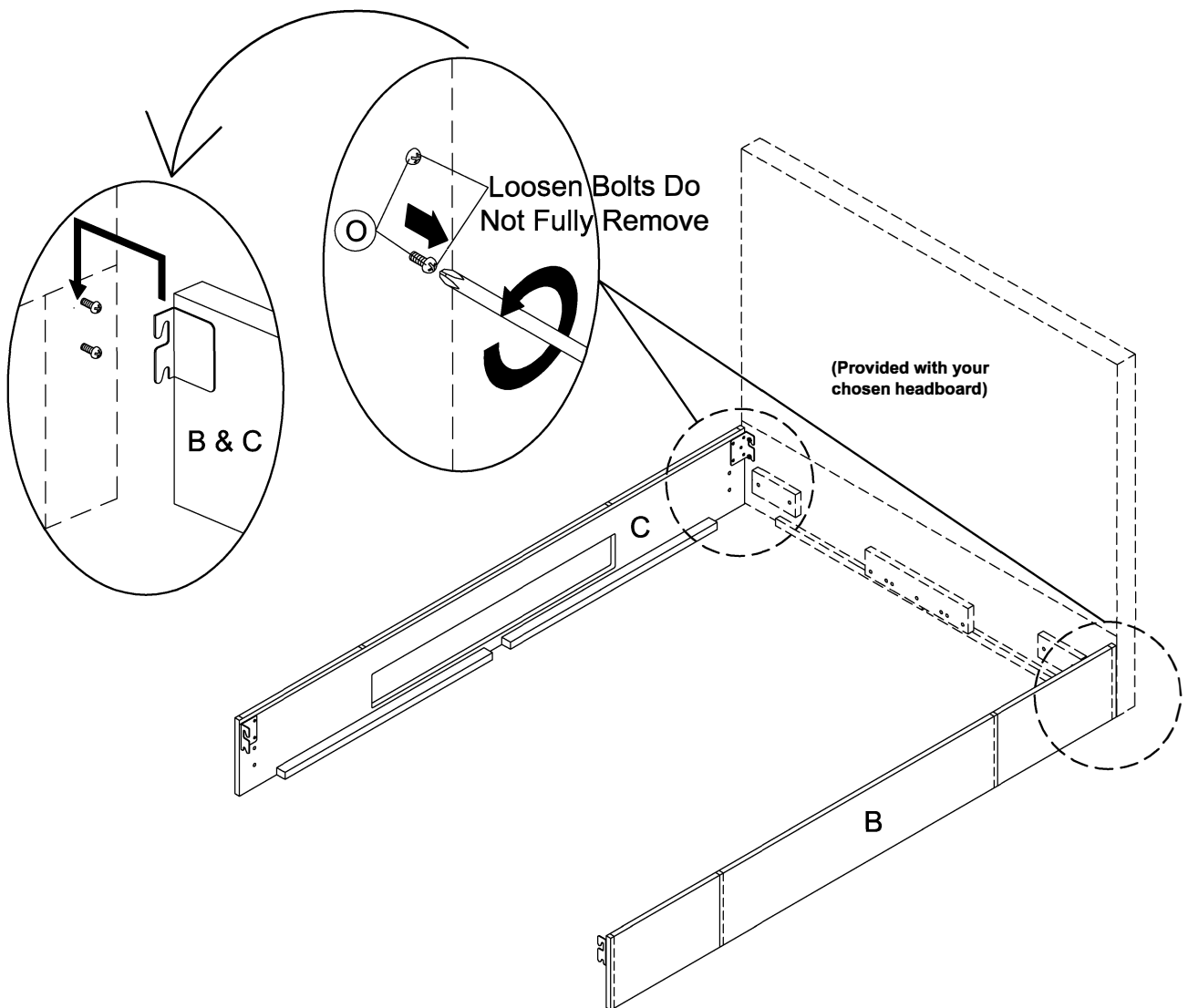

Step 2

- Carefully remove the foot end from carton 1, remove the Hardware Box and all extra transportation packaging from inside.
- To do this you will need to gently lay the foot end on it's back. Before doing so please ensure the area is completely free of anything that may cause damage or press into the fabric. Place a protective cover on the floor to avoid possible damage.
- The controls and hardware are held in place by string please carefully cut these and remove.

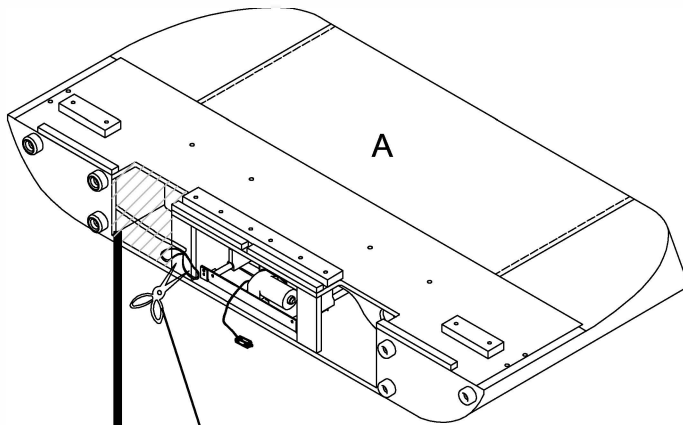

CAUTION:
PLEASE USE SCISSORS TO CUT THE STRING.
TAKE CARE WHEN REMOVING THE ACCESSORY BOXES NOT TO CATCH YOUR HANDS ON THE SIDES.

Hardware Box

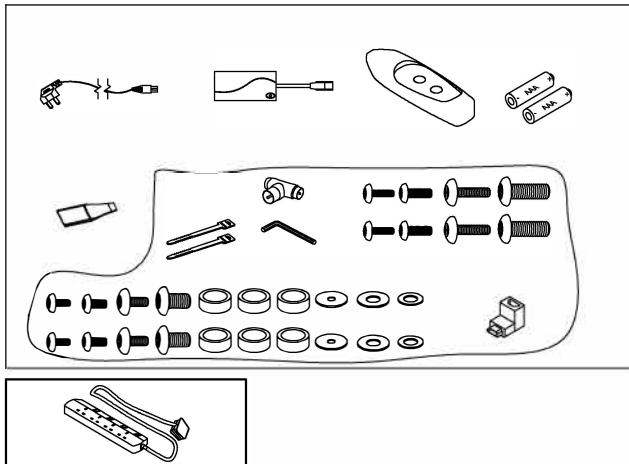

YOUR TELEVISION REAR VIEW
HDMI CABLE PLUG POSITION POSSIBLE SCENARIO'S

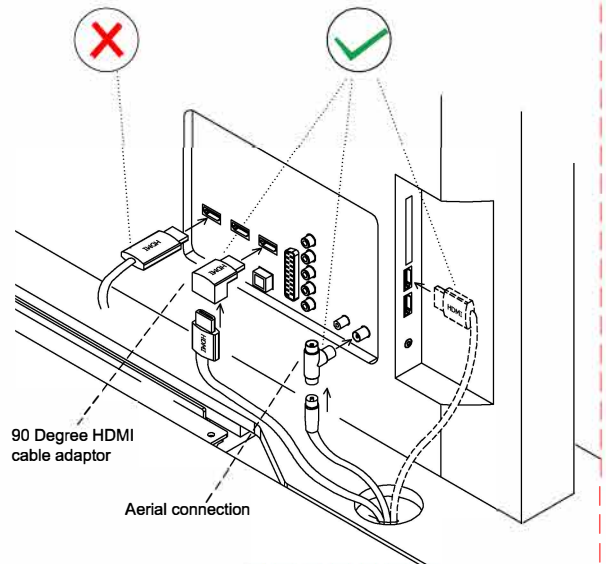

Attention Please Note : Connecting Your HDMI or Aerial Cable as shown in diagram (X) can seriously Damage Your TV sockets.

To reduce this possibility we have supplied 90 degree adaptors for both HDMI and Aerial connections.



This will reduce the cable protrusion and lessen the possibility of the cable colliding with the bed frame.

These can be found in the bed frame hardware pack located in Box 1 (foot end). Please refer to the diagram above for the correct fitting of cables. More detailed information can also be found on step 12 of your assembly instructions.

The manufacturer or retailer will not accept responsibility for any damages arising from incorrect installation.

ATTENTION! PLEASE NOTE:

In the event you are experiencing any technical difficulties and you require additional assistance/ support with your product 'Mechanical/ Electrical' function - Please contact:

SUPPORT EMAIL : support@bssbfurnitureinnovation.com

UK PRODUCT SUPPORT HOTLINE : 01462600064

Contact your retailer for all other issues such as damage, missing or faulty components (non electrical) or anything else of a non technical/electrical nature.

Step 3-1

- Carefully lift the foot end back to it's upright position.
- Loosen the bolts located in the foot end.
- Please note these should only be loosened and NOT removed.
- Hook the side rail brackets over the bolts on both sides.

Step 3-2

- Attach the Head End Panel "D" as shown.
- Loosen the bolts attach to the side rail as shown. (Note : only loosen the bolts do NOT remove them)
- Hook the head end panel over the bolts as shown.
- Repeat the action on the opposite side.
- Tighten all the bolts in side rail & head end panel. (Ensure all angles are at 90°)

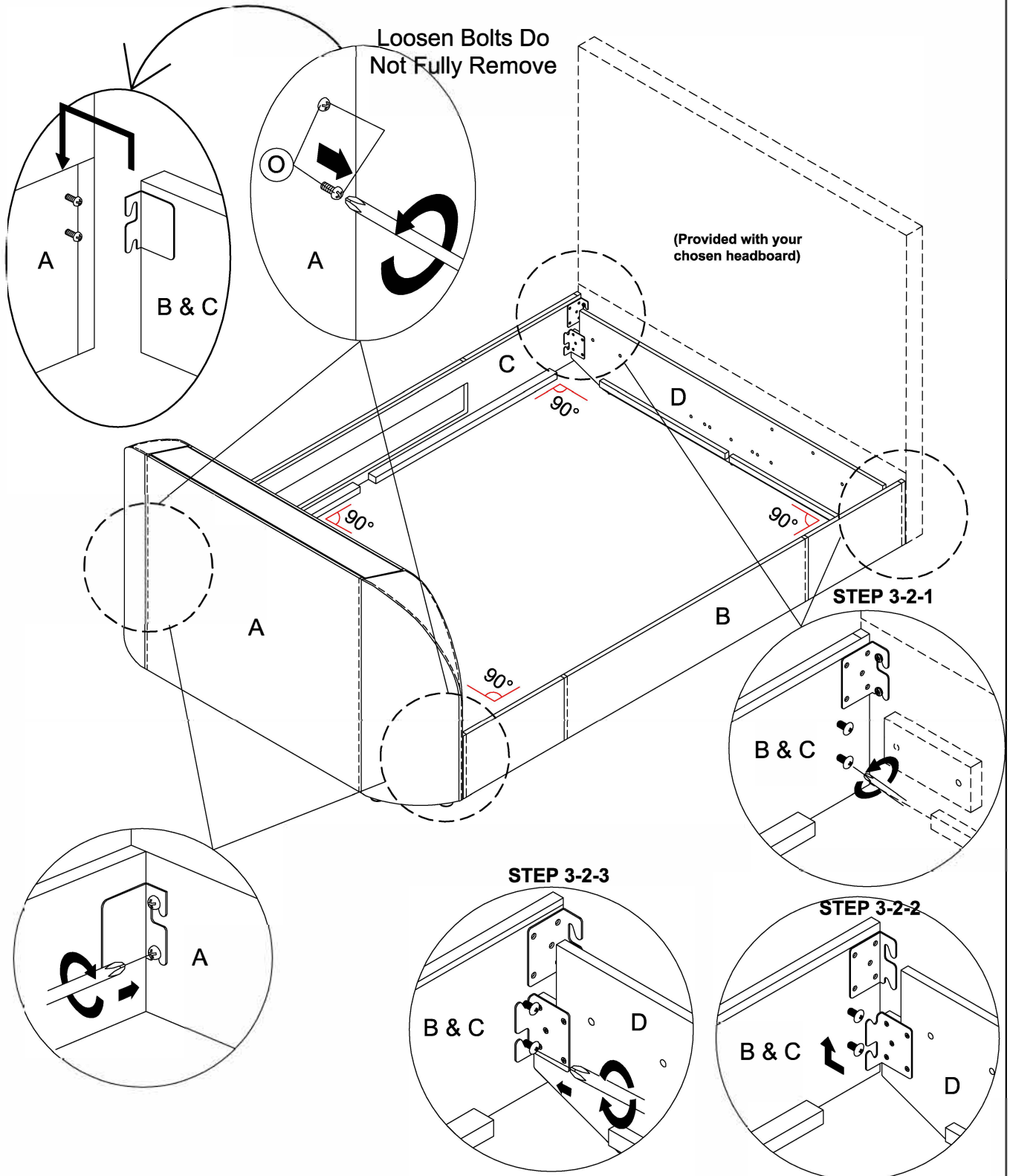

Step 4

- Attach the rubber stopper (AB) with bolt and washer (AC) to the foot end & head end panel using screwdriver (Y) provided as shown.
- The rubber stopper must be fixed to follow the lift base opening side as shown below.

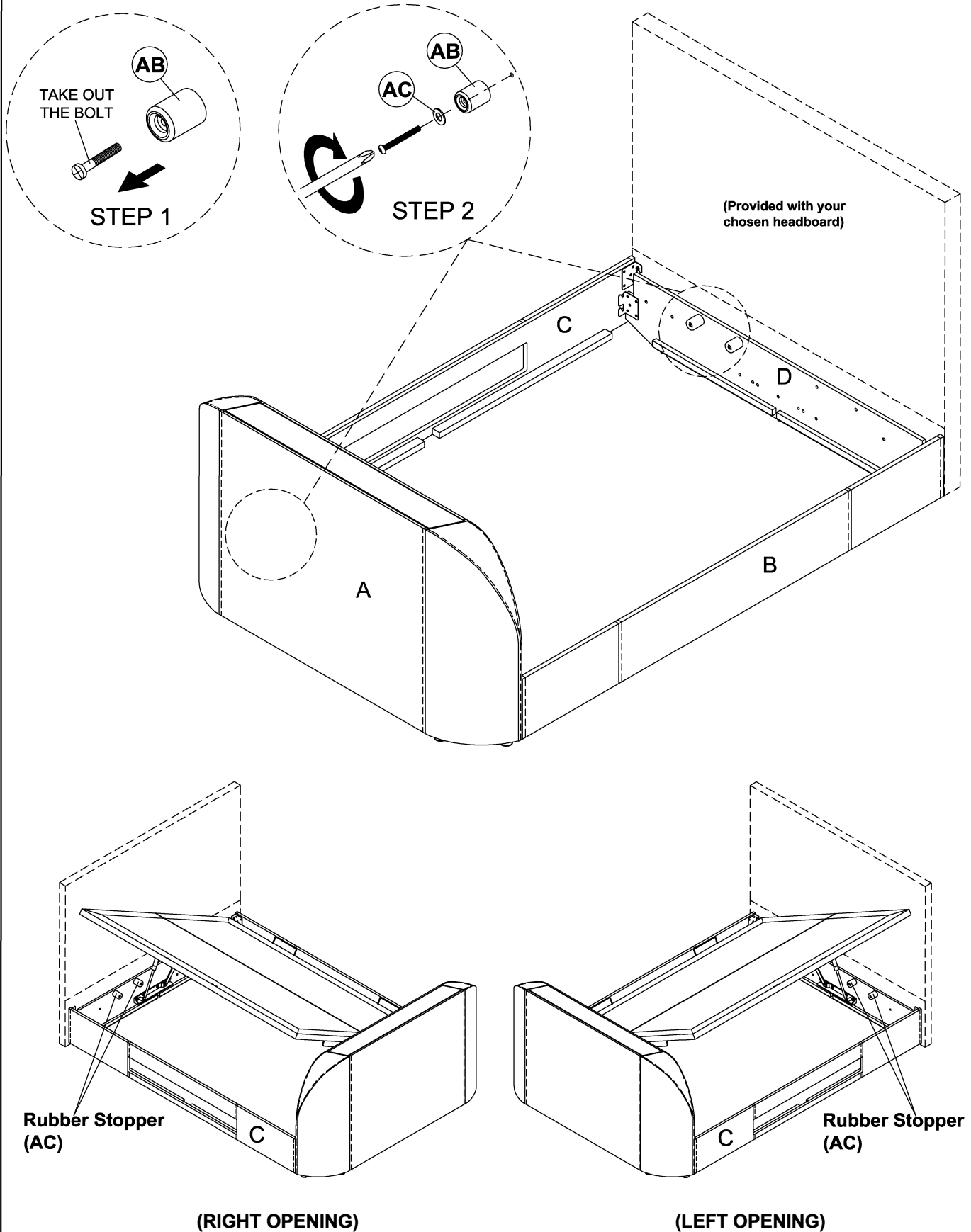

Step 5

- Installing Batteries in the TV mechanism Wireless Remote Control.

Battery:

Size: AAA - Ø10.5 X T44.5mm

Spec.: 1.5V

(AAA) Batteries x 2pcs (provided) install to battery case.

Caution: May explode or leak if recharged, inserted improperly, mixed with different battery types. Do not open battery. Dispose of used batteries promptly. Keep away from children.

Pull out the battery case from here to open

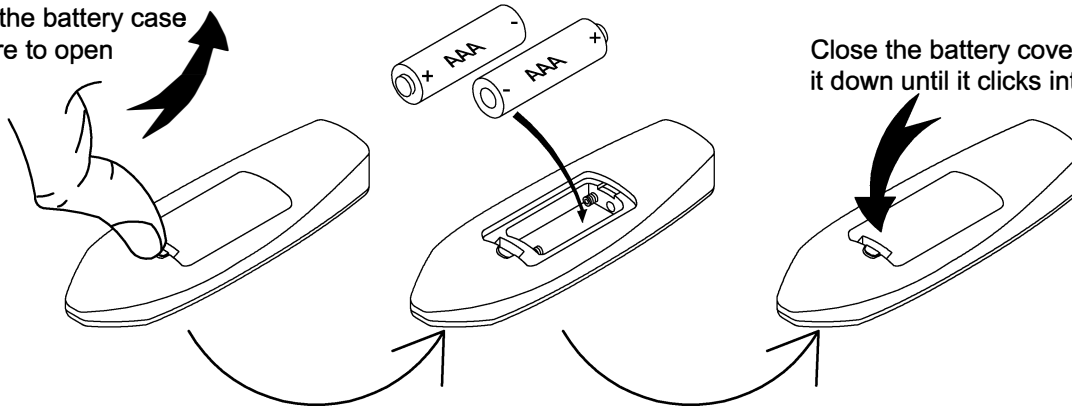

Close the battery cover and press it down until it clicks into place.

Step 6

- Connecting the TV mechanism cable as shown. It is essential that connecting to the power supply is done in this order. Failure to do so will result in damage to your product.

Step 6-1 Connect the Power Cable (13) to the TV mechanism adaptor (11), then plug the TV mechanism adaptor power plug into the TV mechanism receiver, which is pre-installed in the footboard, as shown.

Step 6-2 Connect the power cable (13) power plug into an 4 socket extension lead, then switch on.

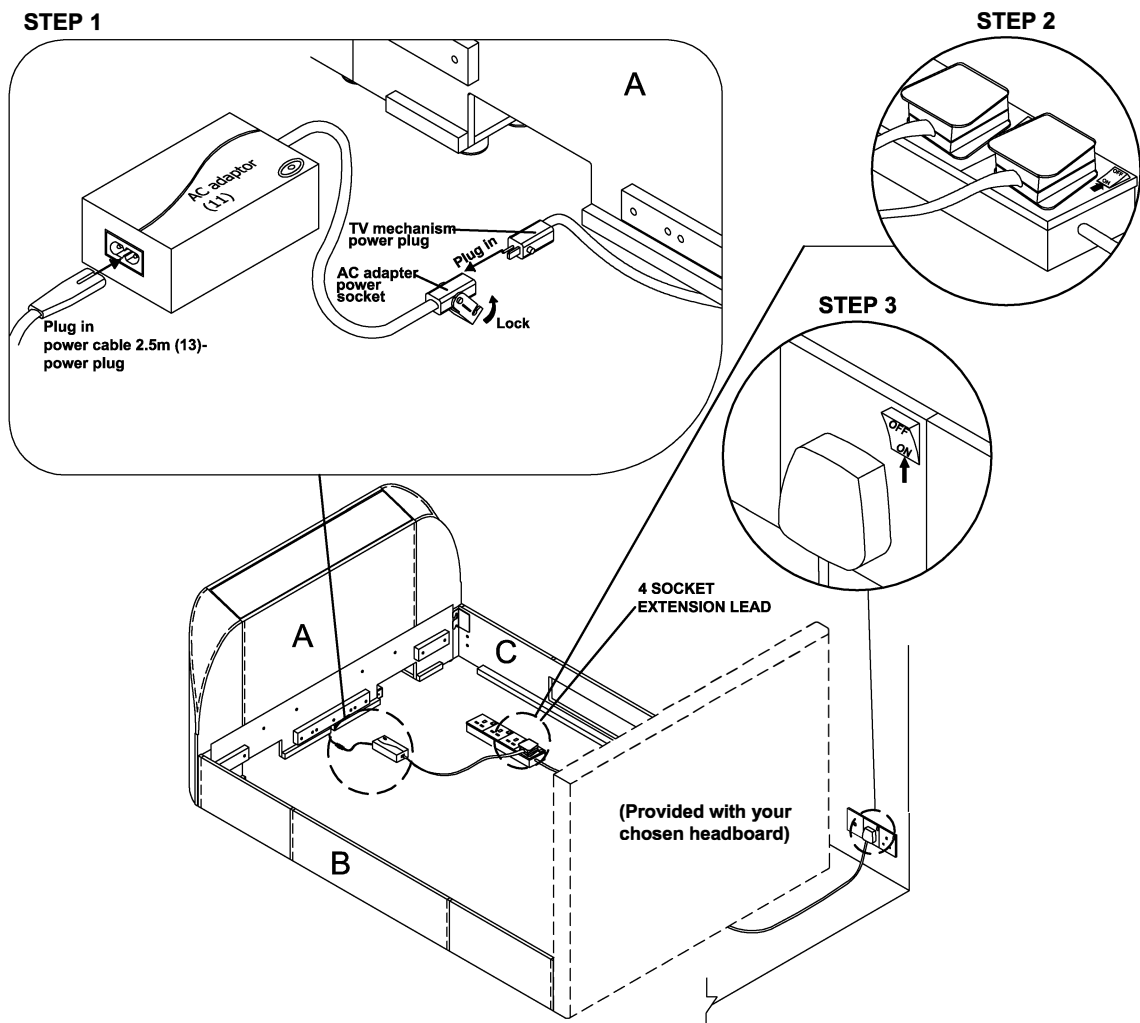

Step 7

- Continually press the "UP" switch on the wireless remote control, which will then lift the TV mechanism up until the footboard TV lid opens to its full extent. Continually press the "DOWN" switch on the wireless remote control to lower the TV mechanism.
- If the wireless remote control does not operate the TV lift mechanism, please follow the **SYNCHRONIZED SETTING** shown in below.

Wireless Remote Control

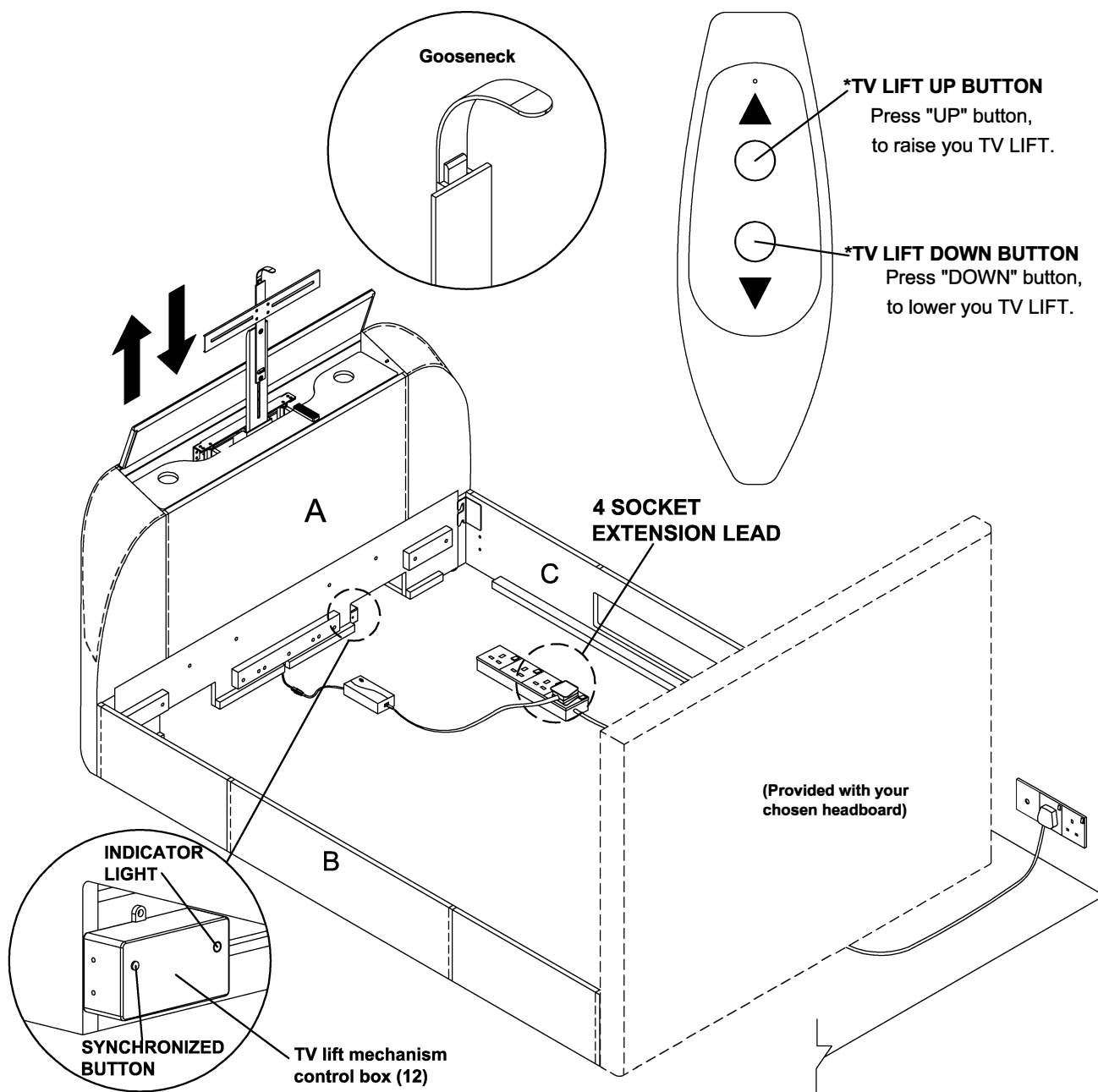

TV LIFT MECHANISM CONTROL BOX SYNCHRONIZATION

- Ensure there are two working batteries fitted correctly inside the remote control.
 - For initial start up, must synchronize the wireless remote control & control box.
- A) Press and hold the synchronization button on the TV lift control box located in the right hand mouse hole for 3 seconds, the indicator light will be flash red.
- B) Simultaneously, press together the up and down button on wireless remote control continuously for 3 seconds until the control box indicator light turn from the flash red to the long bright. This means the synchronization was success and can unclasp fingers from wireless remote control.
- C) Now the wireless remote control is ready to use.
- D) If the above step haven't been done within the 30 seconds, then the synchronization was not success and need to repeat the step again.

Repeat if necessary.....

In the event the remote control is not synchronizing with the TV Lift Mechanism.

Please contact UK Support: 01462 600 064

Step 8

- TV cable connection plan. Make sure you have all the relevant cable connections required (HDMI cable, TV Aerial cable, TV power cable, Optical cable etc...) before you install the TV.
- The cable management holes are provided in the TV Tray to help you manage the cable's to keep them tidy and free from snags. Pass all cables cleanly through these holes. While ensuring any cable slack is taken up from the bottom end of the footboard.

TIP:

Before fitting the TV, pass any cables through the cable management holes from the top to the bottom, while ensuring the cables slack is taken up from the bottom end of the footboard. choose the best side to use depending on where the connection ports are, on back of your TV.

All TV, HDMI, Aerial, optical cables MUST thread through the bungee cable located at both left hand and right hand side of footboard mouse holes. From a position looking at the TV screen.

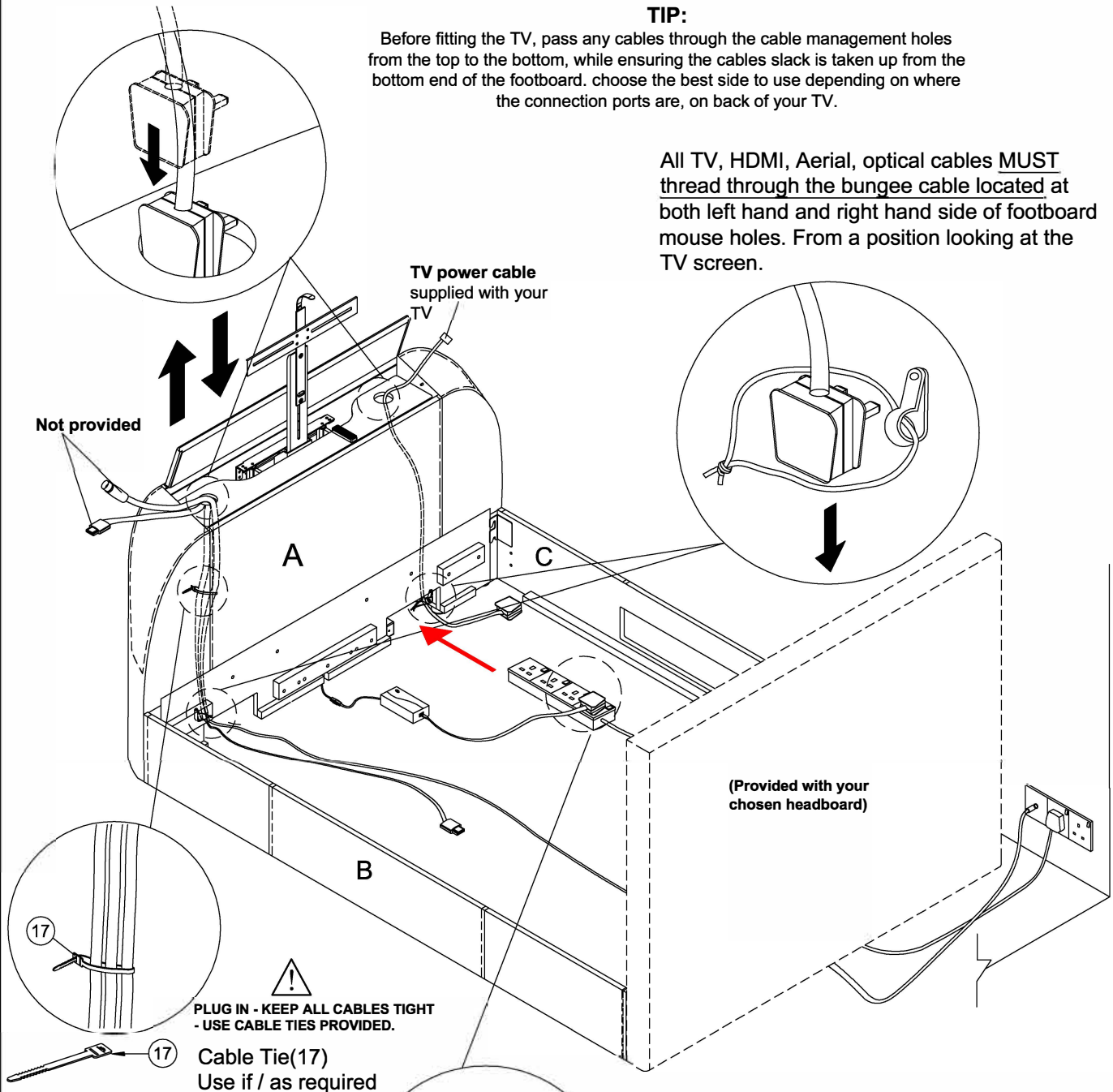

Insert the 4 socket extension lead to the footboard mouse hole.

Place all cables through the 'Cable Management' holes to prevent any damage to the cable when the TV Lift Mechanism is operating. Make sure all your the cables are long enough to let the TV Lift Mechanism move freely.

All the cables MUST be carefully pulled and fully extended.

Group the cables together as required below the TV Tray using cable tie(17) provided.

Step 9

- To adjust the TV tray to suit the height of your TV (without stand). Please follow step below
 - 9.1 : Measure and make a note of the height (without stand!).
 - 9.2 : Use the Allen key (20) to slightly loosen the up/down adjuster bolts-half turn only, do not remove all. (Please refer diagram below)
 - 9.3 : Slide "the TV vertical bar up/down, while using the measure line matching the noted measurement height of your TV. Then fully tighten the bolts.
 - 9.4 : When the TV is mounted it should sit neatly just beneath the lid opening Gooseneck.

Note: TV's lower than the minimum height of 440mm, are not compatible with the TV mounting bracket system.

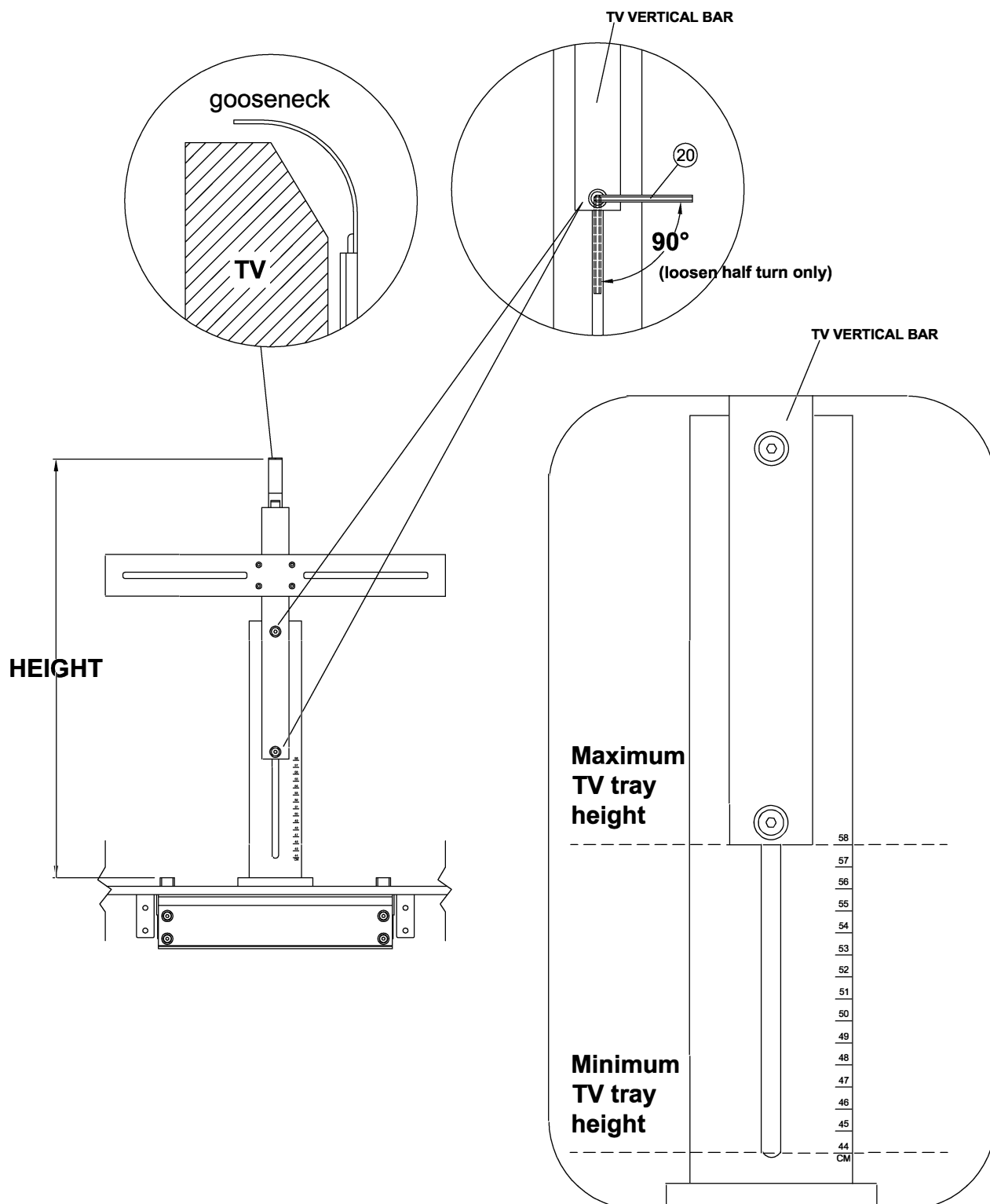

Step 10

- You are now ready to install your TV.
- Raise the mechanism to it's highest position.
- While standing behind your television (on the outside end of the footboard). - 'Facing the headboard'
- Carefully place the TV on top of the two rubber TV mounting pedestals - ensuring the Gooseneck arm is perfectly inline with the 'centre' of the TV.

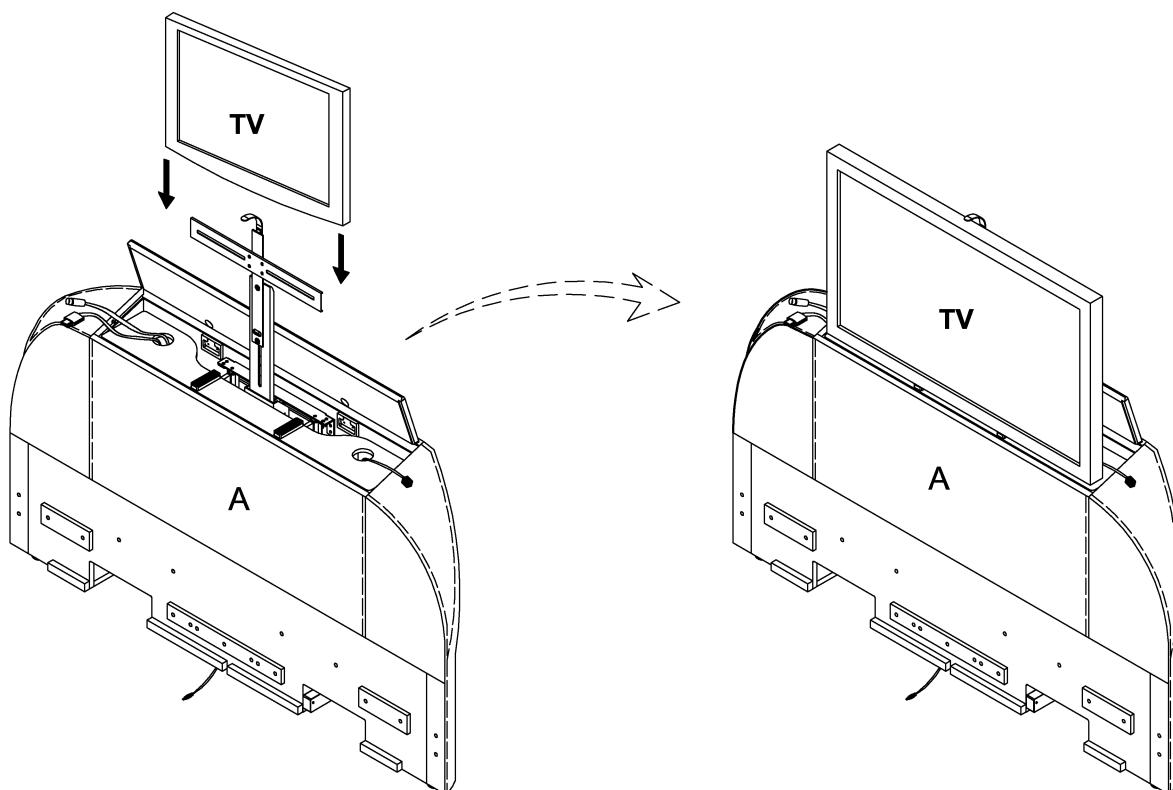

Step 11

- TV Flat Bracket (vesa bracket).

Please note : Item (21), (22), (23), (24), (29), (30), (31) or (32) TV fixing screws are compatible with most TV models. However sizes may differ depending on the TV model. If smaller or larger size screws are required these should be sourced from your local hardware store or TV specialist.

Washers may also be required. Your retailer may also supply alternative fixings depending on the TV model supplied at the time.

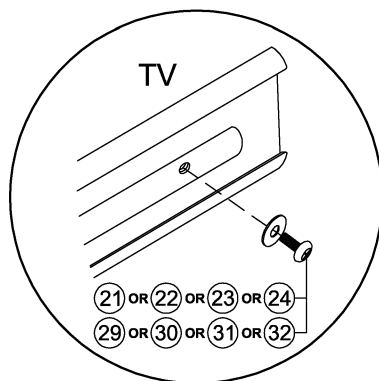
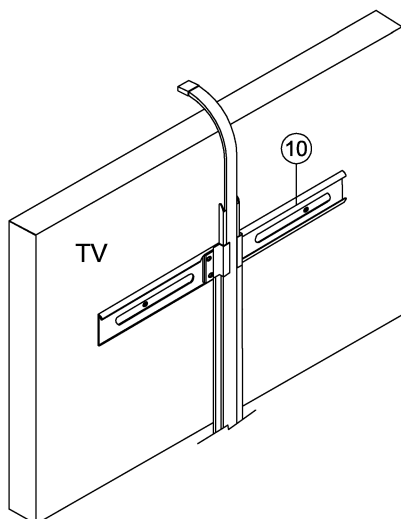

BOLT	(21)	(22)	(23)	(24)
BOLT	(29)	(30)	(31)	(32)
WITH				
WASHER	(25)	(25)	(26)	(27)

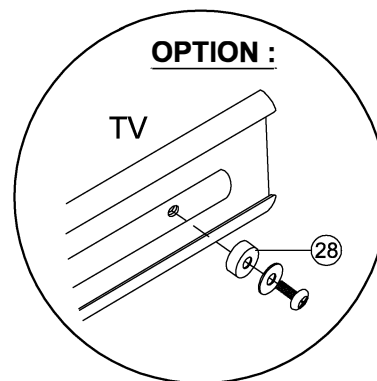

OPTION :
In the event you find the screws are too long for the TV with bracket please use Plastic collar (28) if required.

Step 12

- Connect all relevant cables to the TV.

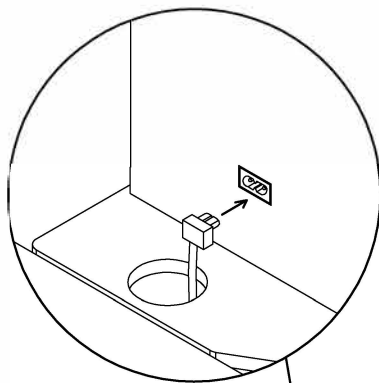

Note: For illustration purposes only, TV cables may vary.

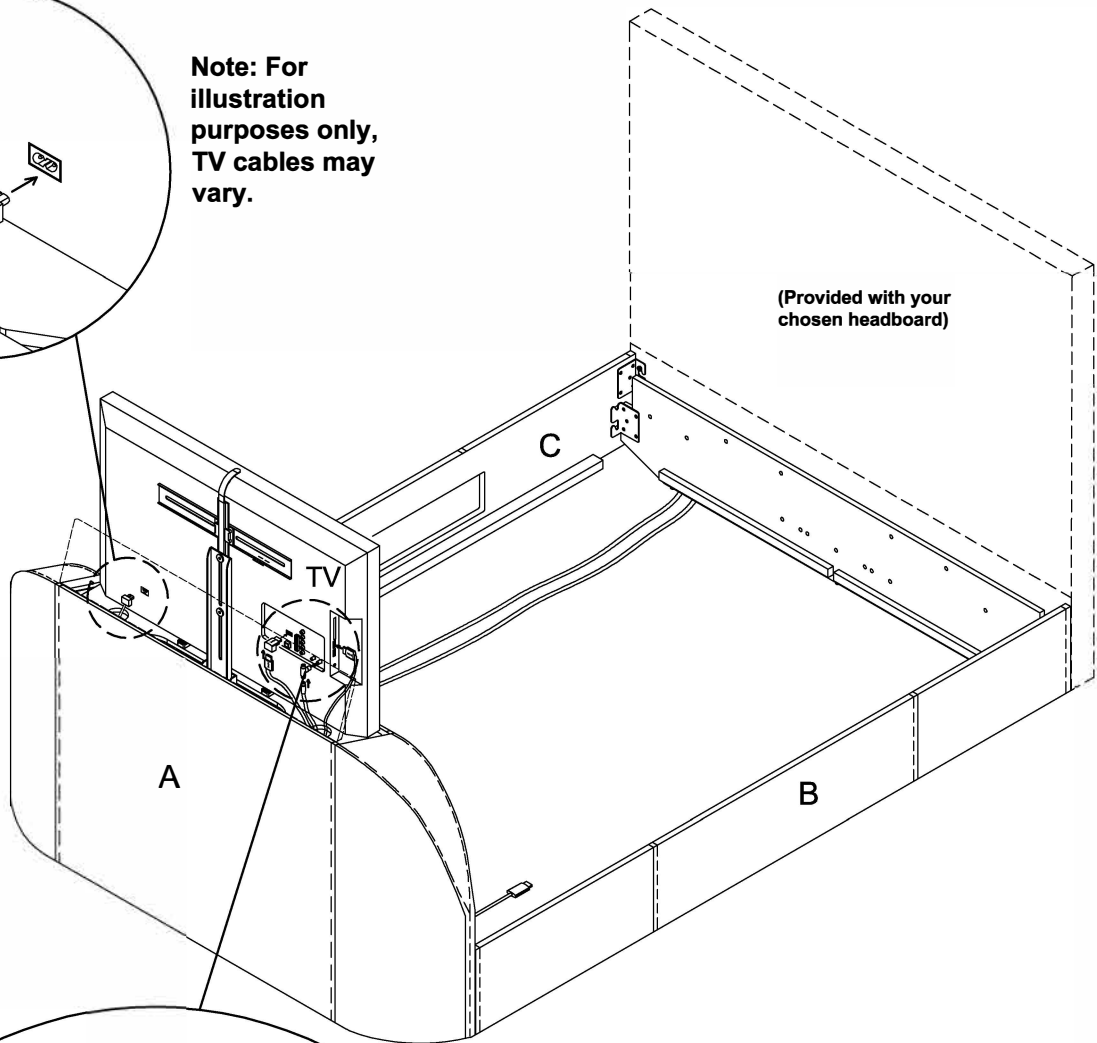

Note: For illustration purposes only, TV cables may vary.

YOUR TELEVISION REAR VIEW
HDMI CABLE PLUG POSITION POSSIBLE SCENARIO'S

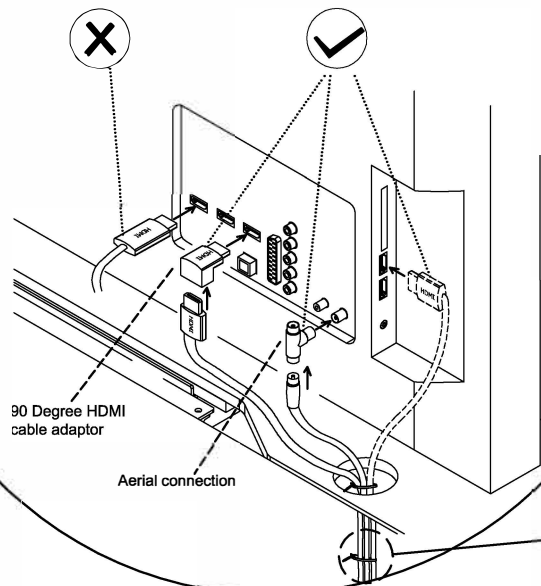

Attention Please Note : Connecting Your HDMI or Aerial Cable as shown in diagram (X) can seriously Damage Your TV sockets.

To reduce this possibility we have supplied 90 degree adaptors for both HDMI and Aerial connections.



This will reduce the cable protrusion and lessen the possibility of the cable colliding with the bed frame.

These can be found in the bed frame hardware pack located in Box 1 (foot end). Please refer to the above diagram for the correct fitting of cables. More detailed information can also be found on above diagram of your assembly instructions.

The manufacturer or retailer will not accept responsibility for any damages arising from incorrect installation.



17 Cable Tie(17)
Use if / as required

NOTE: The cable ports for televisions, DVD, TV aerial, Optical etc may not be the same as shown above and may vary depending on TV models.

Step 13

- Detail connection plan.

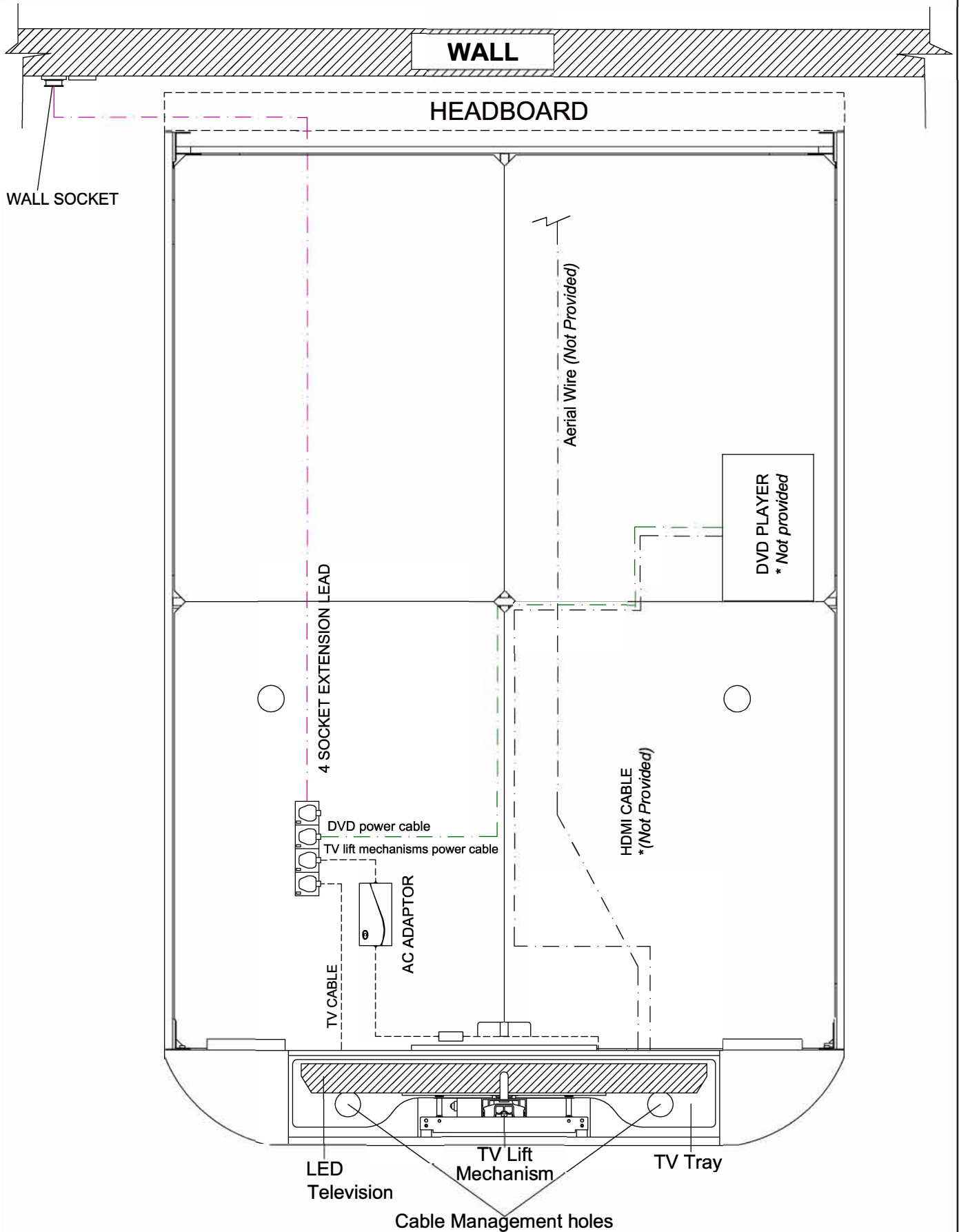

Note: Please ensure you thread the relevant TV connection cables through the provided holes in the TV Tray - please avoid crossing cables across the rear of the TV lift mechanism area.

HOLES DETAIL FOR FIXING LIFT UP MECHANISM

DOUBLE BED

**LEFT SIDE LIFT UP
FOR DOUBLE BED
(VIEW ON FOOT END)**

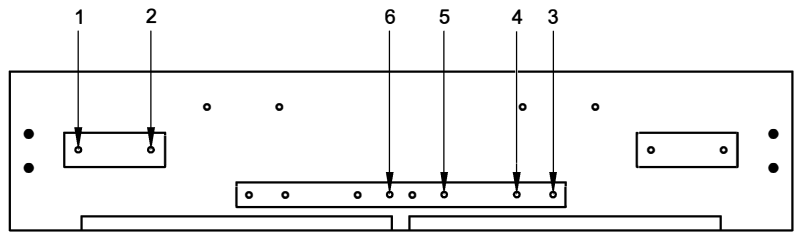

**RIGHT SIDE LIFT UP
FOR DOUBLE BED
(VIEW ON FOOT END)**

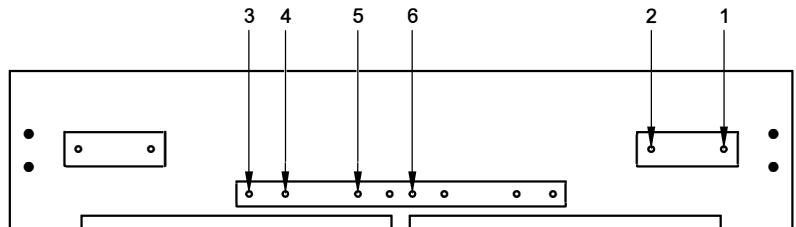

KING BED

**LEFT SIDE LIFT UP
FOR KING BED
(VIEW ON FOOT END)**

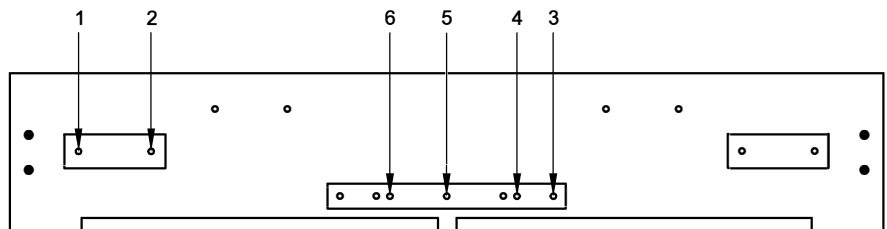

**RIGHT SIDE LIFT UP
FOR KING BED
(VIEW ON FOOT END)**

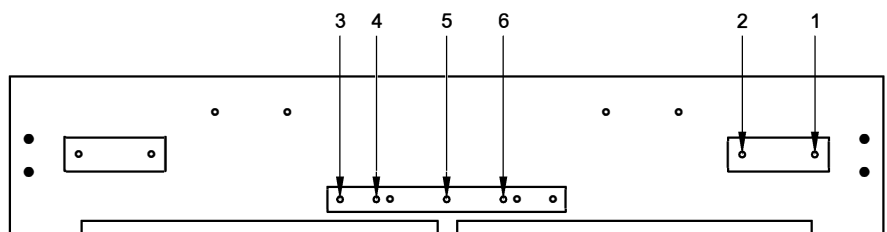

SUPER KING BED

**LEFT SIDE LIFT UP
FOR SUPER KING BED
(VIEW ON FOOT END)**

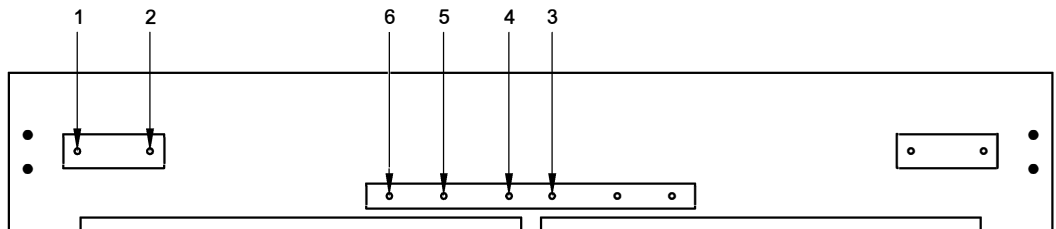

**RIGHT SIDE LIFT UP
FOR SUPER KING BED
(VIEW ON FOOT END)**

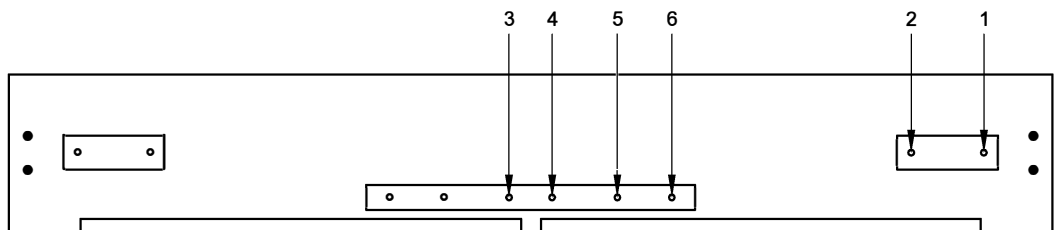

Step 14

- Take out the bolt and washer from head and foot ends.
- Attach the lift up mechanism using the bolt and washer.

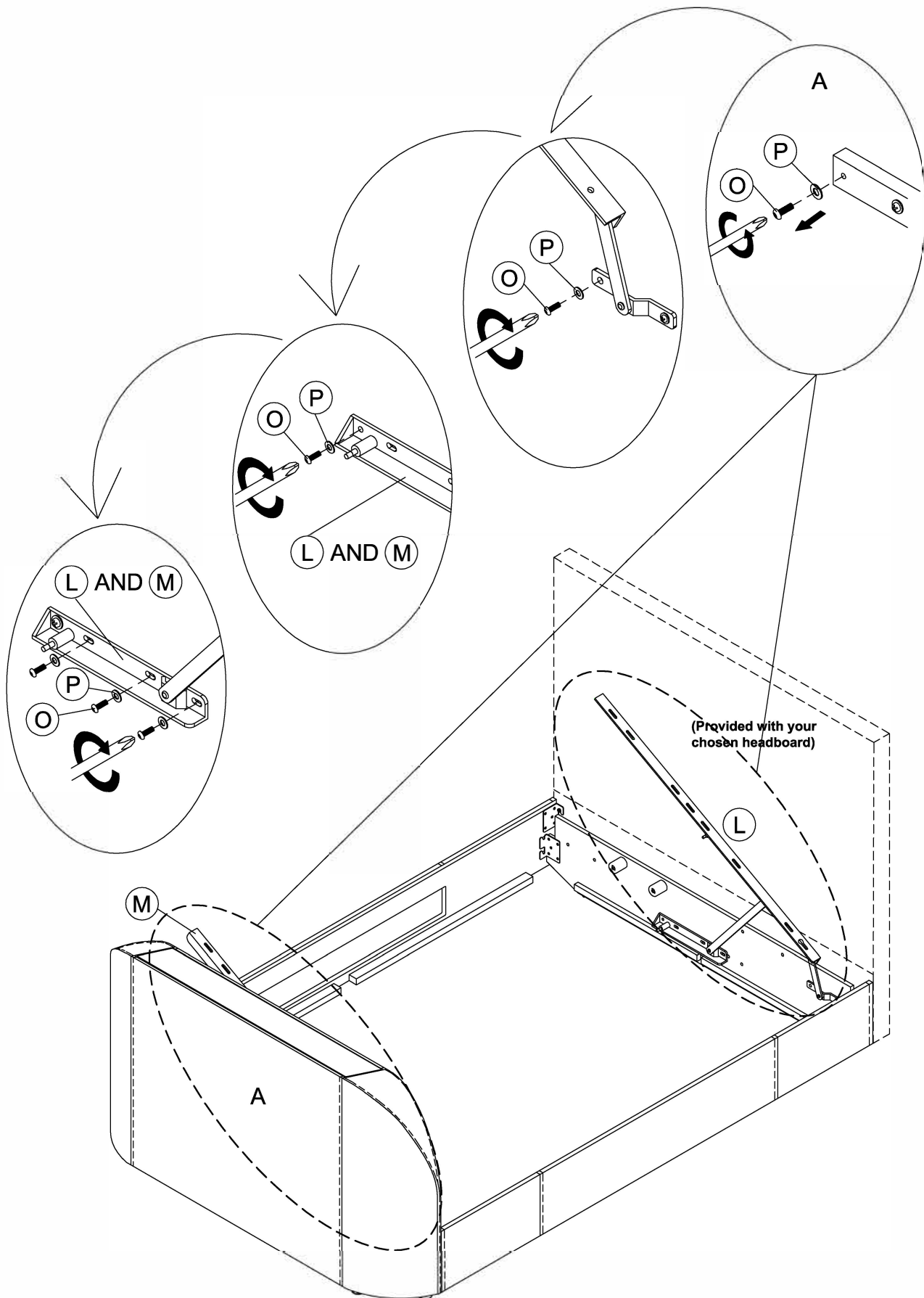

Step 15

- Attach the gas spring to the lift up mechanism using the nylon nut.

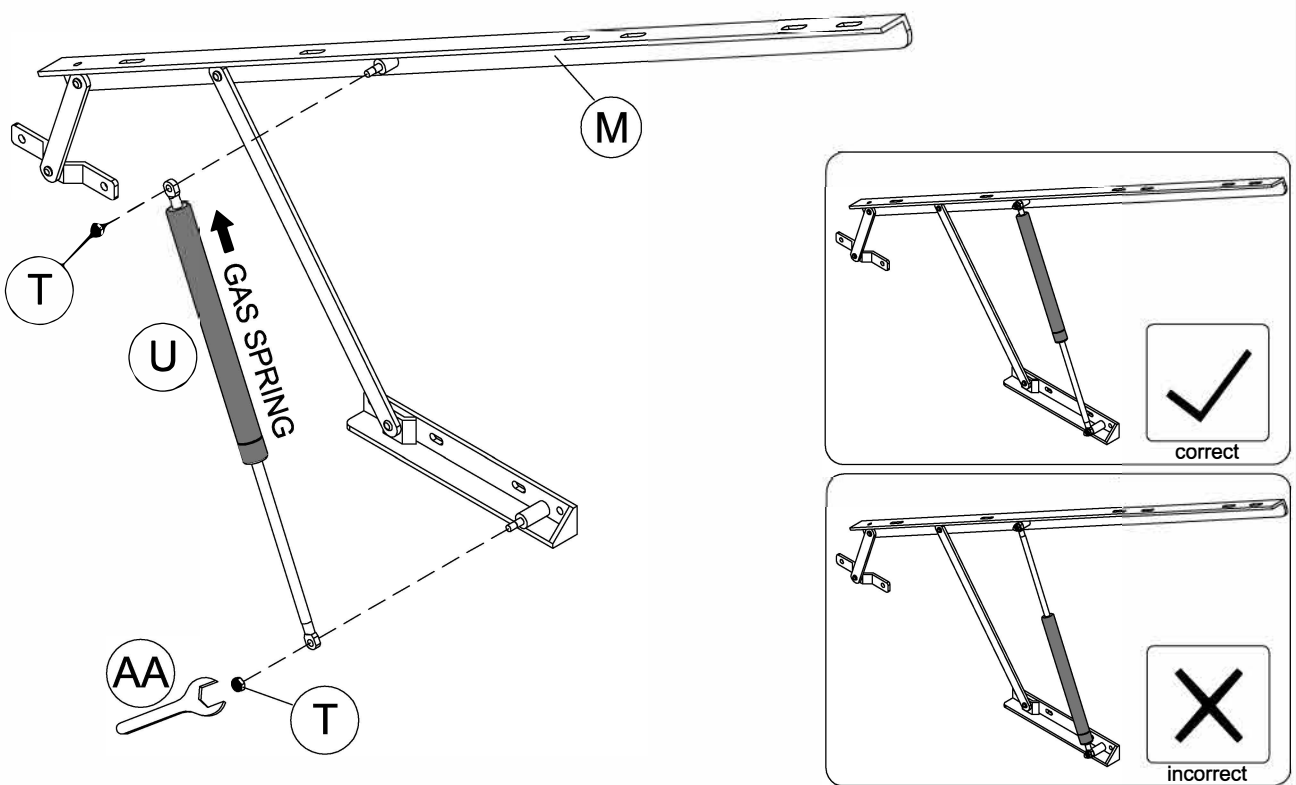
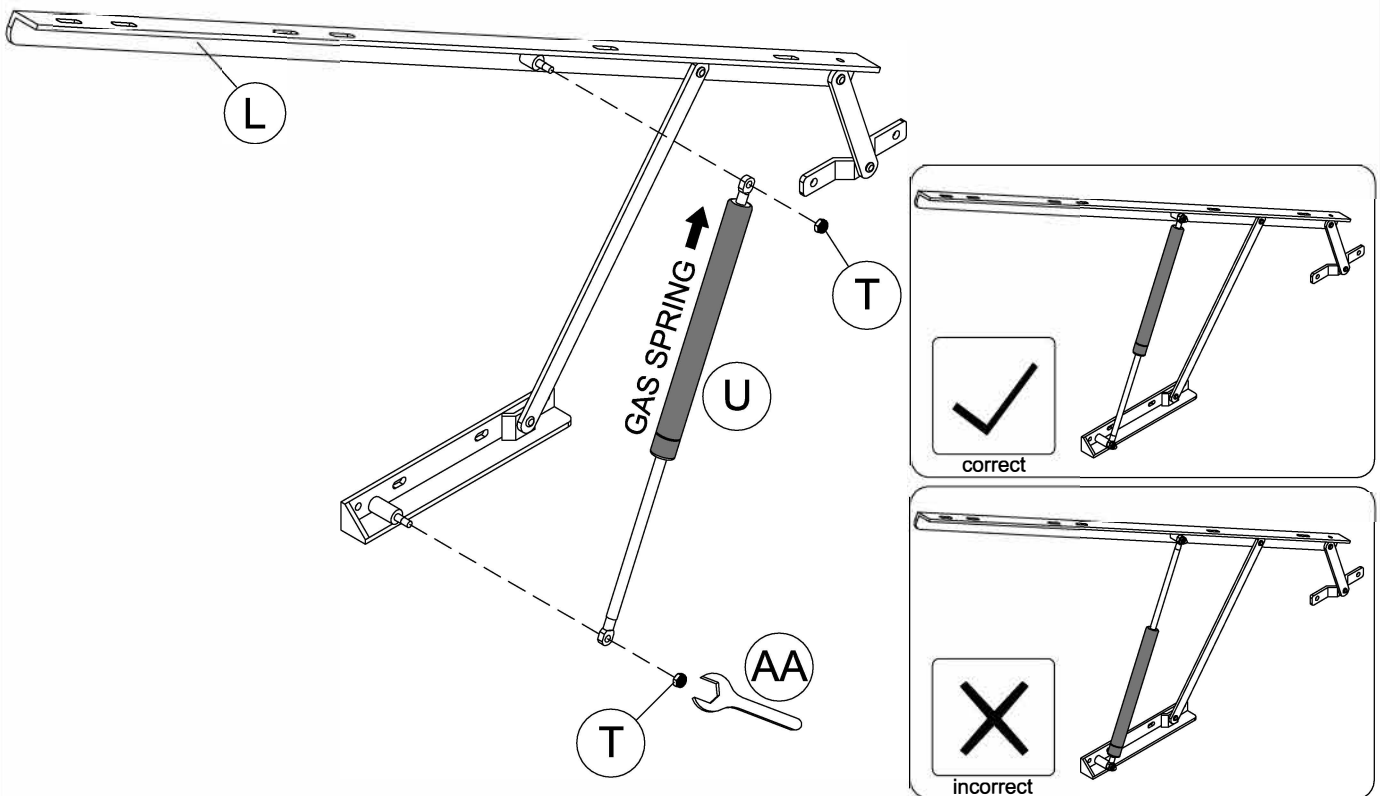

FULLY TIGHTEN ALL NUTS AFTER ATTACHING THE PISTONS.

Step 16

- Take out the all the screw and washer from lift base (J) as shown.
- For lift base (K), the last screw should be extend out 10mm as shown. The rest of screws & washers need to take out.

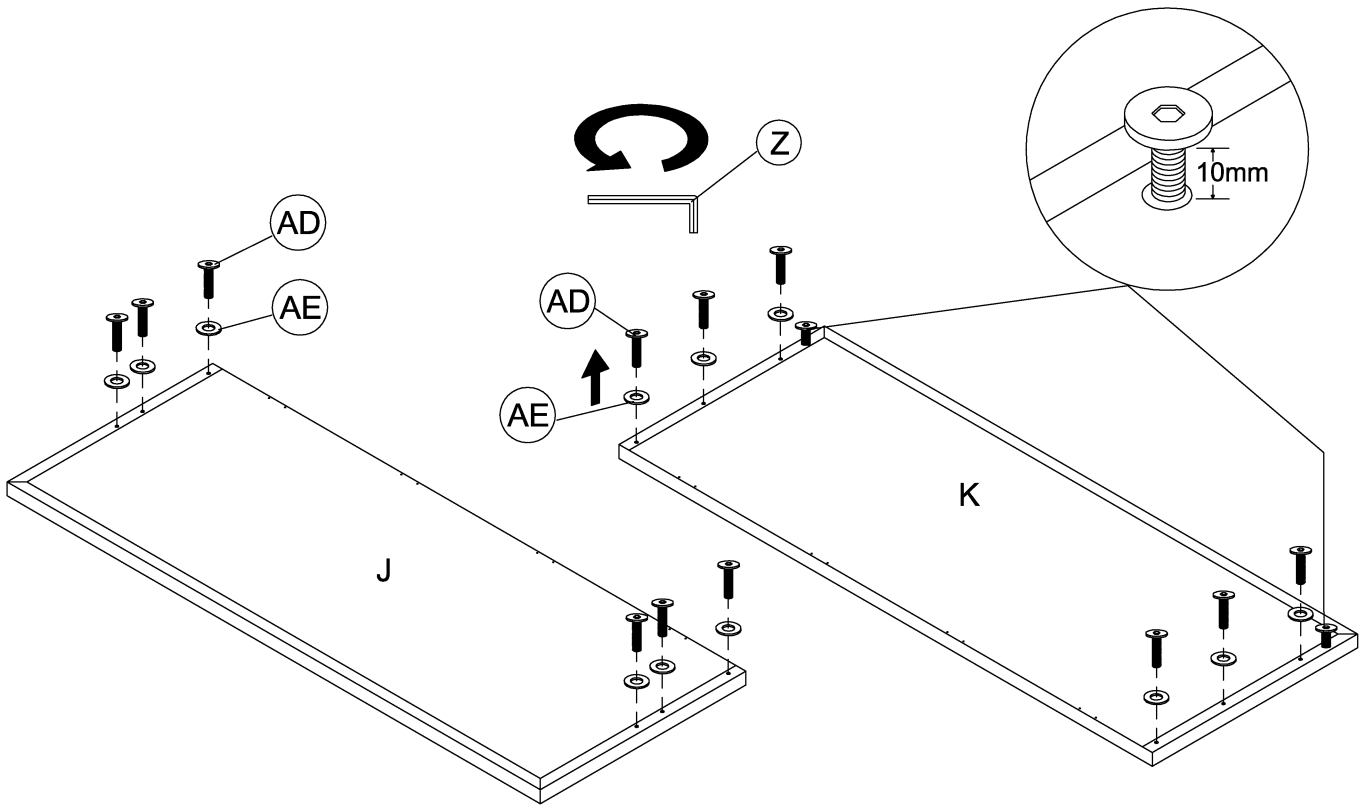

Step 17

- Attach the handle to lift base (K) with screw (V) and washer (W).
- Attach the mattress stopper (X) to list base (K) .

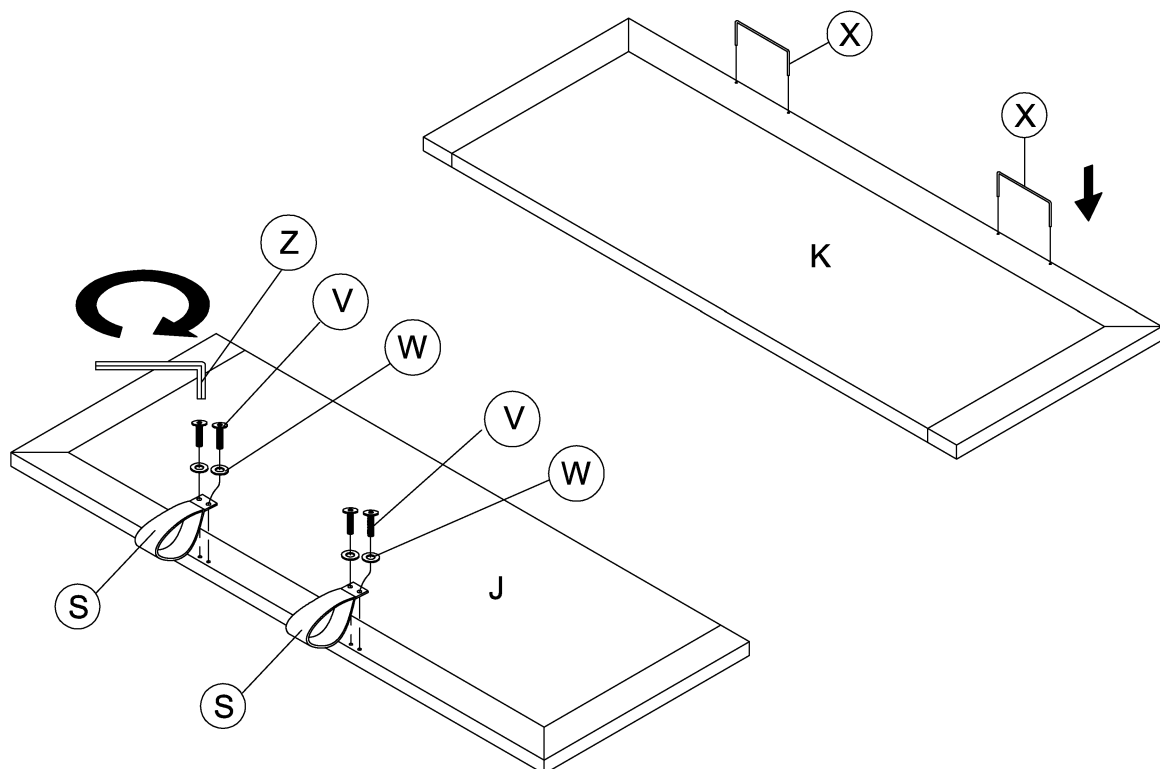

Step 18

- First put the back lift base 'K' on top of lift up mechanism 'L' and 'M' with the provided Screws (AD) pre-installed as per step 16 to the first hole for safety and to prevent the lift base from dropping down.
- Use the removed bolts and flat washers on step 16 to fix the back lift base 'K' with lift up mechanism 'L' and 'M' as shown.
- Use Allen key 'Z' fully tighten all the bolts as shown.

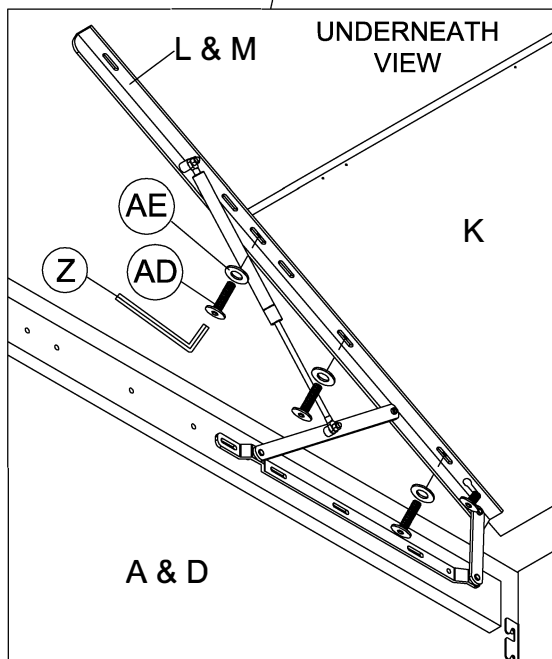
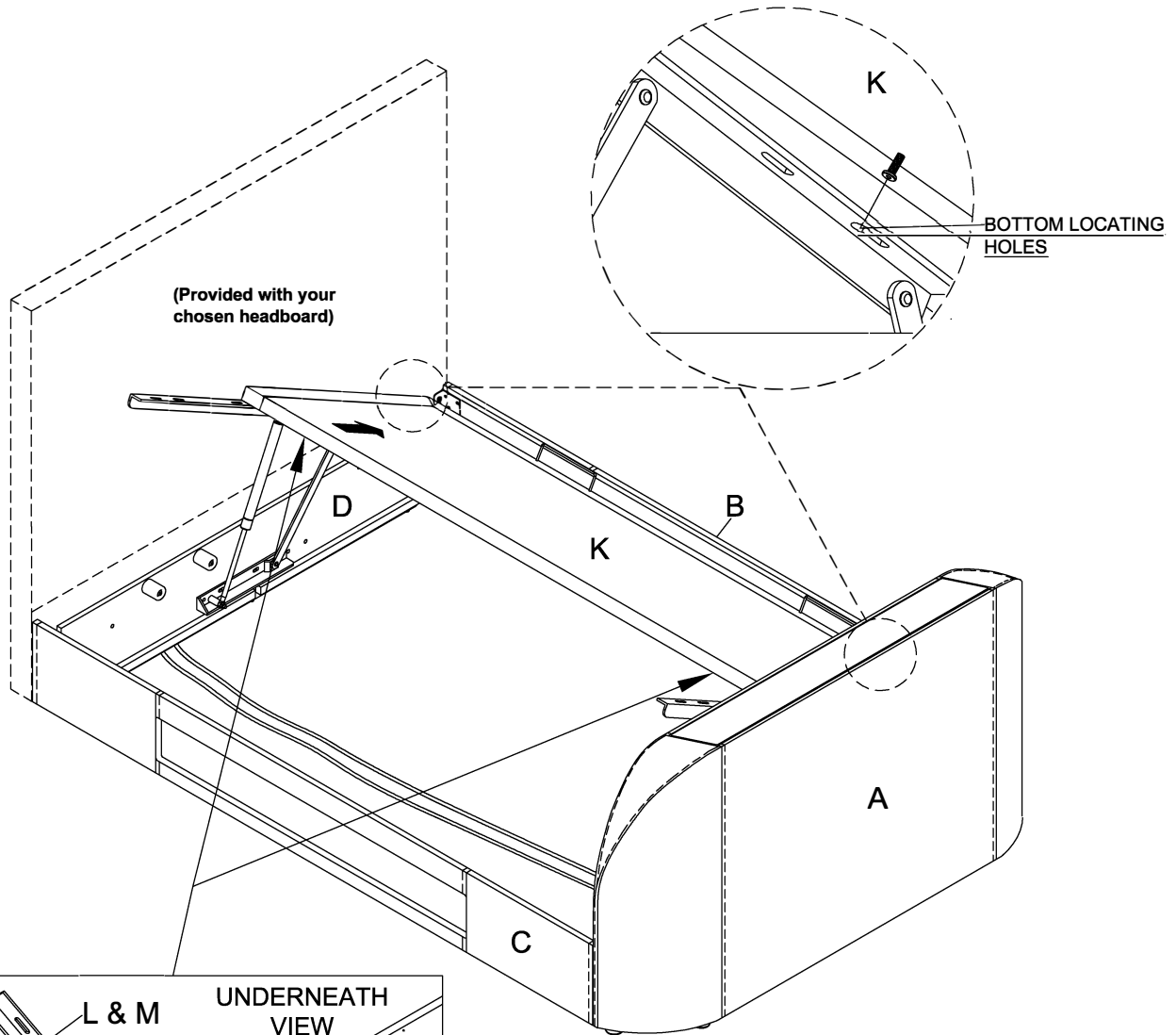

Step 19

- Attach the bottom cross rail (long) (E) & bottom cross rail (short) (F) to the headboard, footboard and side rail as shown. Being carefull not to catch the fabric.
- Attach the bottom cross rail (long) (E) to the side rail (B & C) and the bottom cross rail (short) X2 pcs (F) to the head end panel (D) and footboard (A) as shown (STEP 19.1),(STEP 19.2) & (STEP 19.3).

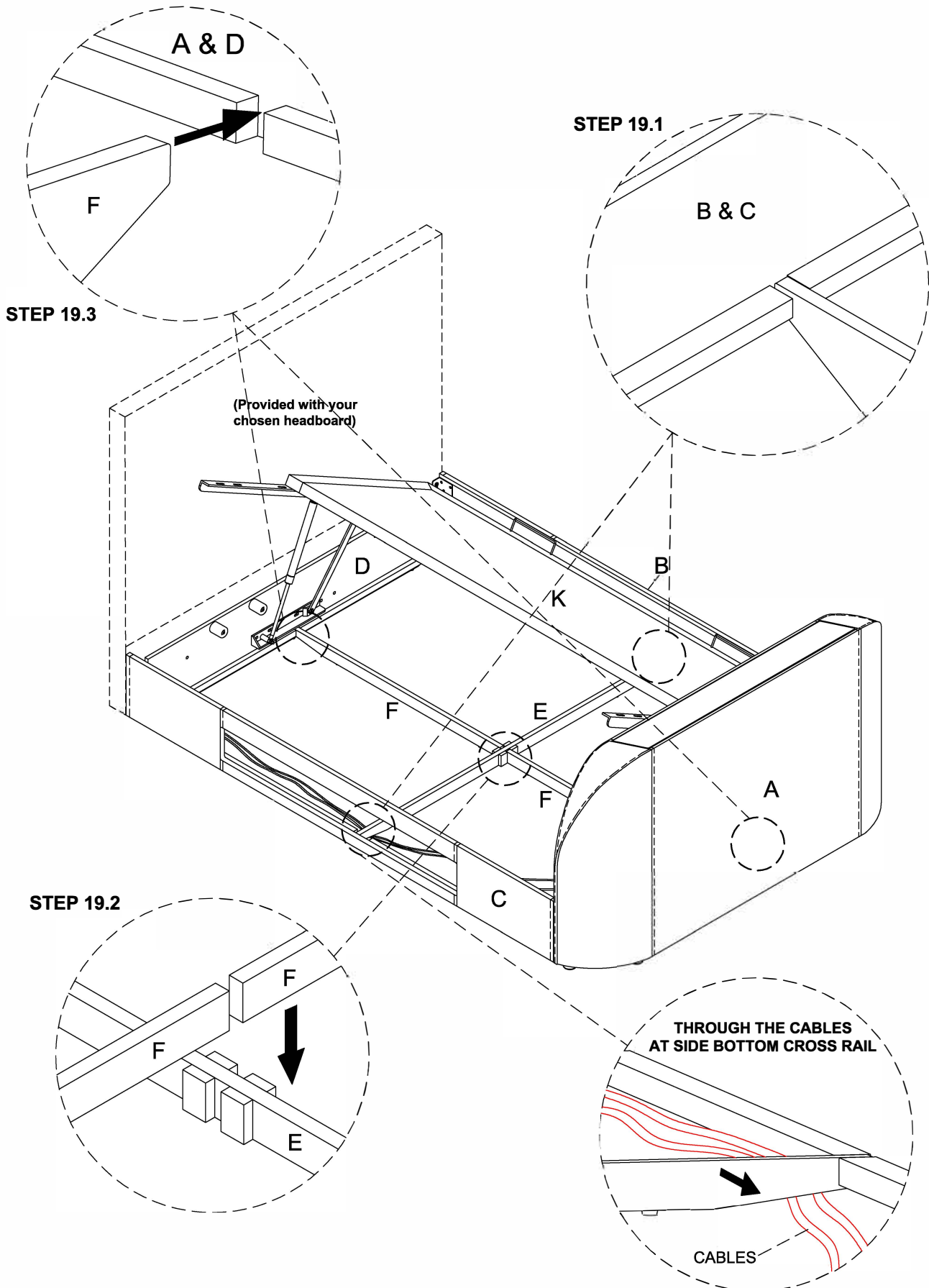

Step 20

- Place the base panel (G-1) & (I) on top of the bottom cross rail.
- Put the base panel (I) to the foot end as shown.
- Make sure the base panel with 90 degree angle was placed next to the side rail 'B'.
- Then carefully slide the base panel to fit the location.
- Diagram show the bed opening in left side.

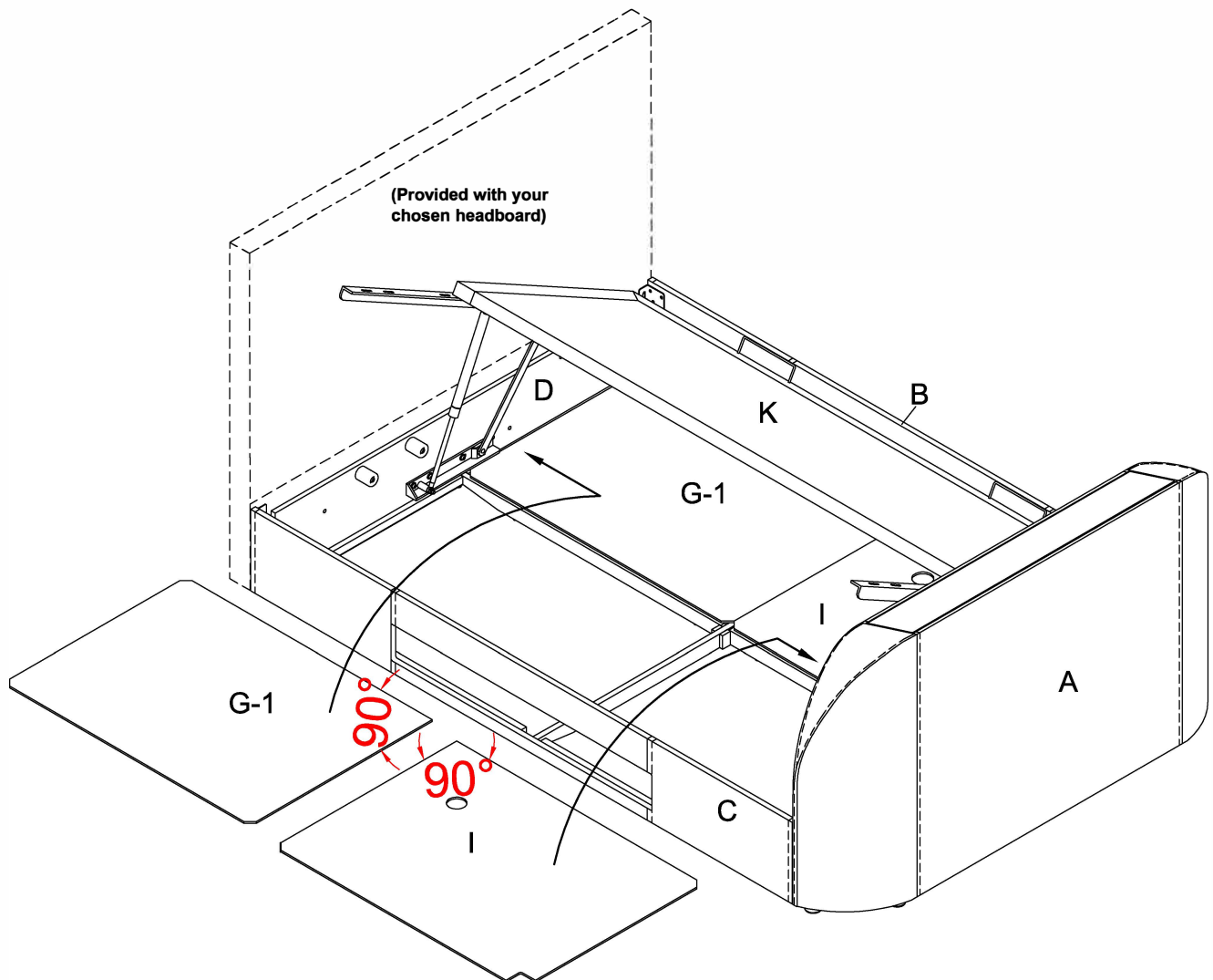

- **Optional-Right side lift up**

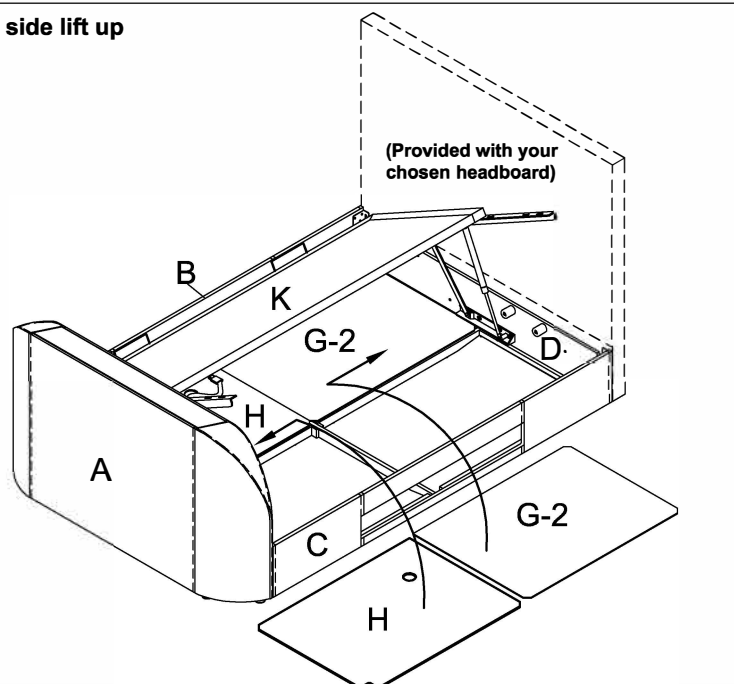

Step 21

- Attach the lift base (J) on lift up mechanism using screw and washer as shown.

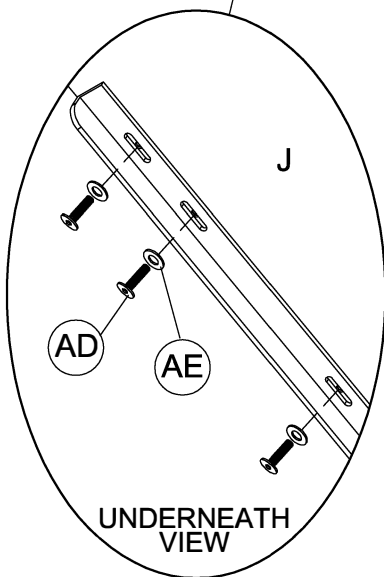
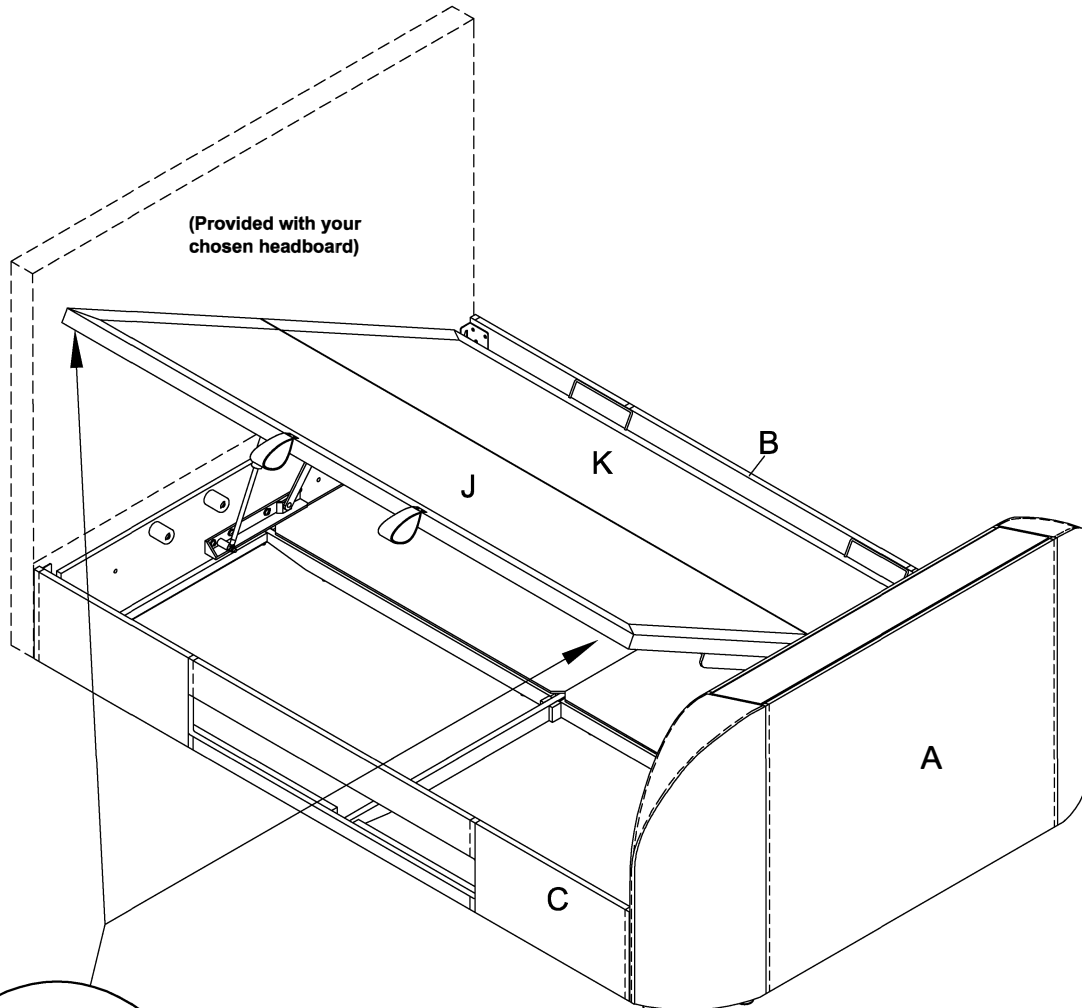

Step 22

- Attach the metal plate (R) to the bottom of lift base (J) & (K) with screw (Q) as shown.

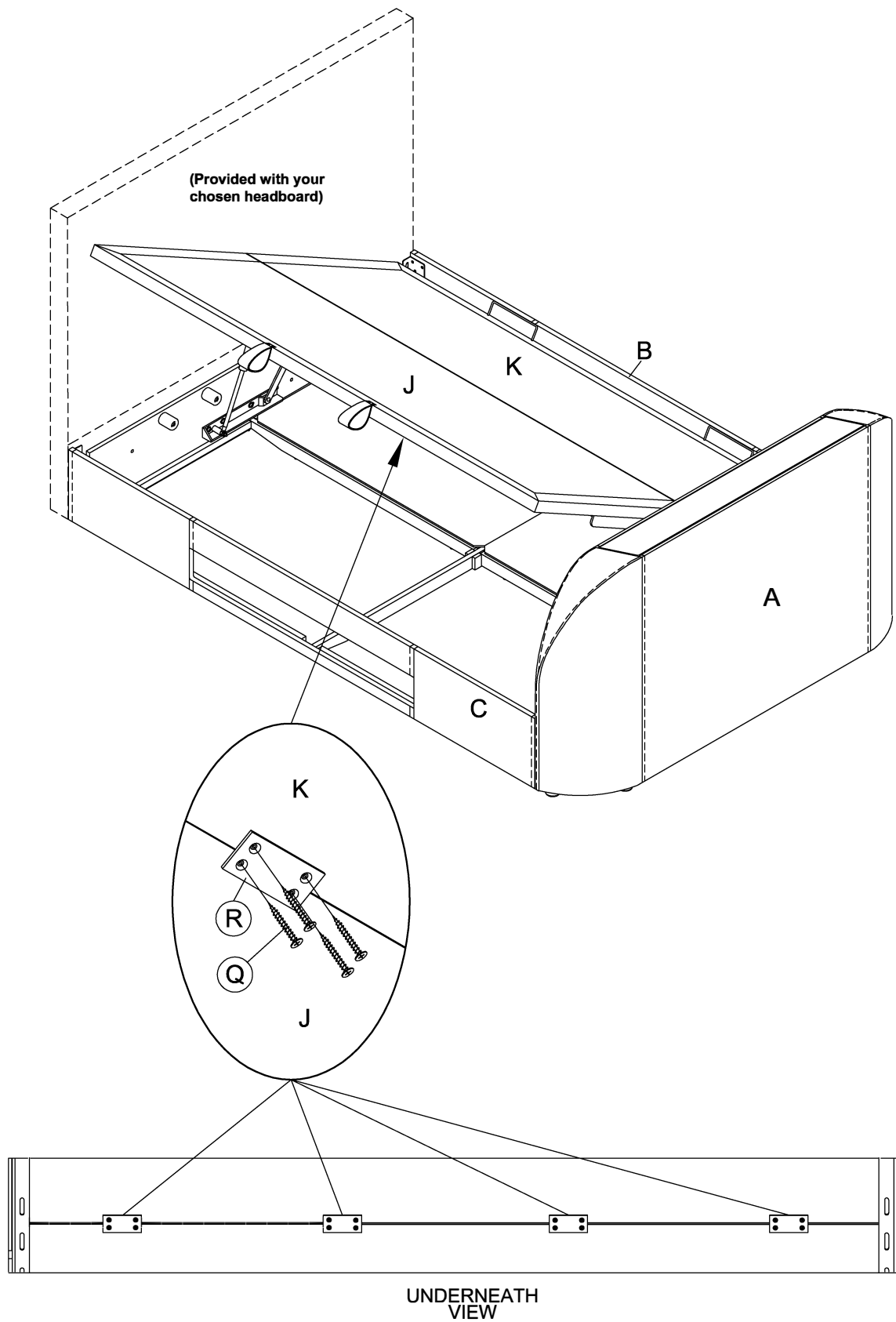

Step 23

- Place the base panel (G-2) & (H) on top of the bottom cross rail.
- Put the base panel (H) to the foot end as shown.
- Make sure the base panel with 90 degree angle was placed next to the side rail 'C'.
- Then carefully slide the base panel to fit the location.
- Diagram show the bed opening in left side.

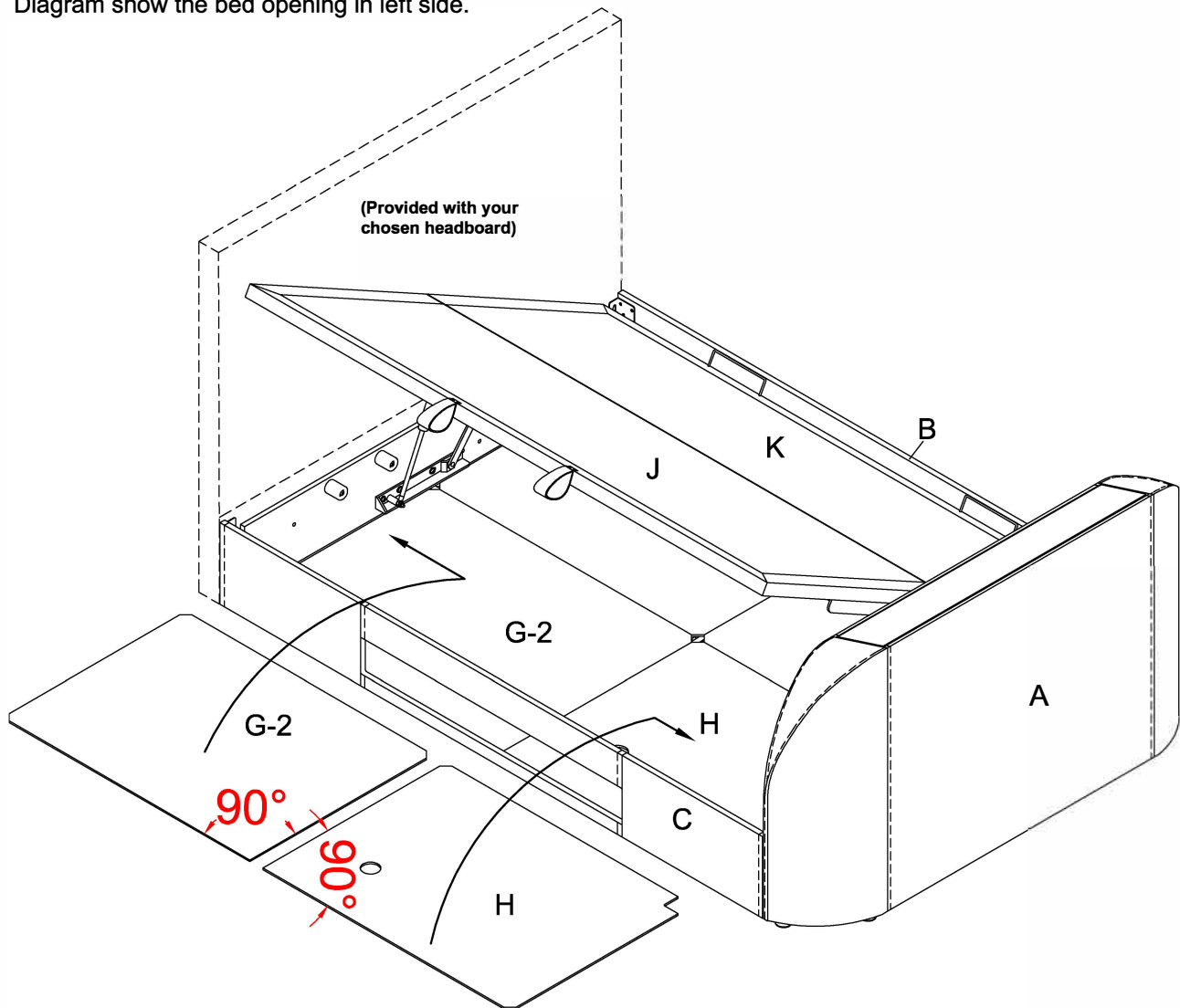

- **Optional-Right side lift up**

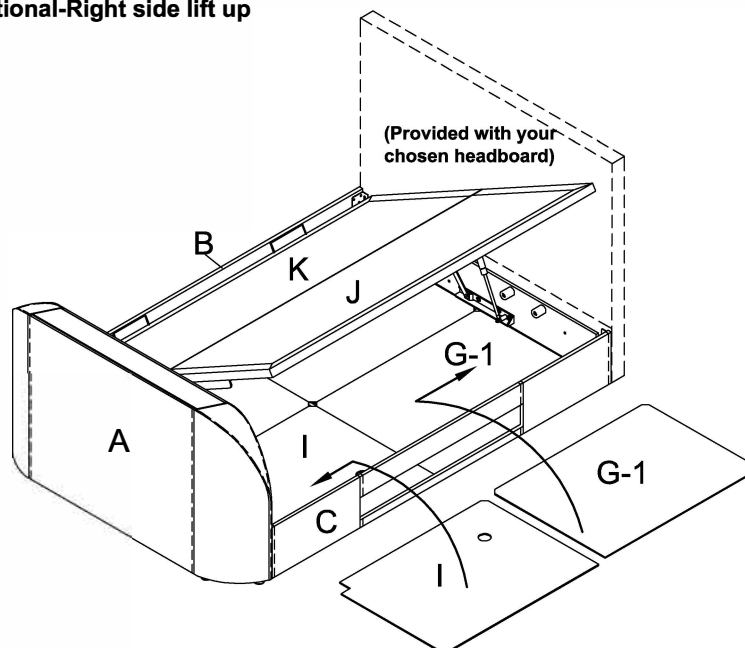

Step 24

- Attach the remote control pocket to the left or the right side rail as preferred.

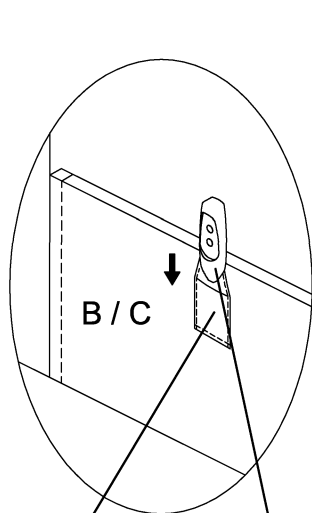
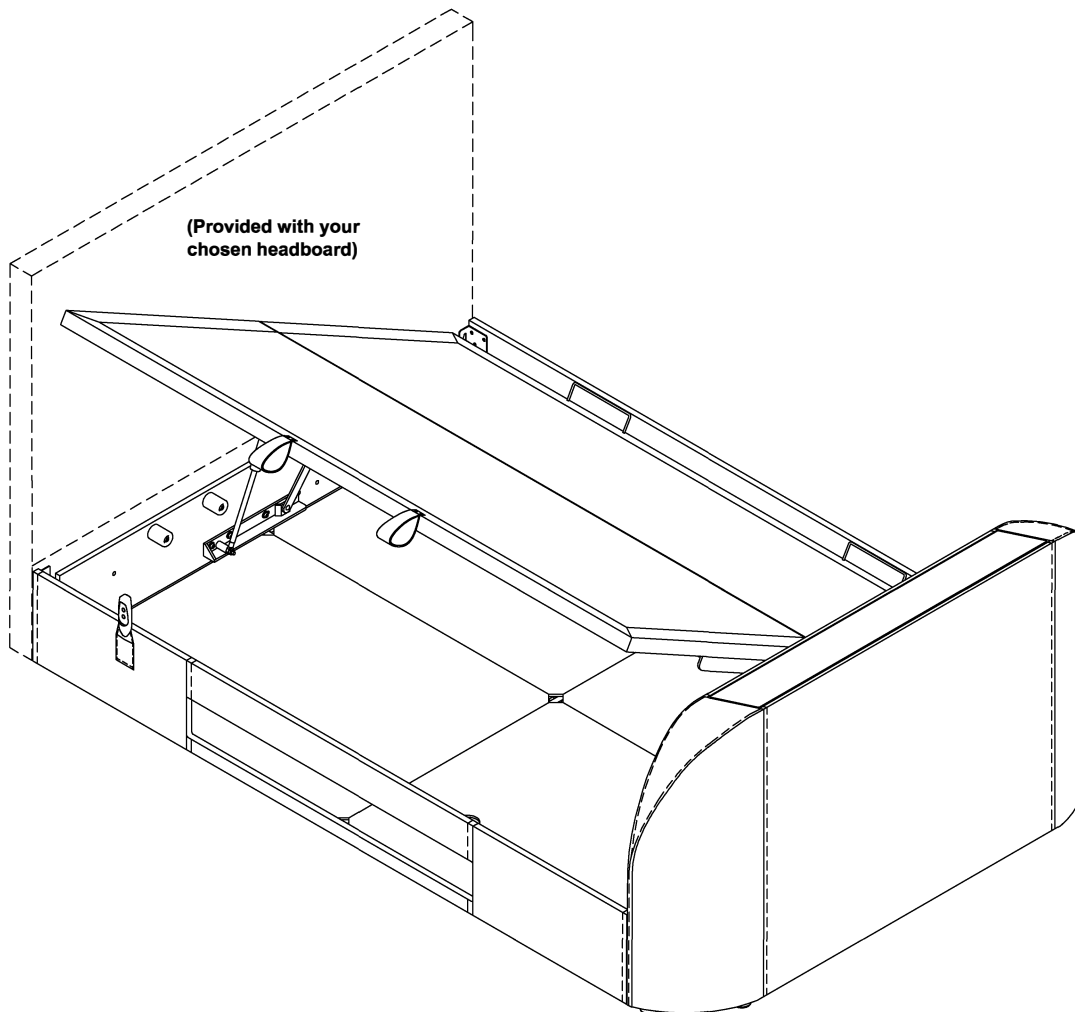

Remote
Control
Pocket

TV Mechanism
Wireless Remote
Control

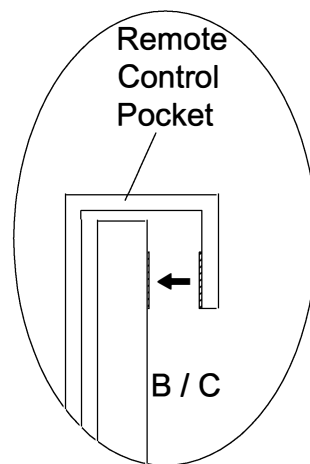

Step 25

- Attach the mattress before operating the lift base.

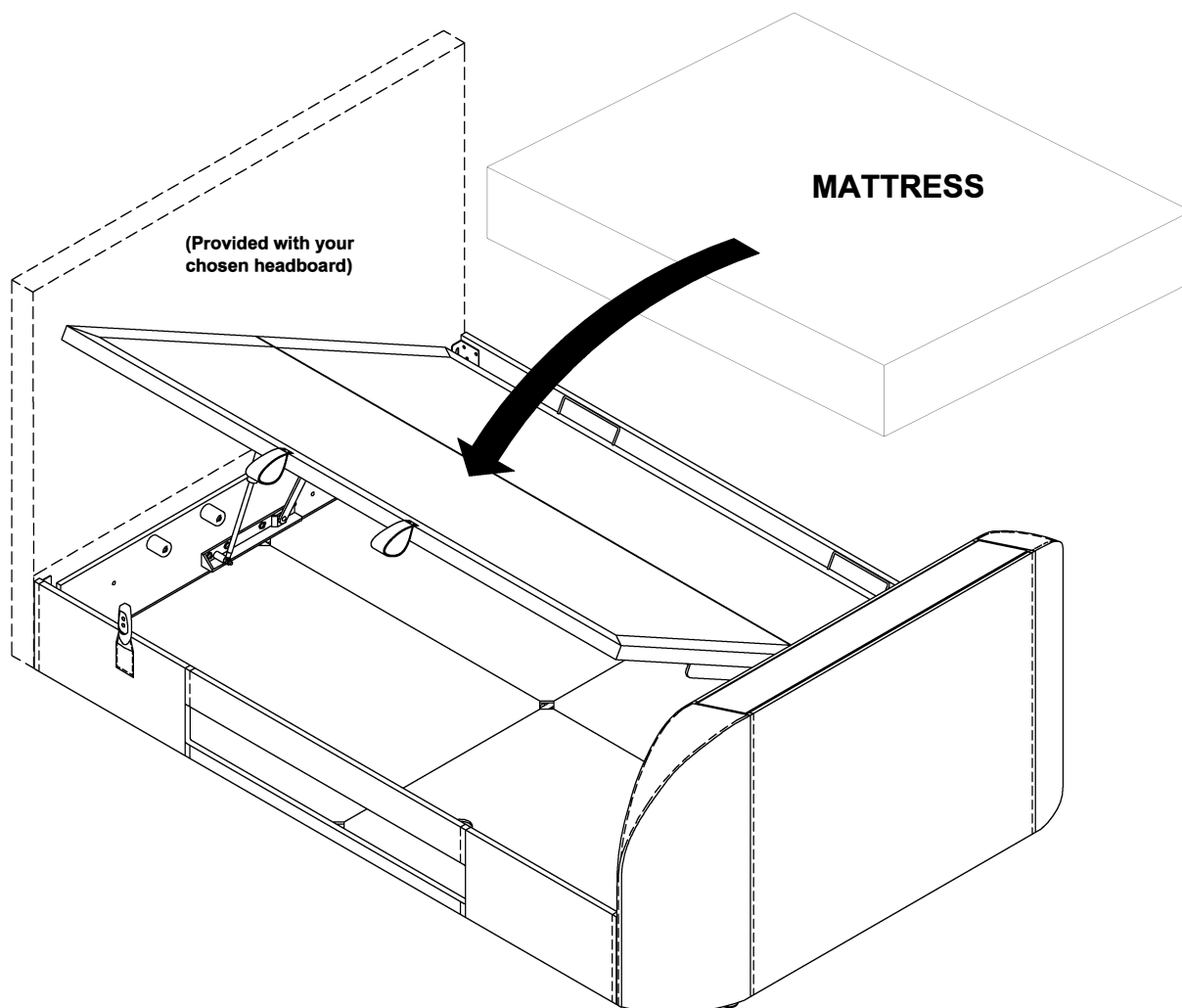

- A. This Lift Mechanism provides assistance with the lift of the mattress fitted to the base - it does not lift the mattress for you. The system has been designed to effectively lift the base system fitted with a variety of mattress weights and combinations of depth. The combination of mattress weight and depth determines the degree of assistance provided by the mechanism.
- B. Following installation of the mechanism lift / pull the base up and down a few times to free off the system - the gas cylinders fitted to the system may be stiff when first used or if the system has not been operated for a period of time. The mattress must be fitted to the base.
- C. Use the strap handle to lift up the mattress base using two hands - Pull the mattress base down using two hands equally spaced from the centre of the mattress base. **DO NOT** pull down on one side of the base only as this is likely to damage the base system with potential failure of the mattress base system and lift mechanism. **Do not operate the lift up mechanism without the mattress fitted to the base.**

CAUTION :

- Do not allow children to operate the lift Mechanism.
- Do not allow children near the lift base when operating the Mechanism.
- Do not allow children in the area of the internal storage base.
- Keep hands clear of the mechanism when operating the base system.
- Do not stand inside the bed / on the internal storage base.
- Do not overload the internal storage base.

Step 26

- Make sure the bed frame 4 side angles are at 90 degrees before you closing the lift base.

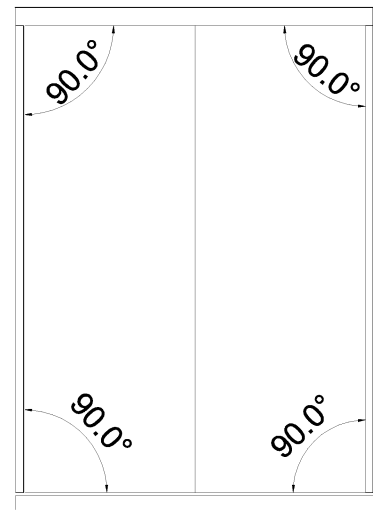
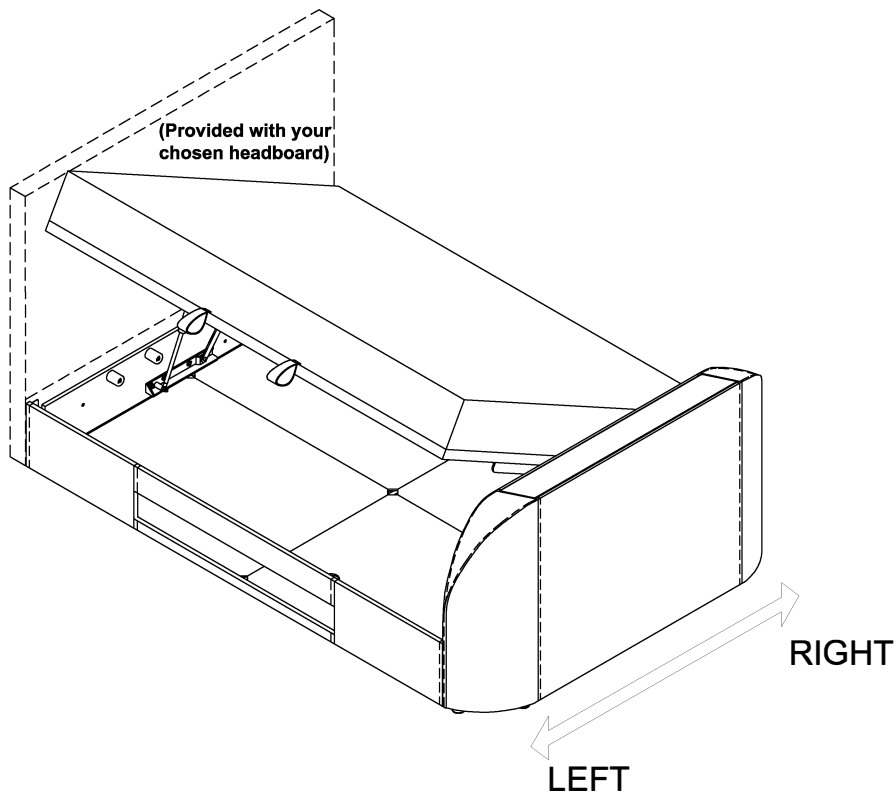

Step 27

- The mattress must be fitted on the lift base. (Do not operate the lift up mechanism without the mattress fitted on the lift base.)
- Lift the frame with the mattress, up and down at least 20 times before use.

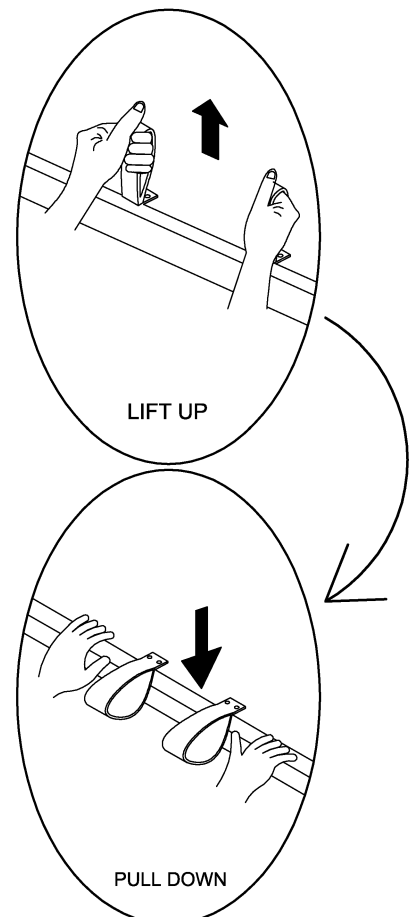
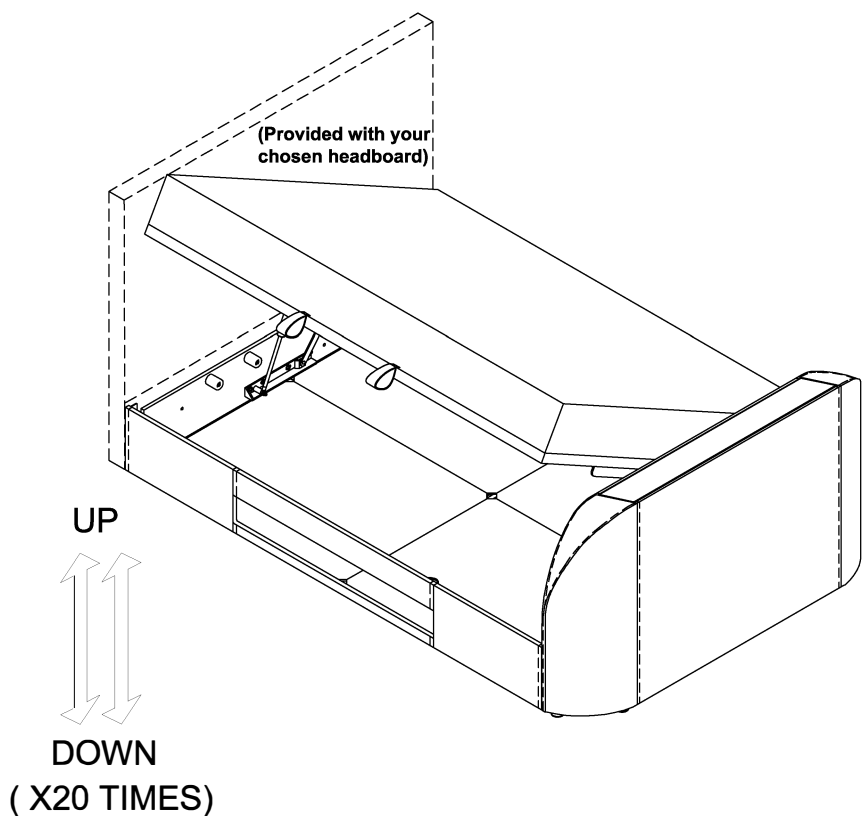

TROUBLE SHOOTING

TV LIFT DOES NOT OPERATE

CHECK

AC POWER ADAPTOR POWER CABLE (13) IS PLUGGED INTO A WORKING "SWITCHED ON" MAINS POWER SUPPLY.

THE OTHER END OF POWER ADAPTOR CABLE (11) IS PLUGGED FIRMLY INTO THE TV LIFT POWER CABLE.

THE AC POWER ADAPTOR (11) HAS AN ILLUMINATED GREEN "POWER ON" LED LIGHT.

YES

NO

CHECK THE WIRELESS REMOTE CONTROL BATTERIES ARE FITTED CORRECTLY AND WORKING

CHANGE THE 3A FUSE ON THE AC POWER ADAPTOR POWER CABLE PLUG (13).

YES

THE AC POWER ADAPTOR (11) NOW HAS AN ILLUMINATED GREEN "POWER ON" LED LIGHT.

PERFORM A RE-SYNC OF REMOTE CONTROL

TRY RE-SYNC AGAIN

CONTACT SUPPORT

YES

NO

TV LIFT IS NOW WORKING

CONTACT SUPPORT

YES

NO

PERFORM A RE-SYNC OF REMOTE CONTROL

TRY RE-SYNC AGAIN

CONTACT SUPPORT

SPECIFICATION-TV MECHANISM

FEATURE	Wireless Remote Control-TV LIFT MECHANISM
INPUT	100V-240V~ 50/60Hz 1500mA
OUTPUT	29V ---- 2A
DUTY CYCLE	MAX 10% ; MAX 2 min / 18 min
BATTERY (WIRELESS REMOTE CONTROL)	Size: AAA - Ø10.5 X T44.5mm - Spec.: 1.5V

G4 TV LIFT MECHANISM- OPTI-SERVE SPARE PARTS LIST

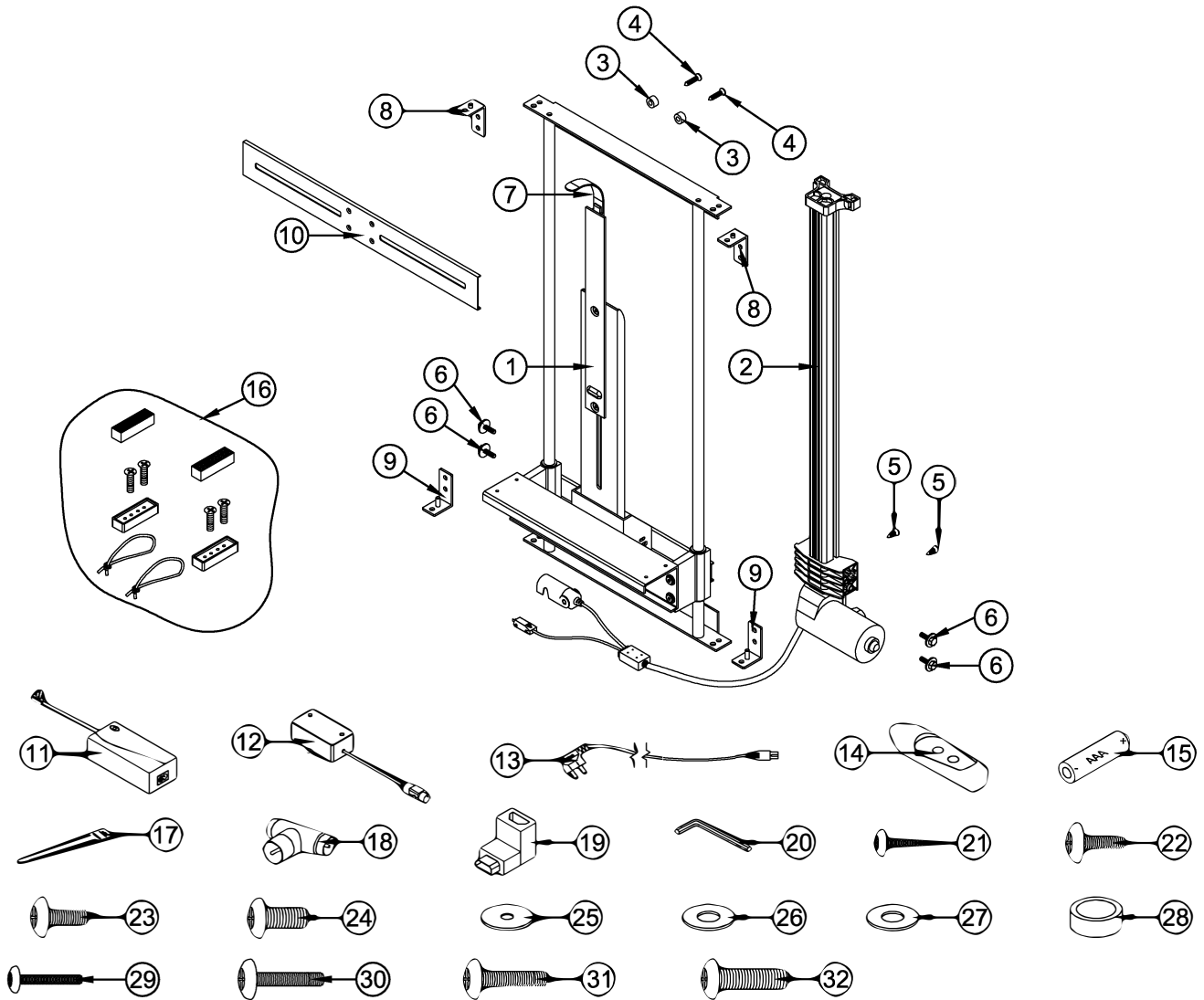

ITEM NO.	PART DESCRIPTION	IV CODES
1	Main TV-lift up mechanism (pre- assemble)	
2	TV-linear actuator G4 (pre-fixed)	
3	Actuator mounting top spacer (2pcs) (pre-fixed)	IV001281
4	Cross recessed countersunk flat head wood screw- Top mounting M6 x 30mm (2pcs) (pre-fixed)	IV001282
5	Cross recessed countersunk flat head wood screw- Top mounting M6 x 20mm (2pcs) (pre-fixed)	
6	Actuator mounting bolt- screw M6 x 20mm (4pcs) (pre-fixed)	
7	Gooseneck (pre-fixed)	IV001289
8	Top hanging bracket (2pcs) (pre-fixed)	
9	Bottom hanging bracket (2pcs) (pre-fixed)	IV001636
10	TV- flat bracket (Vesa Bracket) (pre-fixed)	IV001290
11	TV-lift up mechanism AC/ DC adapter	IV001291
12	TV lift-up mechanism control box (pre-fixed)	IV001293
13	TV-lift up mechanism AC/ power-cable power plug UK	IV001295
14	Wireless remote control	IV001302
15	Battery (2pcs)	IV000991
16	TV block (2pcs), screw M4 x 35mm (4pcs), block rubber cover (2pcs), cable management bungee cable (2pcs) (pre-fixed)	IV001635
17	Cable clip (2pcs)-use to fix wire	
18	Aerial connection (1pc)	
19	90 degree HDMI adaptor (1pc)	
20	Allen key (M4) (1pc)	
21	Pan head screw M4 x 20mm (2pcs)	
22	Pan head screw M5 x 20mm (2pcs)	
23	Pan head screw M6 x 20mm (2pcs)	
24	Pan head screw M8 x 20mm (2pcs)	IV001634
25	M5 washer (2pcs)	
26	M6 washer (2pcs)	
27	M8 washer (2pcs)	
28	Plastic collar (6pcs)	
29	Pan head screw M4 x 40mm (2pcs)	
30	Pan head screw M5 x 40mm (2pcs)	
31	Pan head screw M6 x 40mm (2pcs)	
32	Pan head screw M8 x 40mm (2pcs)	

Important for Ottoman and other gas lift beds

Please follow these final steps to ensure the best experience with your new bed

- Please ensure the pistons are fitted to the bed frame.
- Please place the mattress on top of the bed frame.
- Standing at the foot of the frame (looking at the headboard) open the base and the press quite forcefully down on the mattress - please do not attempt to do this without the mattress being in place.
- Please do not pull on the strap handles.
- Please note as the pistons are full of gas - you will need to press heavily to release the compressed gas.
- Once done the pistons should start operating as normal.



Please dispose of all packaging safely.

General Care & Maintenance

Wipe clean with a slightly damp cloth.
Avoid the use of all household cleaners and abrasives.

Periodically check all screw & fixings to ensure they are secure.

When moving your product, carefully lift into place. Never drag or push the product across the floor as this will cause damage to the joints. If the product is used on hard flooring, such as wood or laminated floor, you must place some protection under the legs to stop the product from moving. If this is not adhered to, it could result in failure to the product that will invalidate the warranty.

For more information on cleaning and product care visit:
<https://www.happybeds.co.uk/help-and-advice>

Notes

In the unlikely event that you have problems putting this product together or have damaged or missing parts, please contact us by visiting:
<https://www.happybeds.co.uk/customer-service>