

Assembly Instructions

Important before assembly:

Read these instructions carefully before assembling or using the product.

Please check the contents of the boxes before attempting to assemble this product. The instructions will have a checklist of parts and fittings.

Assemble the product as close to its intended final location/room as possible.

Health & Safety:

This product or some parts of this product will be heavy. Please use an assistant when lifting.

Please keep small parts out of reach of children.

Always use on a level, even surface.

DO NOT jump on the product or any of its parts.

DO NOT use this product if any parts are missing, damaged or worn.

DO NOT use this product unless all fixings are secured.

Further instructions are on the following pages.

Please keep these instructions for future reference.



This product or some parts of this product will be heavy. Please use an assistant when lifting.



Never drag or push the pieces across a hard or stone floor as this will cause damage to the joints. Use a carpet or a rug for extra care.

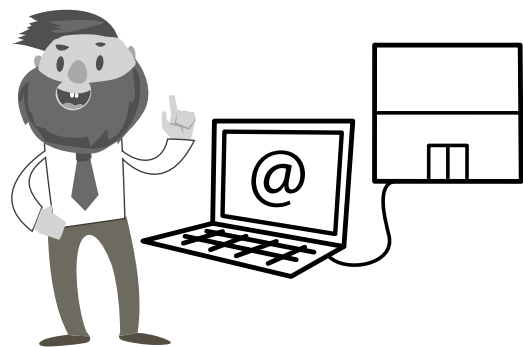

If you have problems assembling or have damaged or missing pieces, please contact our customer services (details at the back of these instructions)

Please check all hardware matches the list below. Should you notice any are missing please contact your retailer.

(A)



Cam Stud
80PCS

(B)



Cam
92PCS

(C)

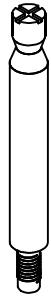

Contractfix Dowel
12PCS

(D)



M8 x 25mm
103PCS

(E)



M3.5 x 14mm
36PCS

(G)



M6 x 13mm
14PCS

(H)

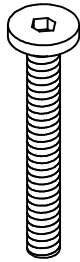

M6 x 50mm
10PCS

(J)

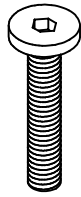

M6 x 35mm
20PCS

(K)

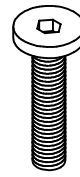

M6 x 30mm
30PCS

(Q)



M6 Round Nut
8PCS

(R)

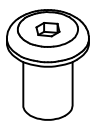

M6
6PCS

(S)



Shelf Support
4PCS

(T)

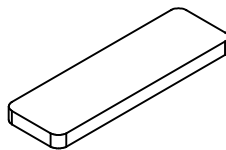

Felt Pads
30PCS

(U)



Sticker
22PCS

(V)



Hole Plug 10mm
2PCS

We strongly advise that you do not use Power Tools, such as drills or electric screwdrivers during the assembly as this may cause irreparable damage and will invalidate your warranty.



Please check all hardware matches the list below. Should you notice any are missing please contact your retailer.

F

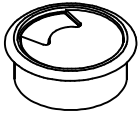

PVC Cap
1PCS

L

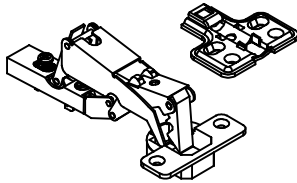

Hinges Arm
6 SET

M

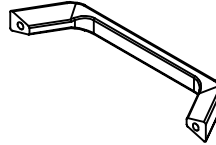

Handle
2PCS

N



M4 x 18mm
4PCS

P



PVC Hook
2PCS

W

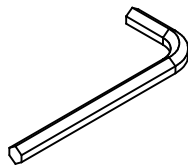

M4
2PCS

We strongly advise that you do not use Power Tools, such as drills or electric screwdrivers during the assembly as this may cause irreparable damage and will invalidate your warranty.



PARTS

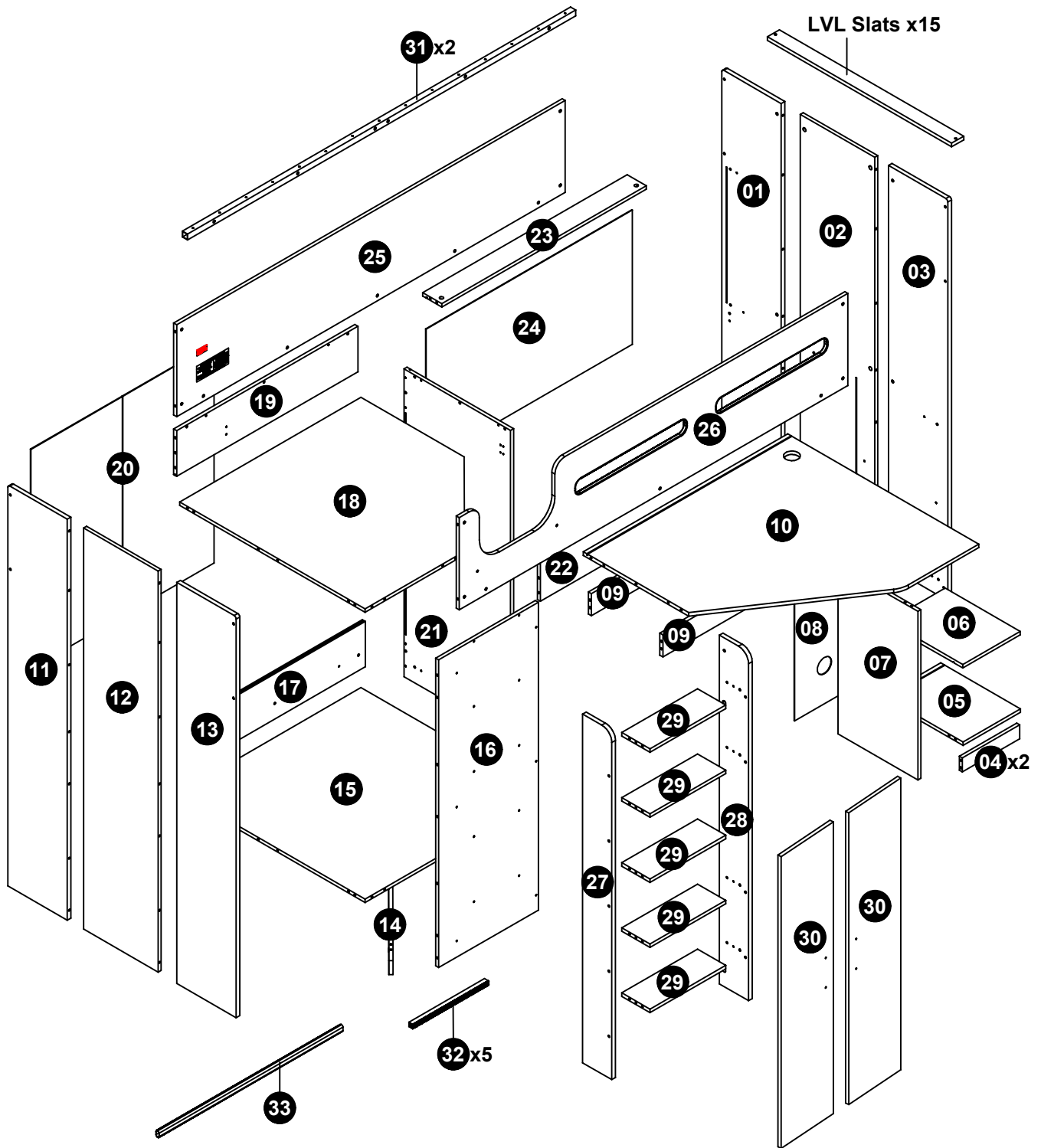

Please ensure you carefully check all the pieces, should you have any concerns please contact the retailer before assembly commences.

Please have your order number, details of the issue, the product code, and the batch number from the cartons as this will help us to resolve your issue much faster.

1

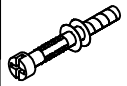

A x 10



G x 6

WHEN FITTING CAMS
ENSURE STARTING POSITION IS CORRECT
BEFORE YOU INSERT CONNECTING BOLT
TURN CLOCKWISE UNTIL SECURE

✓ **CORRECT**

✗ **WRONG**



B x 6



S x 2

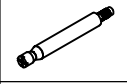

C x 6

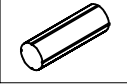
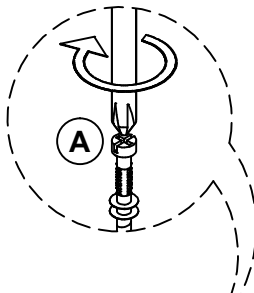

D x 8

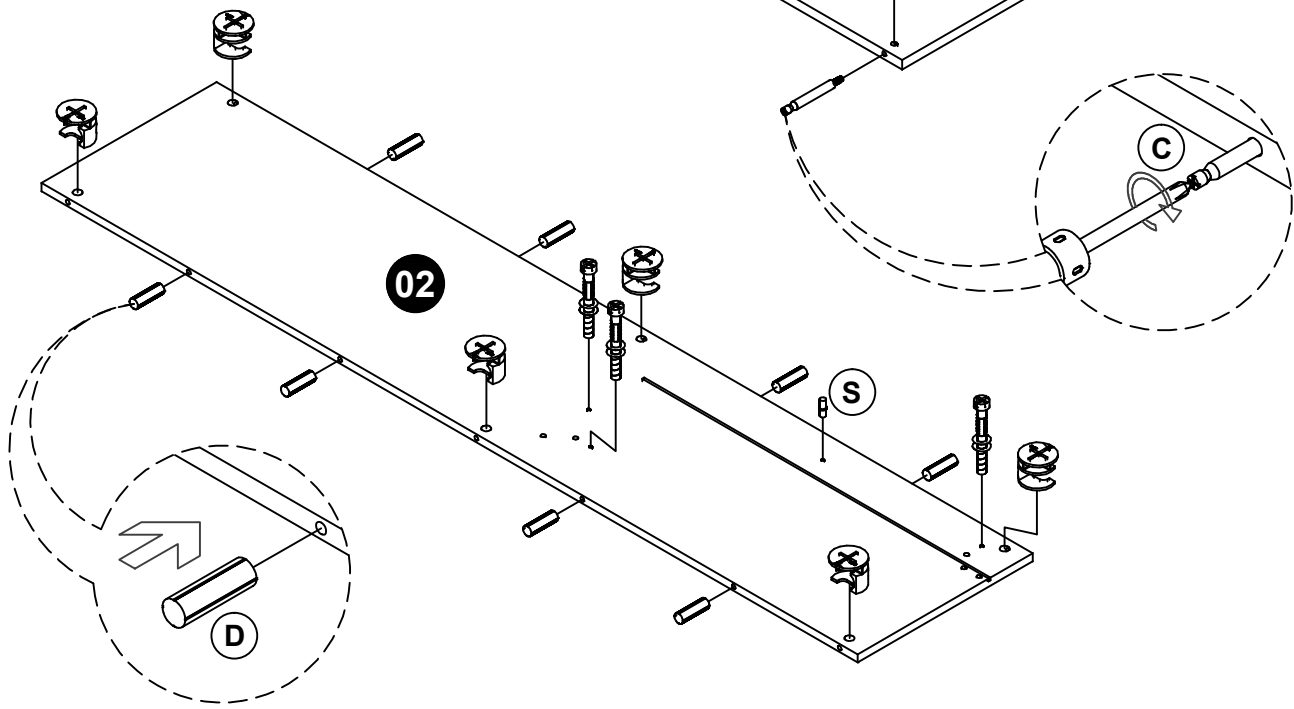
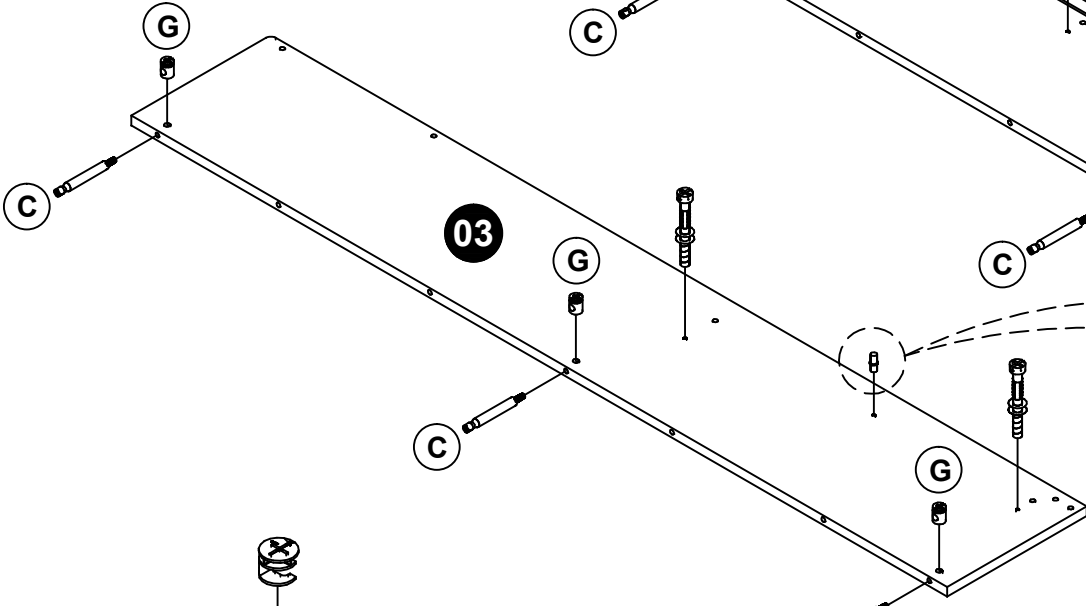
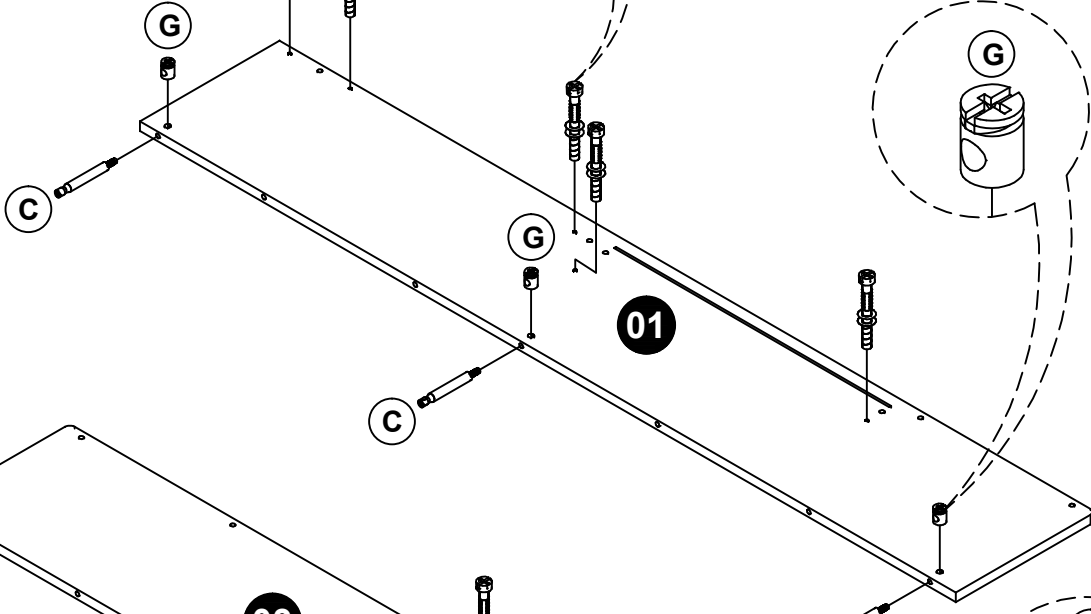

2

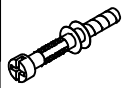

A x 6



B x 19



D x 32



S x 2



WHEN FITTING CAMS

ENSURE STARTING POSITION IS CORRECT
BEFORE YOU INSERT CONNECTING BOLT
TURN CLOCKWISE UNTIL SECURE

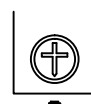

CORRECT

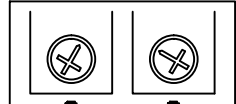

WRONG

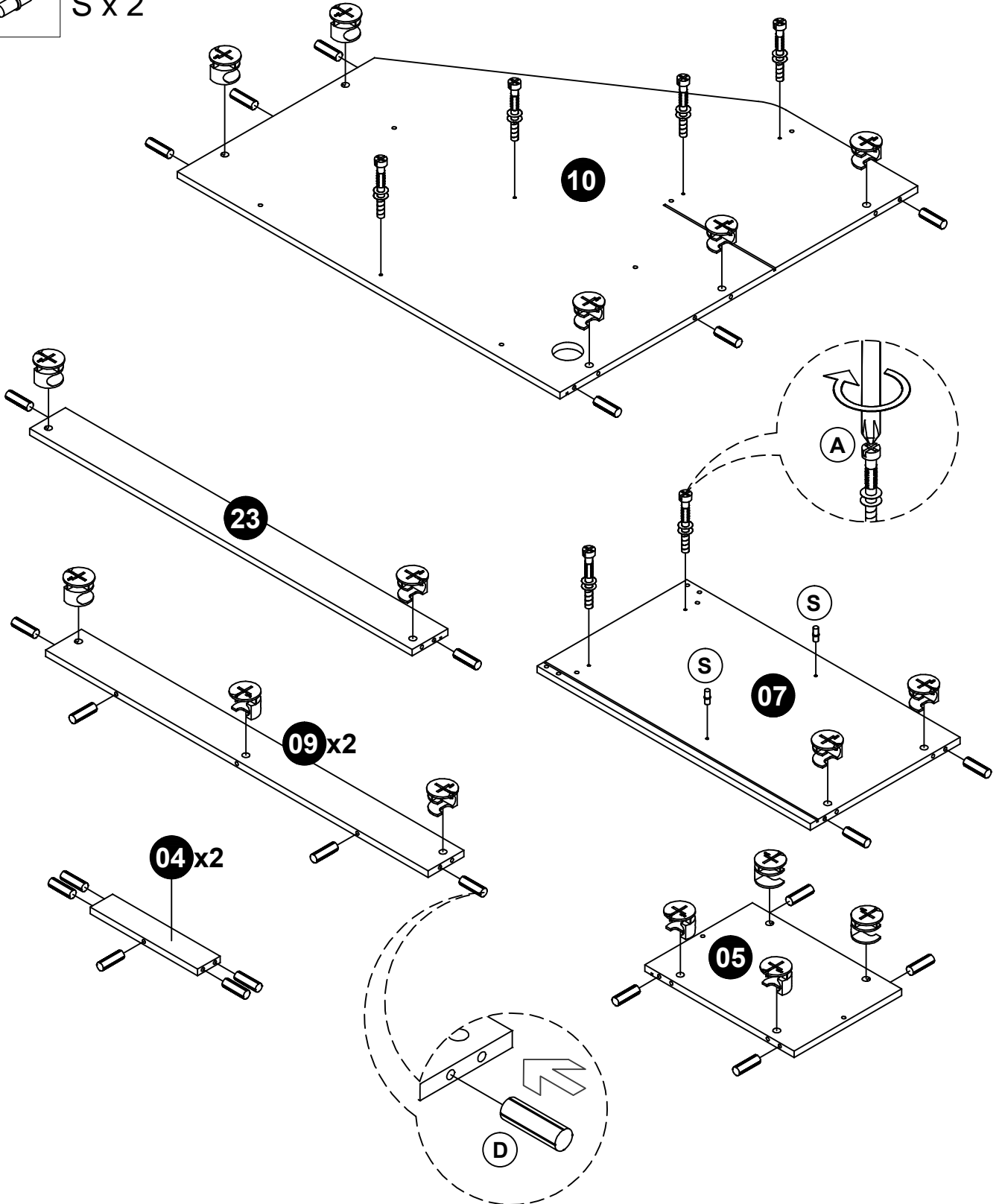

3

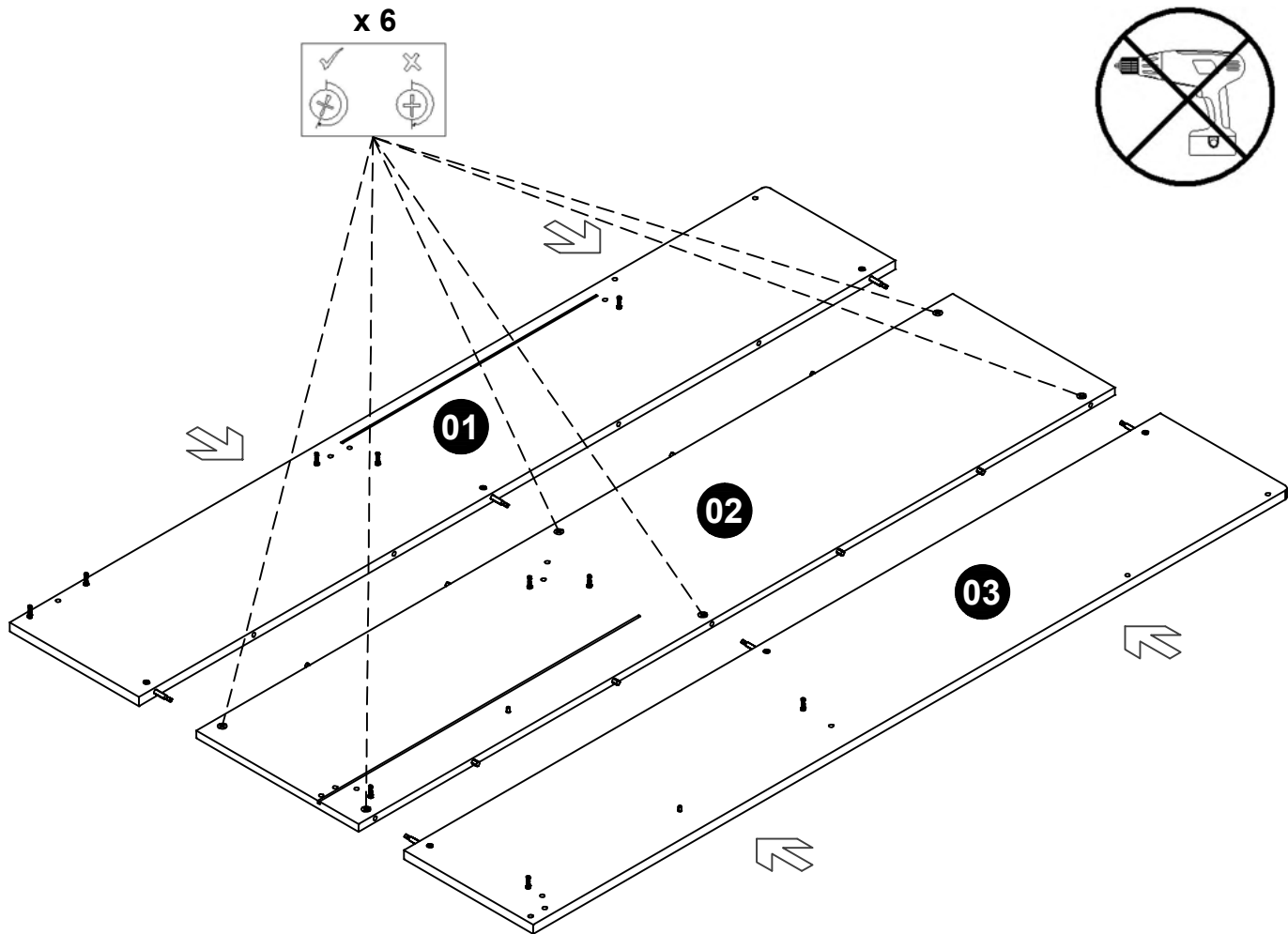

4



U x 8

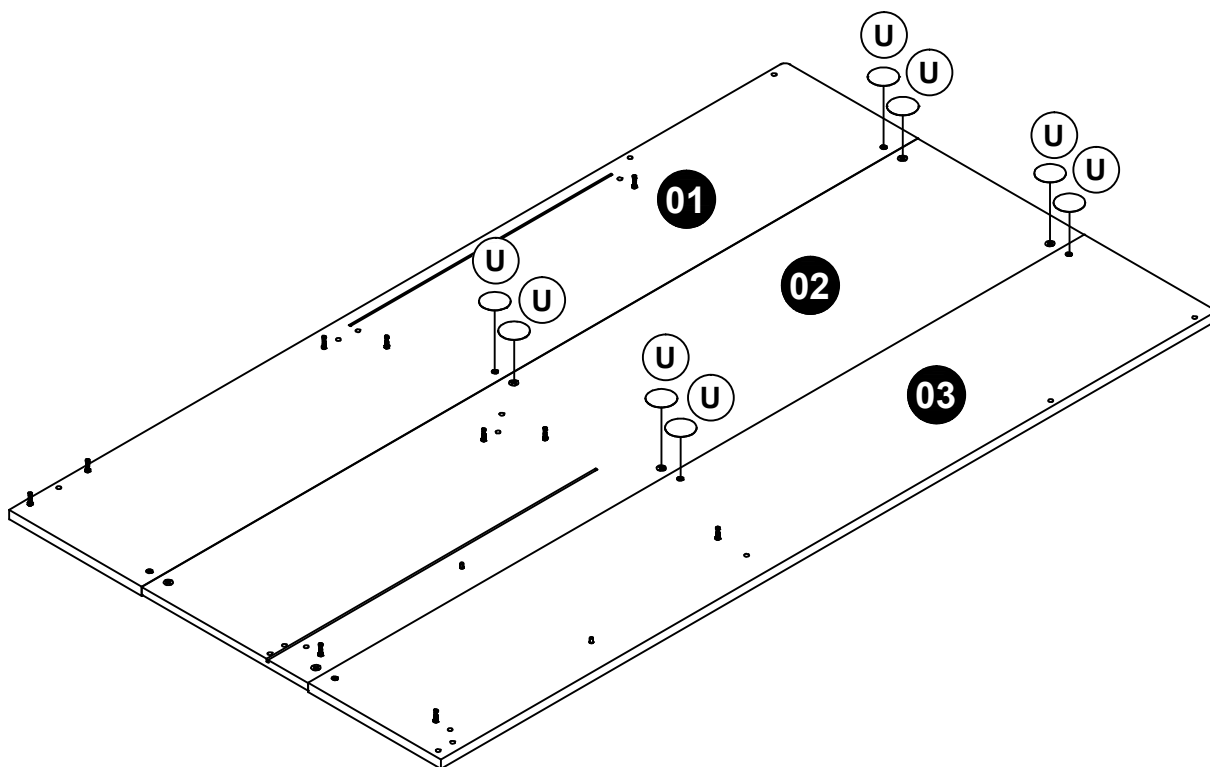

5

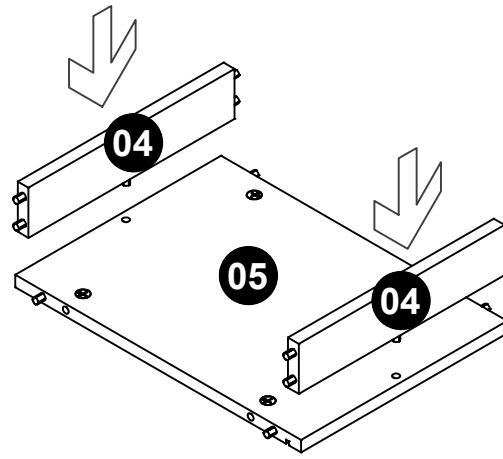

6

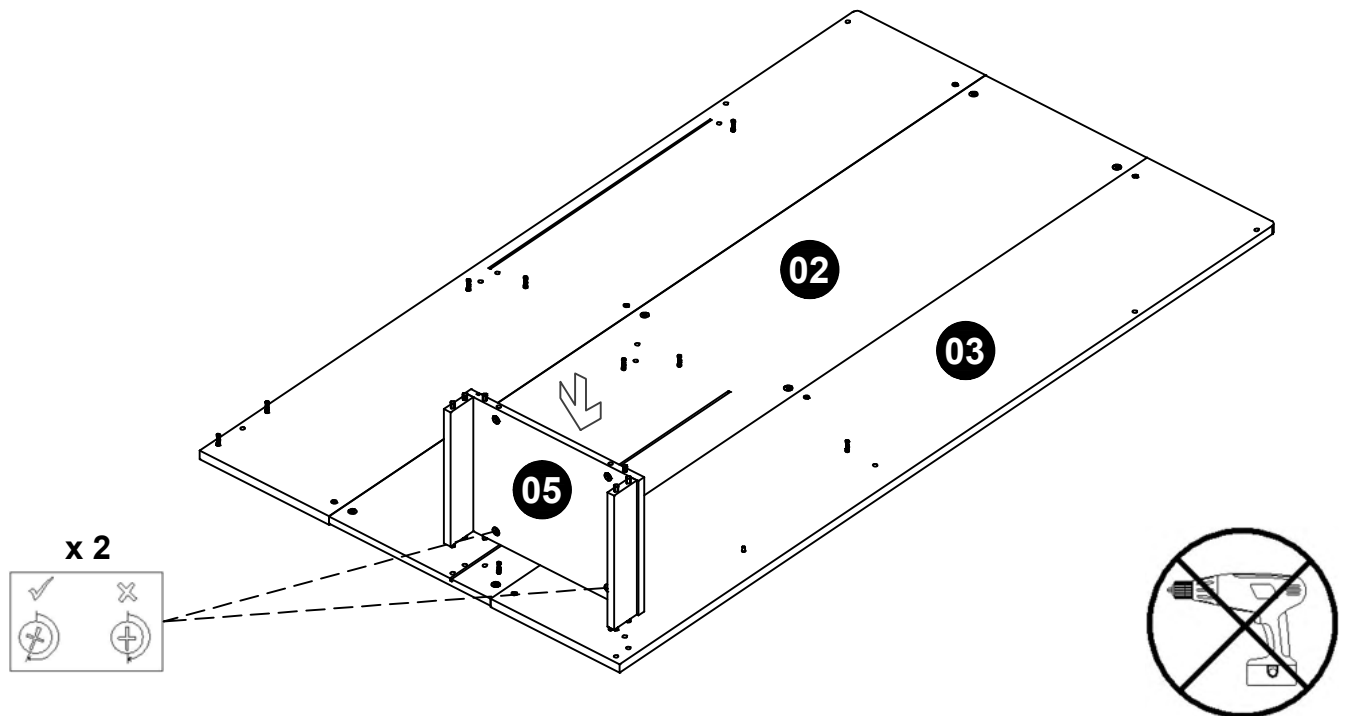

7

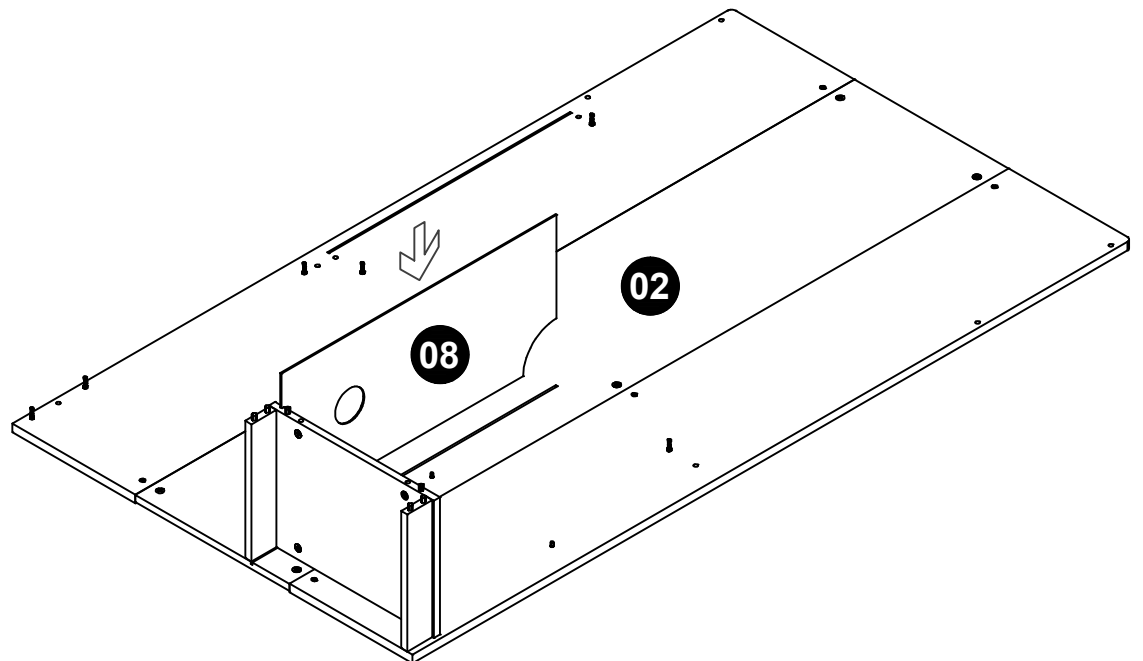

8

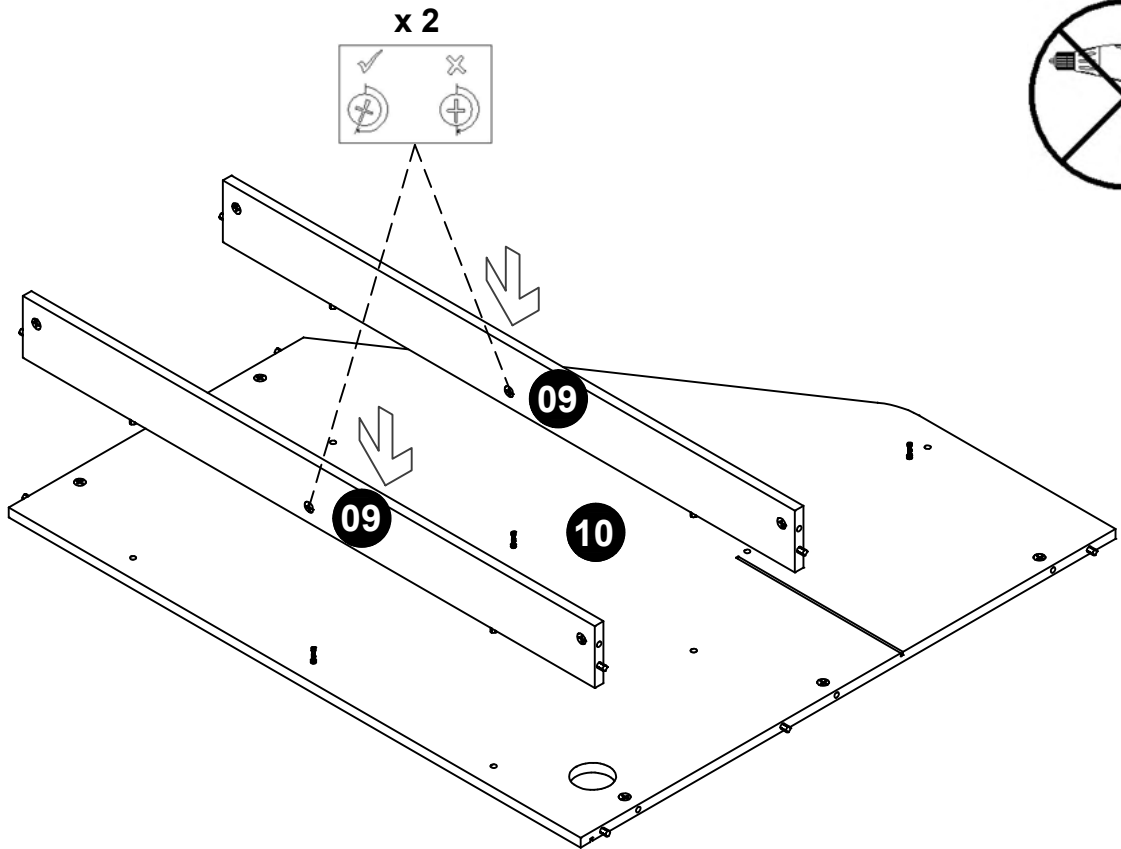

9

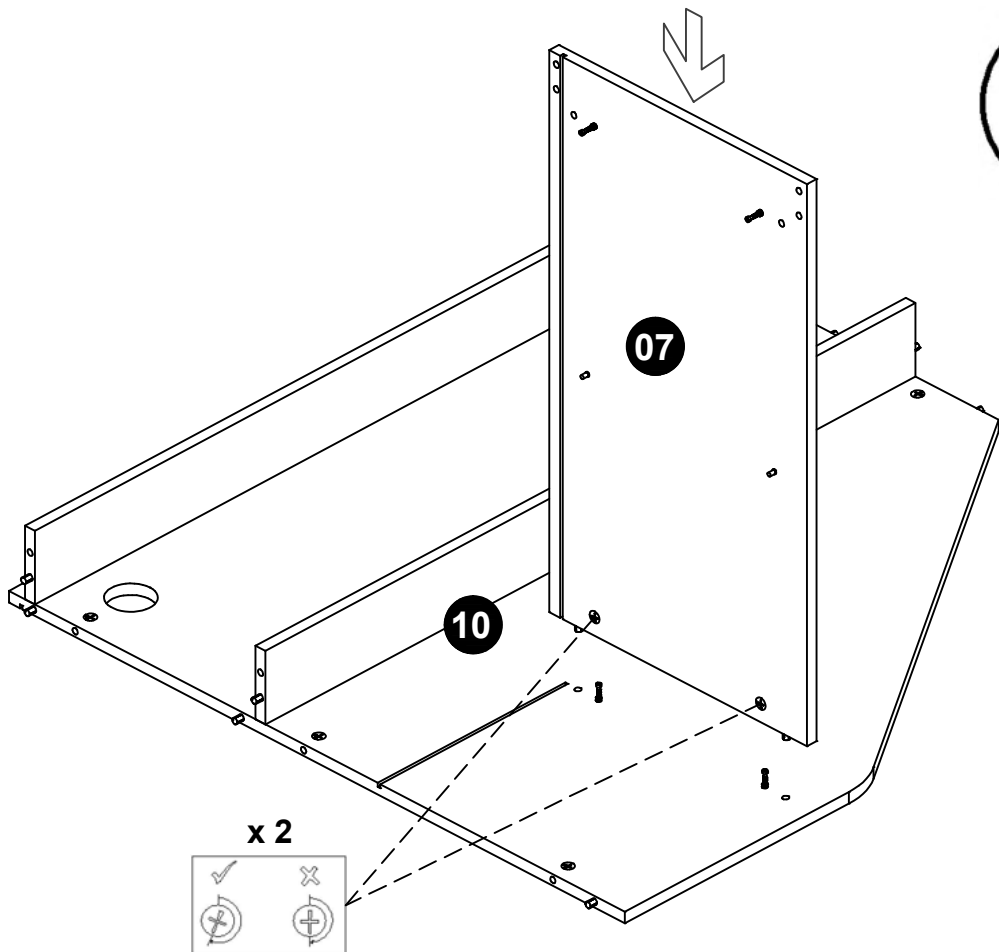

10

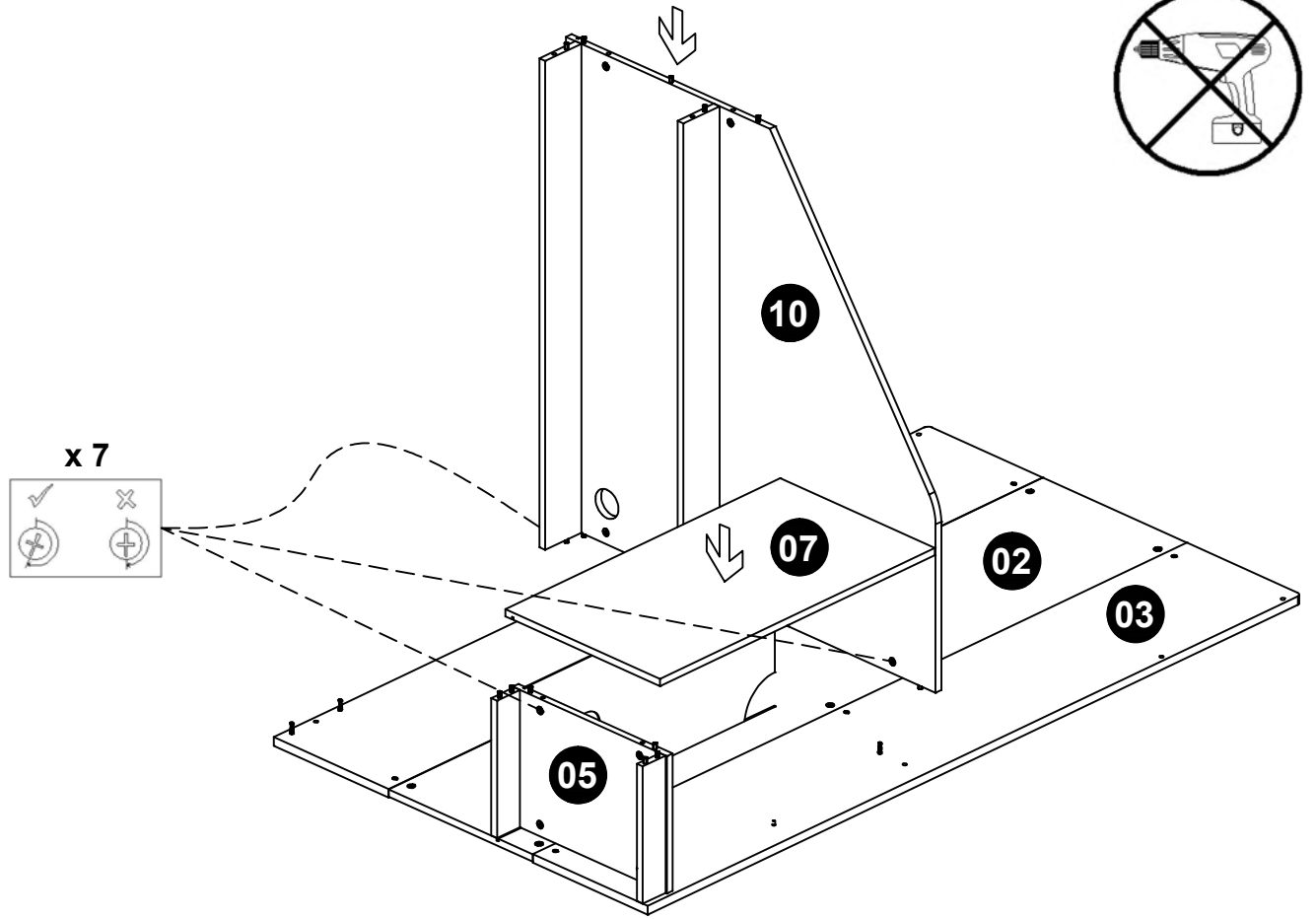

11

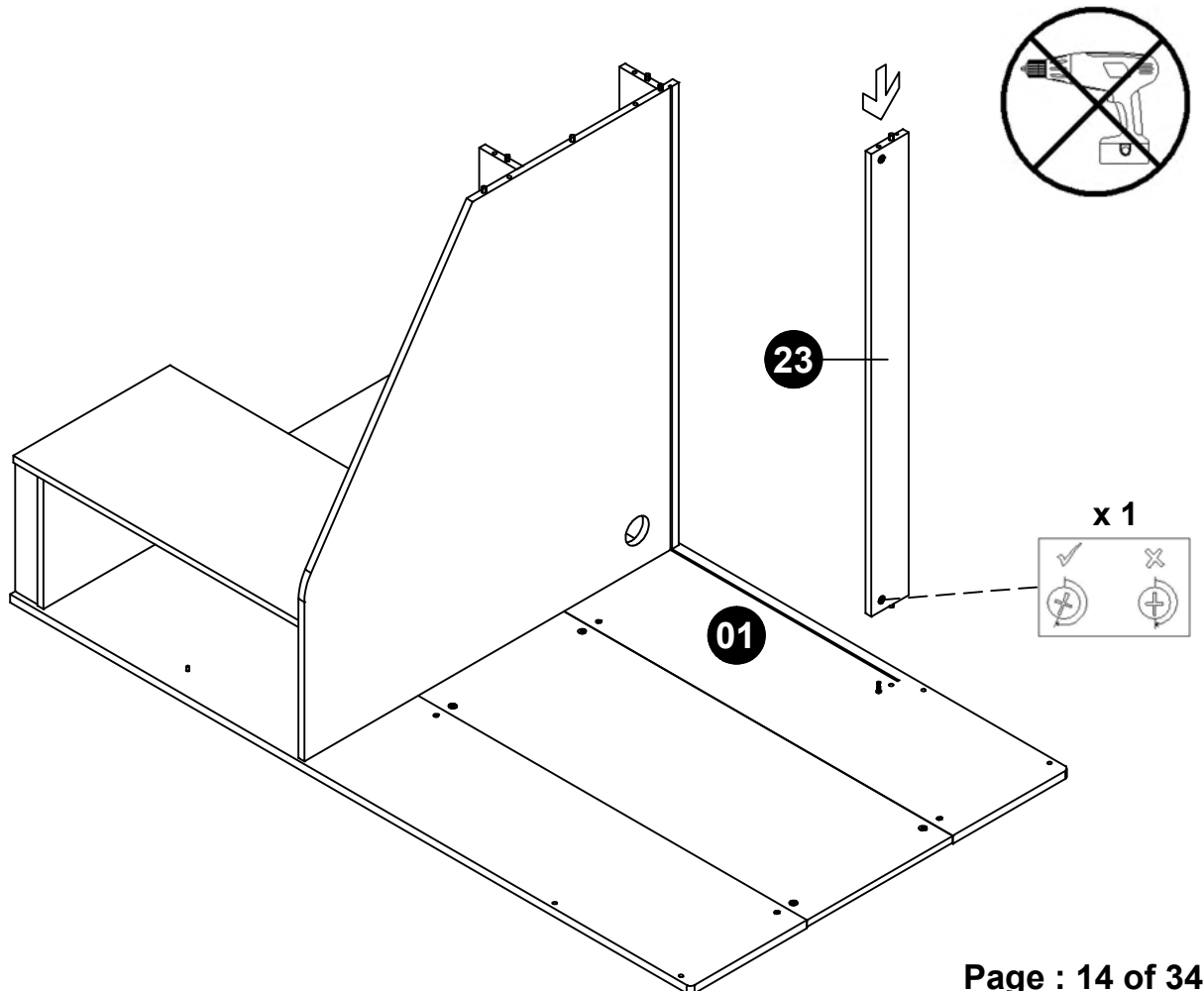

12

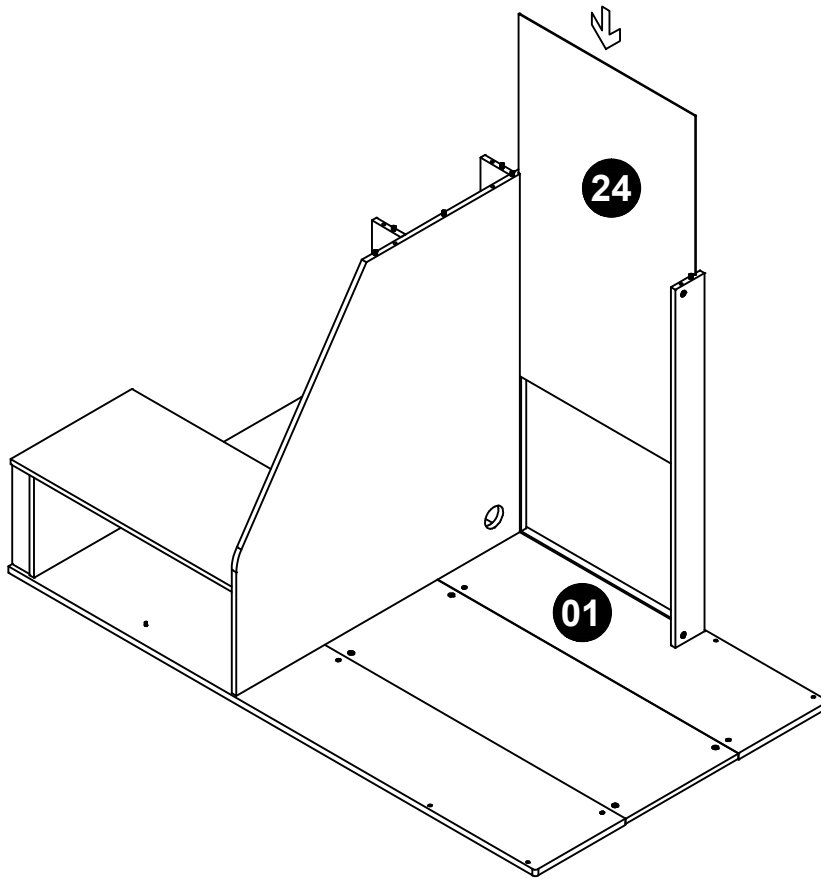

13



T x 10

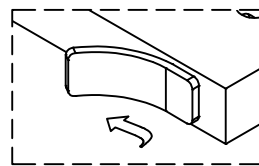

Part 01, 02, 03, 07

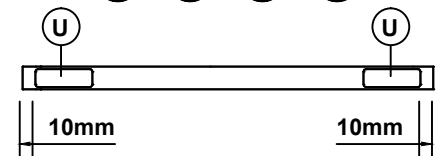

Part 04

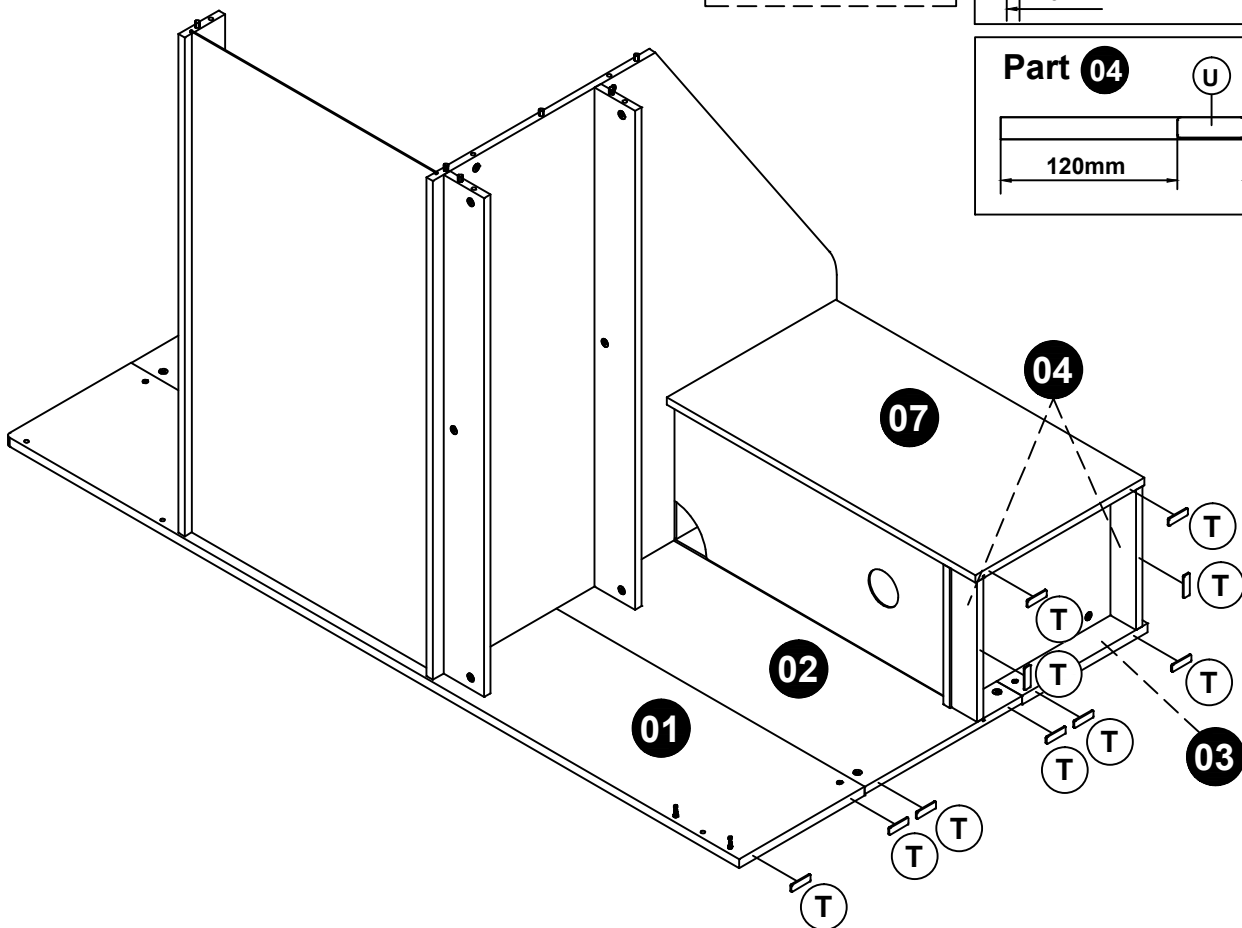
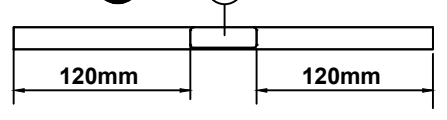

14

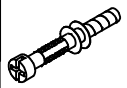

A x 13



G x 6



B x 6

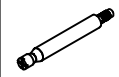

C x 6

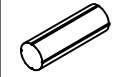

D x 8

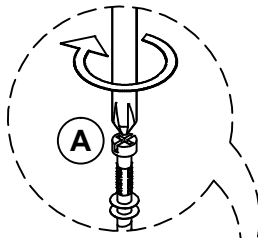

WHEN FITTING CAMS
ENSURE STARTING POSITION IS CORRECT
BEFORE YOU INSERT CONNECTING BOLT
TURN CLOCKWISE UNTIL SECURE

✓ X

↑

CORRECT WRONG

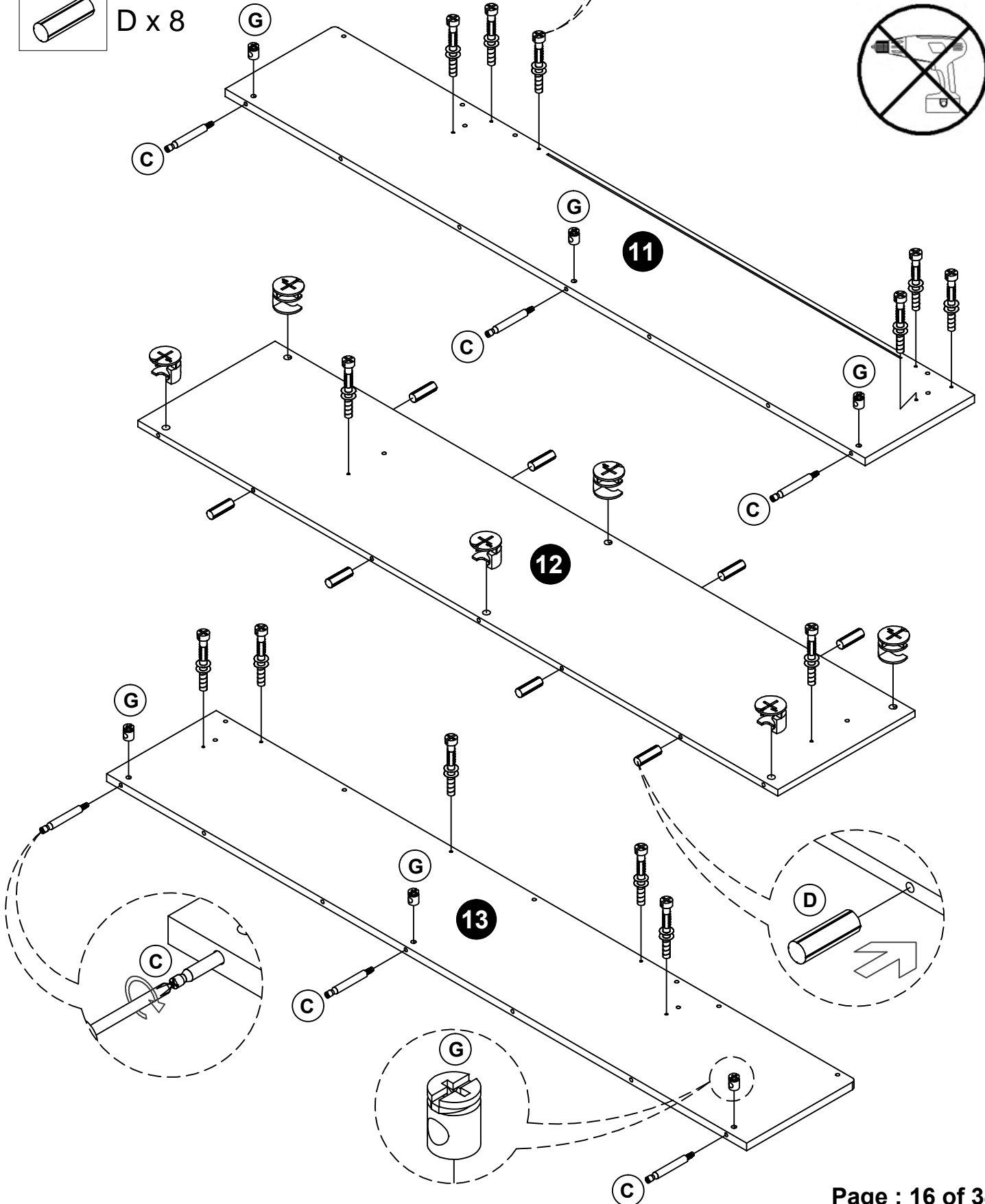

15

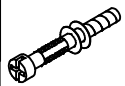

A x 18



B x 35



D x 35



P x 2



T x 2

WHEN FITTING CAMS
 ENSURE STARTING POSITION IS CORRECT
 BEFORE YOU INSERT CONNECTING BOLT
 TURN CLOCKWISE UNTIL SECURE

✓ X
 ↑ A
 CORRECT WRONG

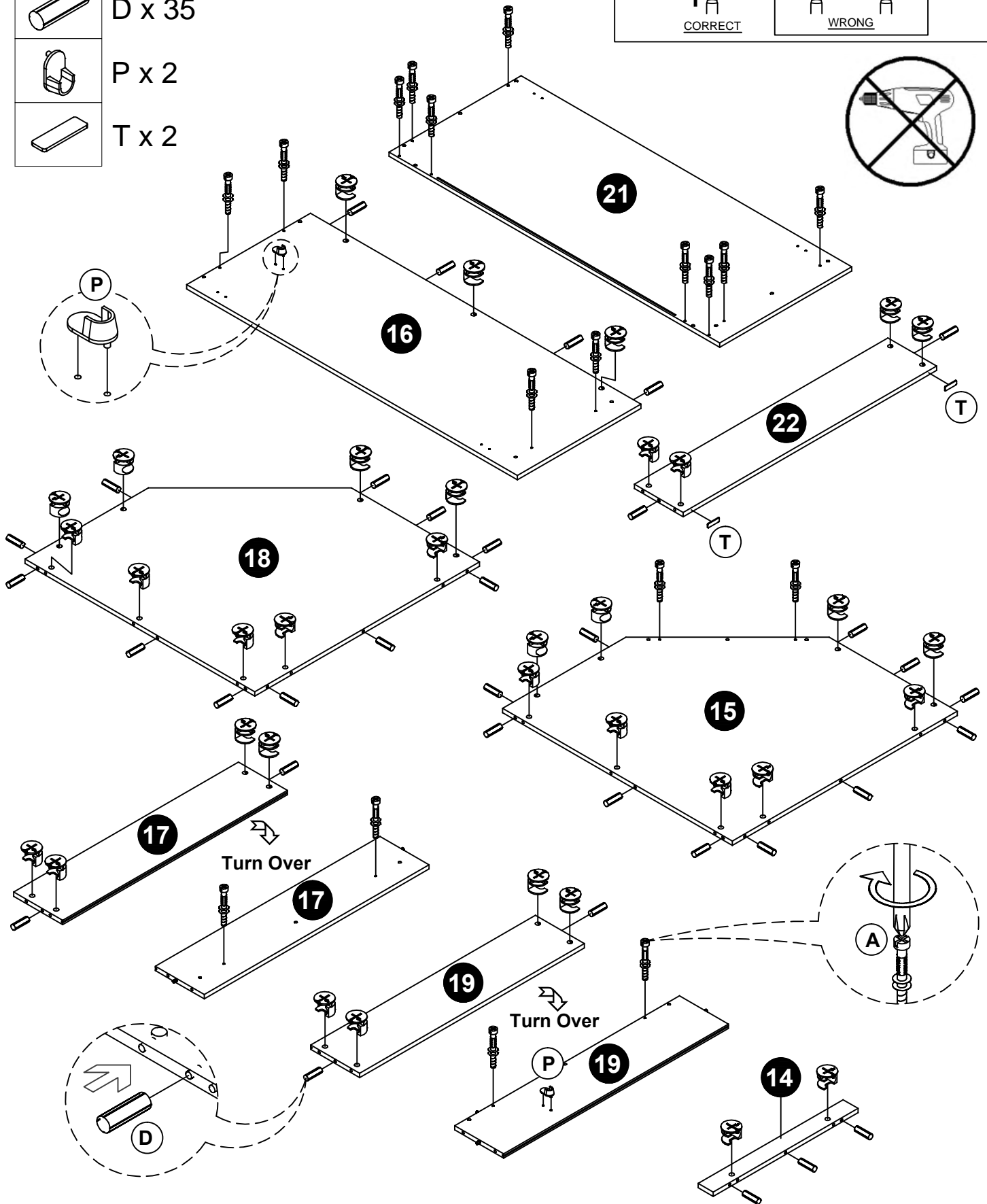

16



E x 12



L x 3

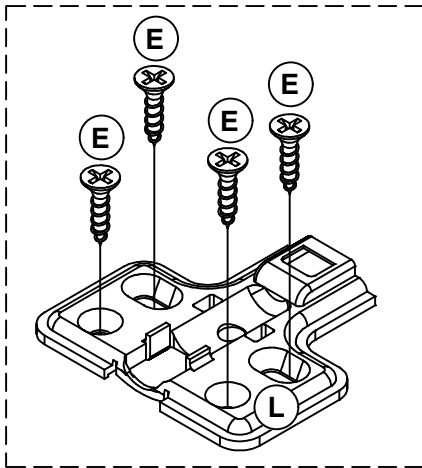
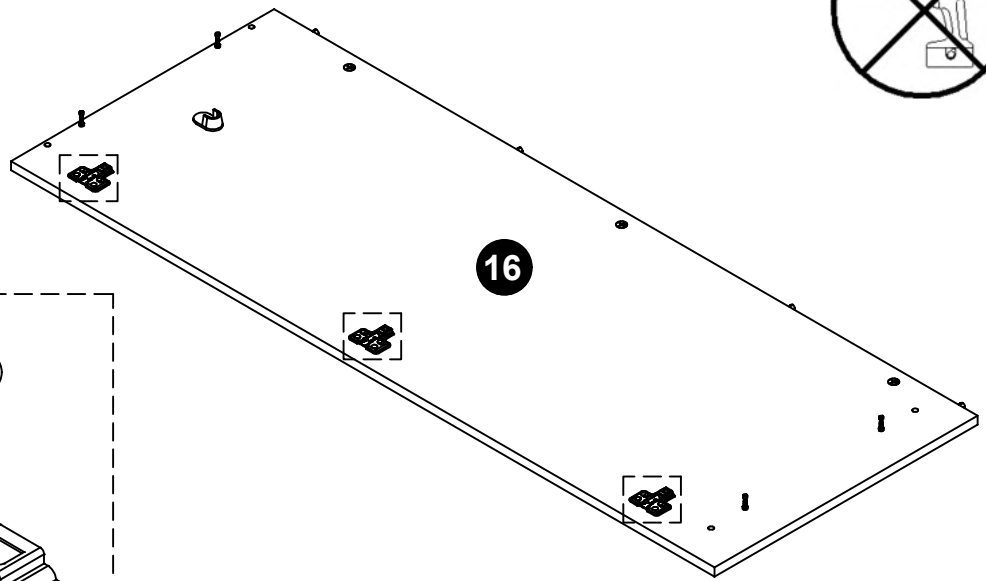

17



E x 12



L x 3

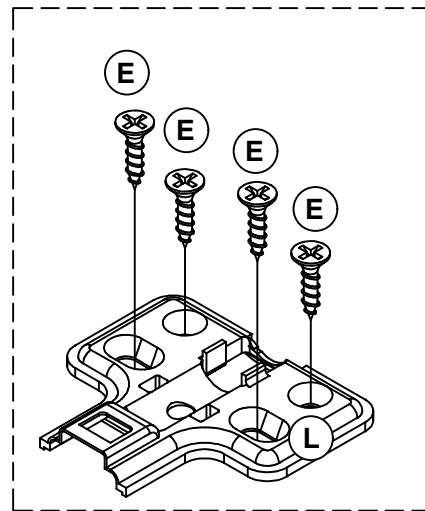
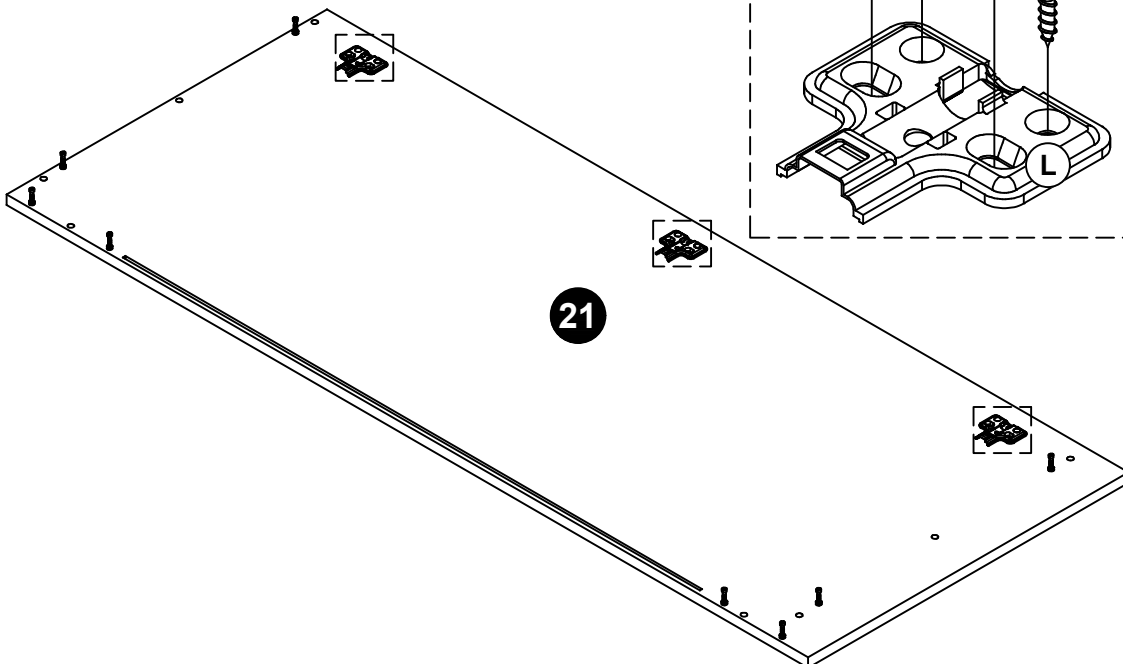

18

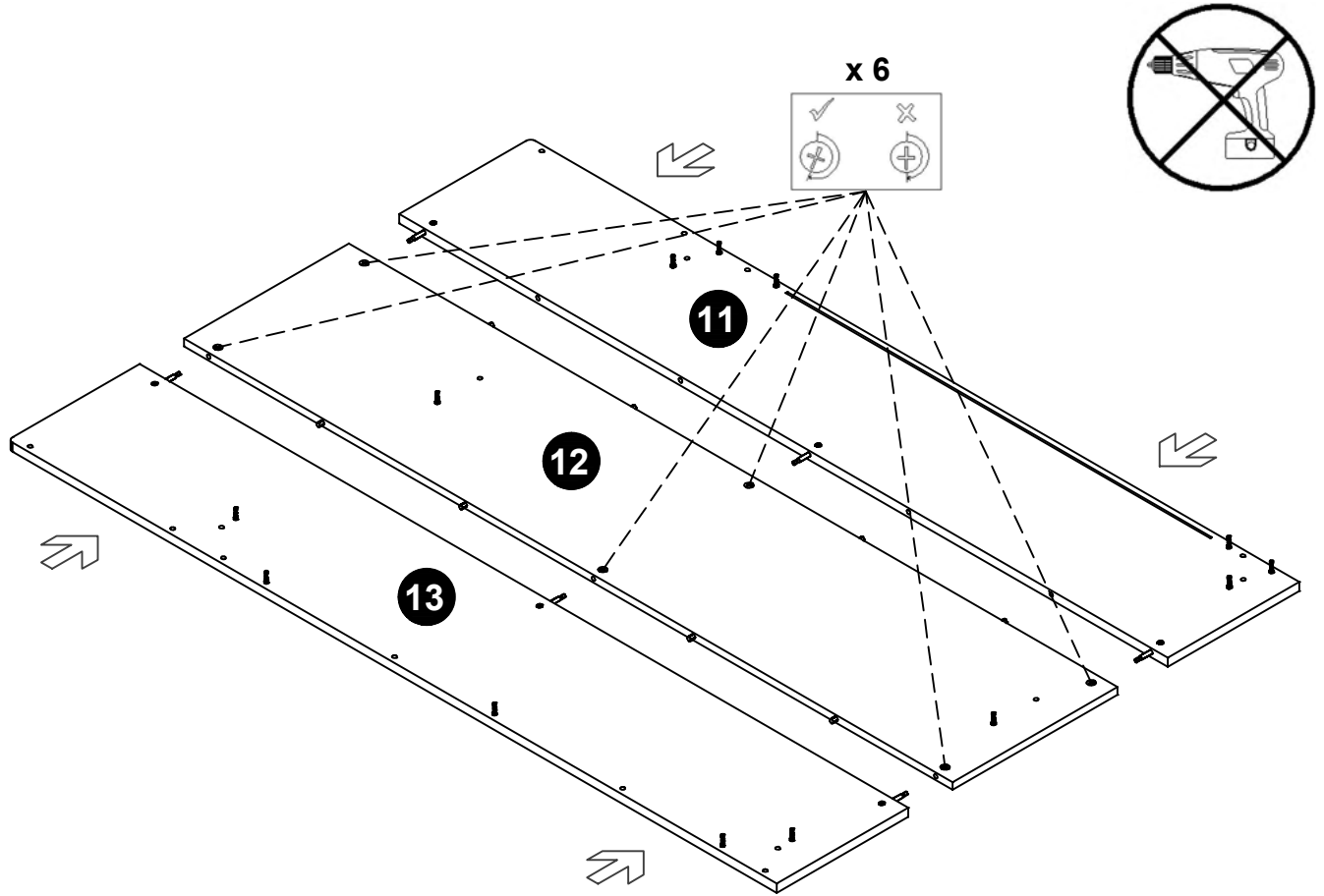

19



U x 8

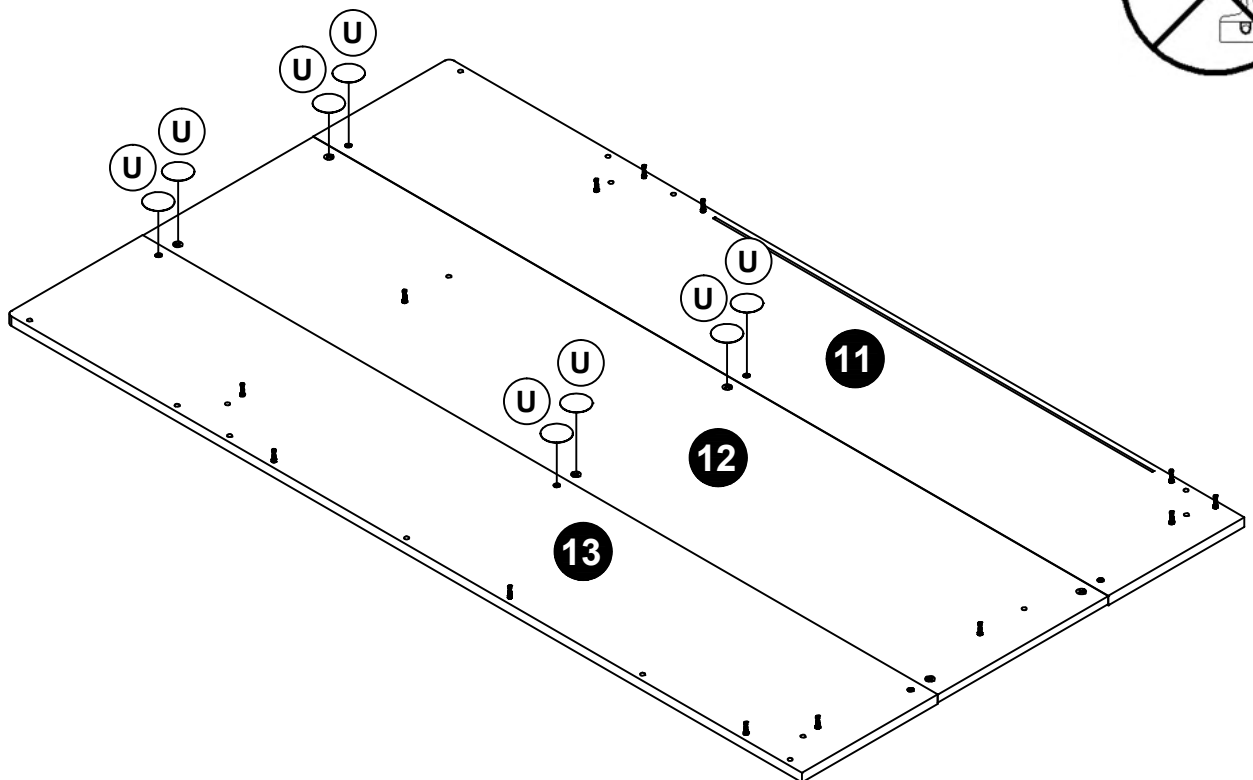

20

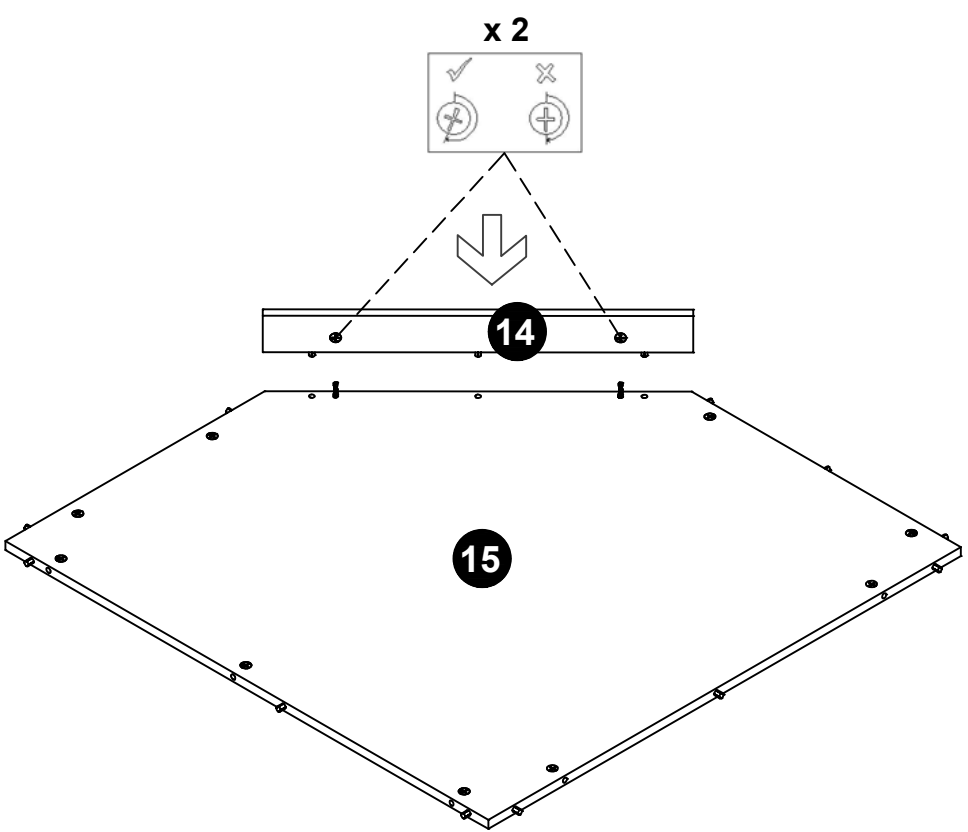

21

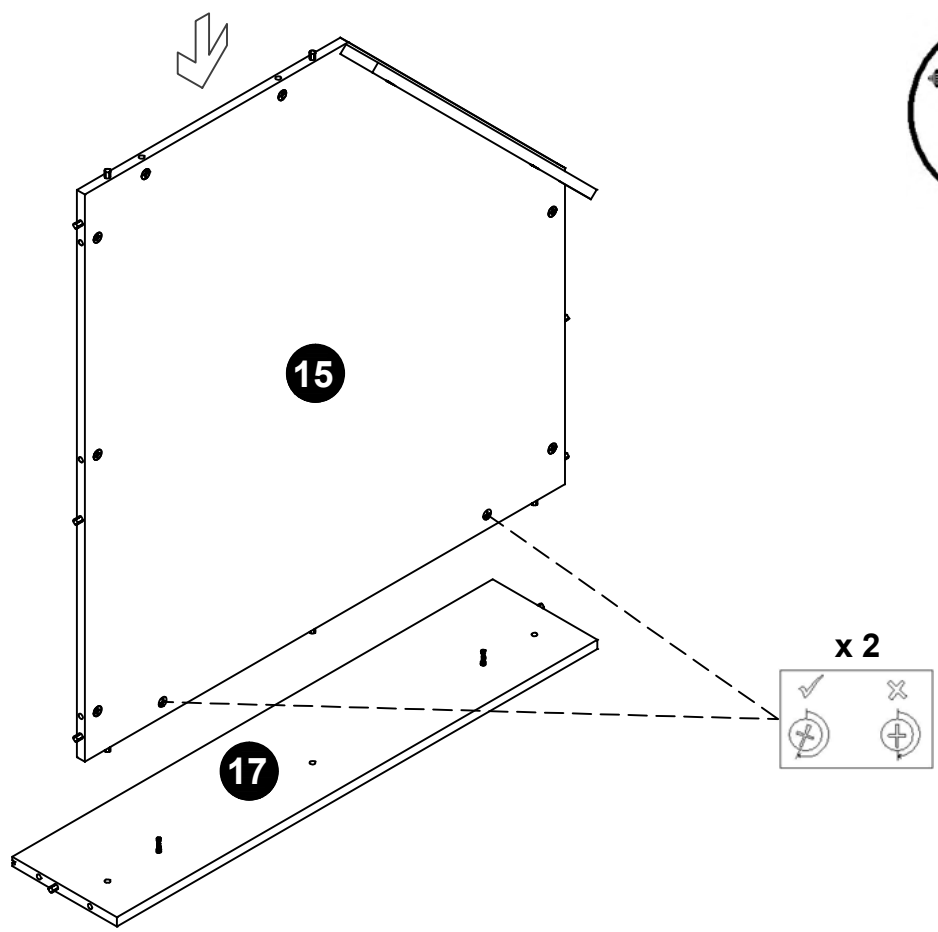

22

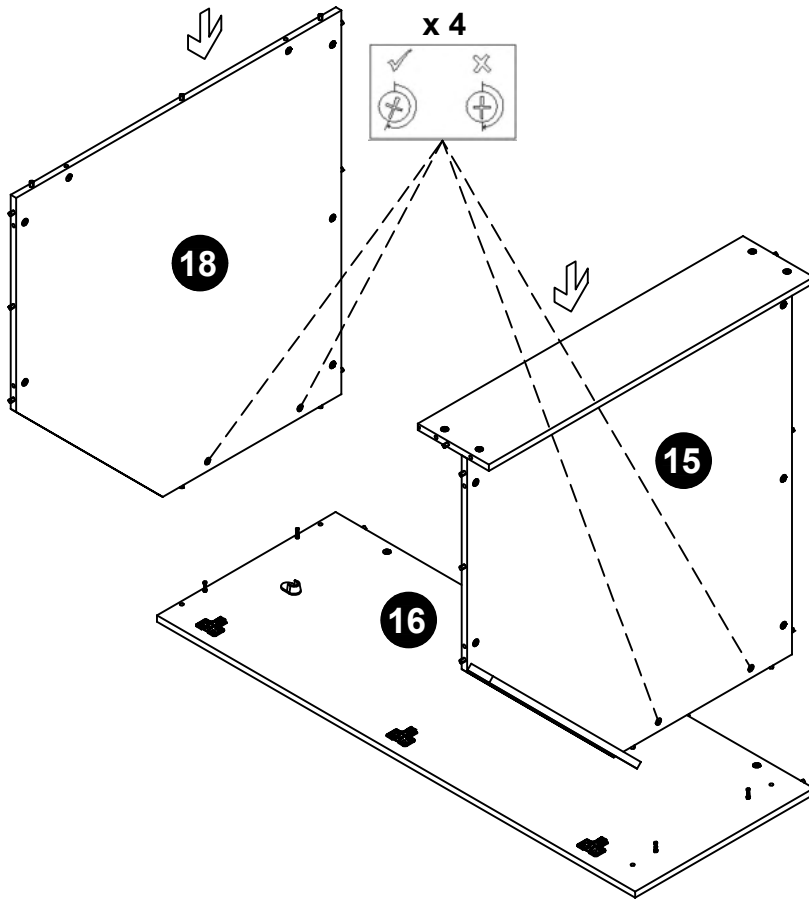

23

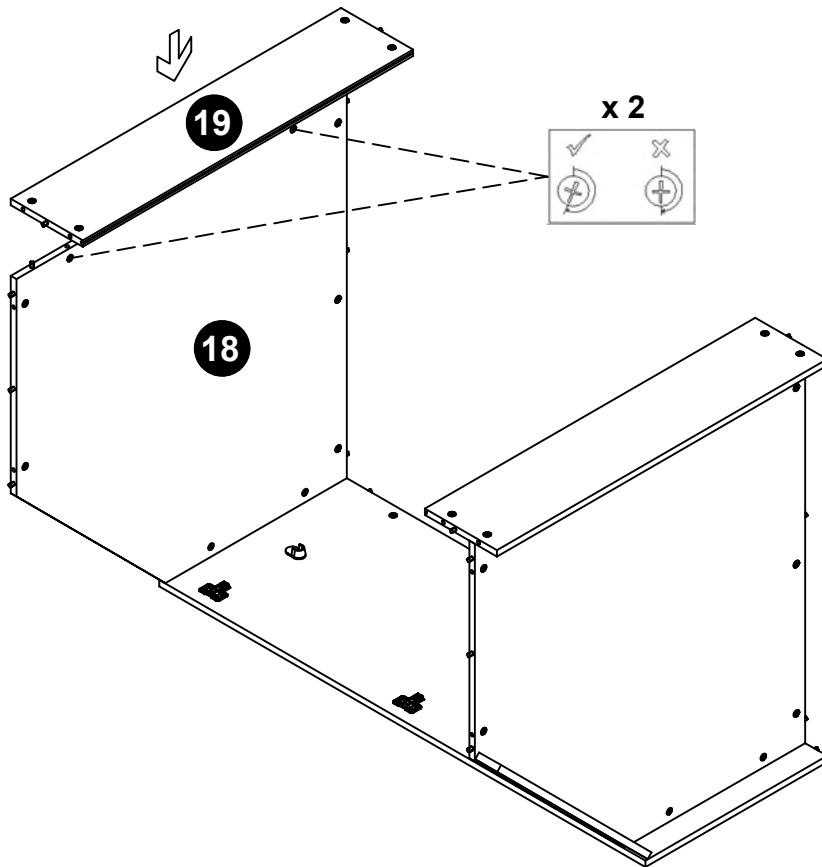

24

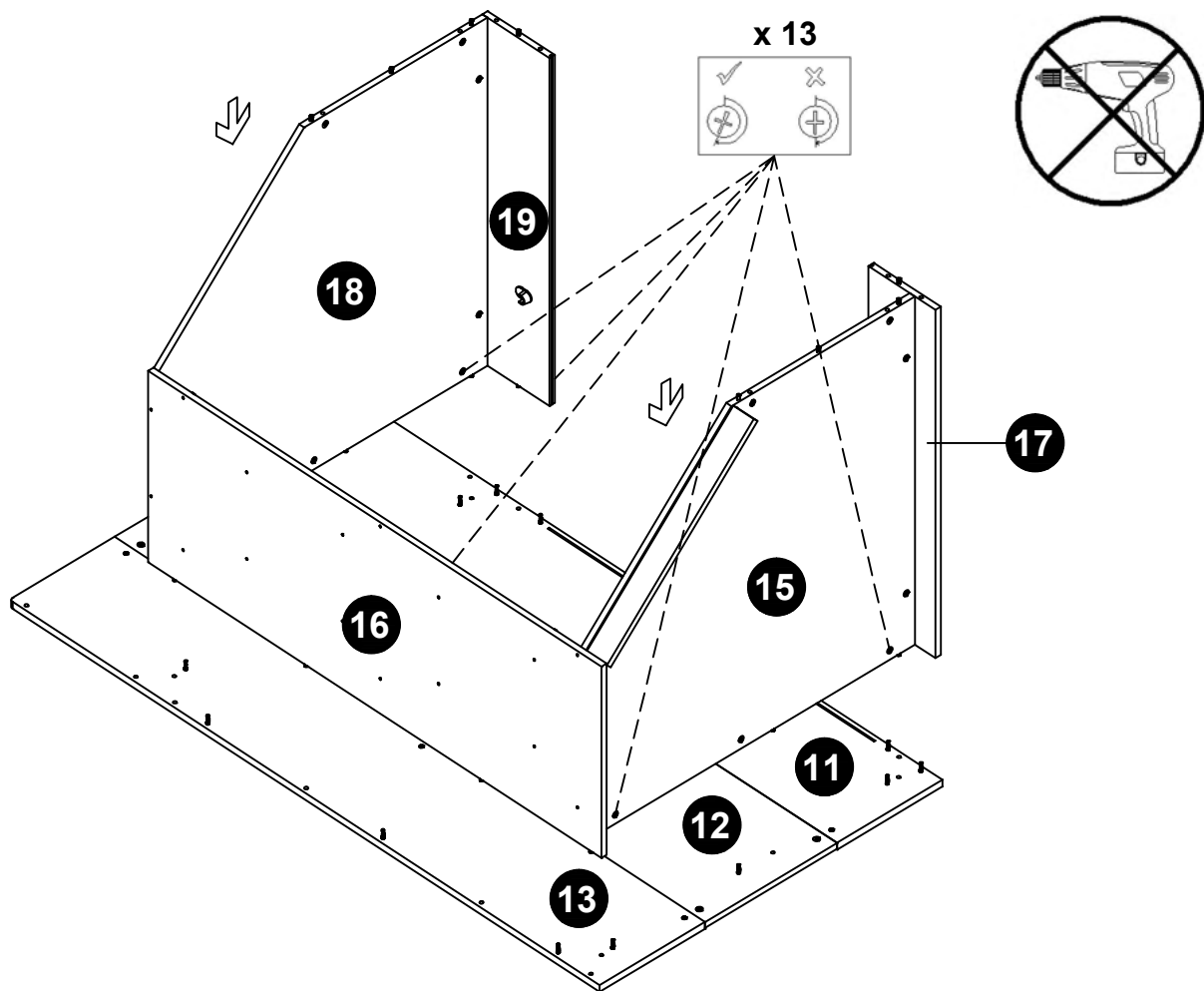

25

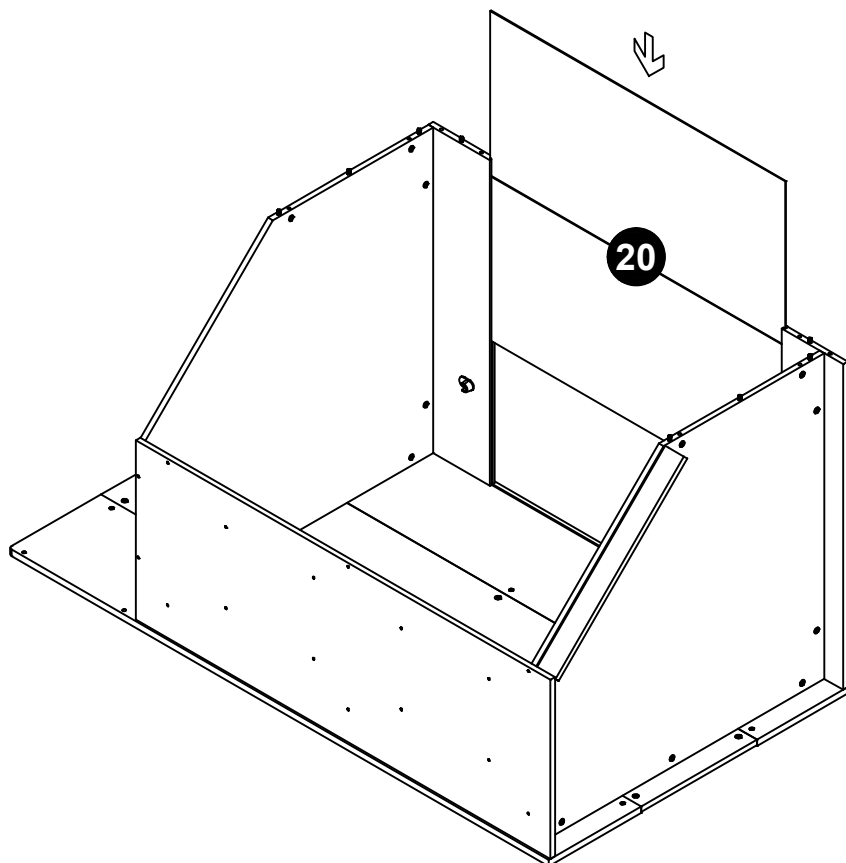

26

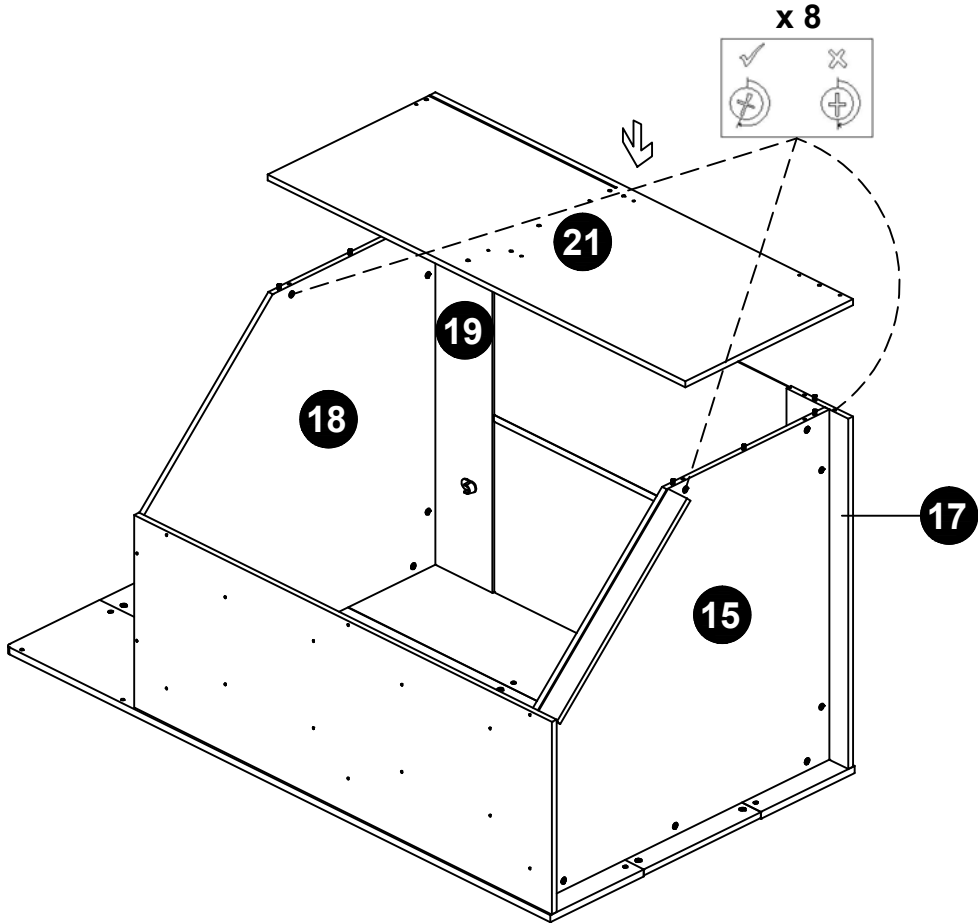

27



A x 7



T x 14

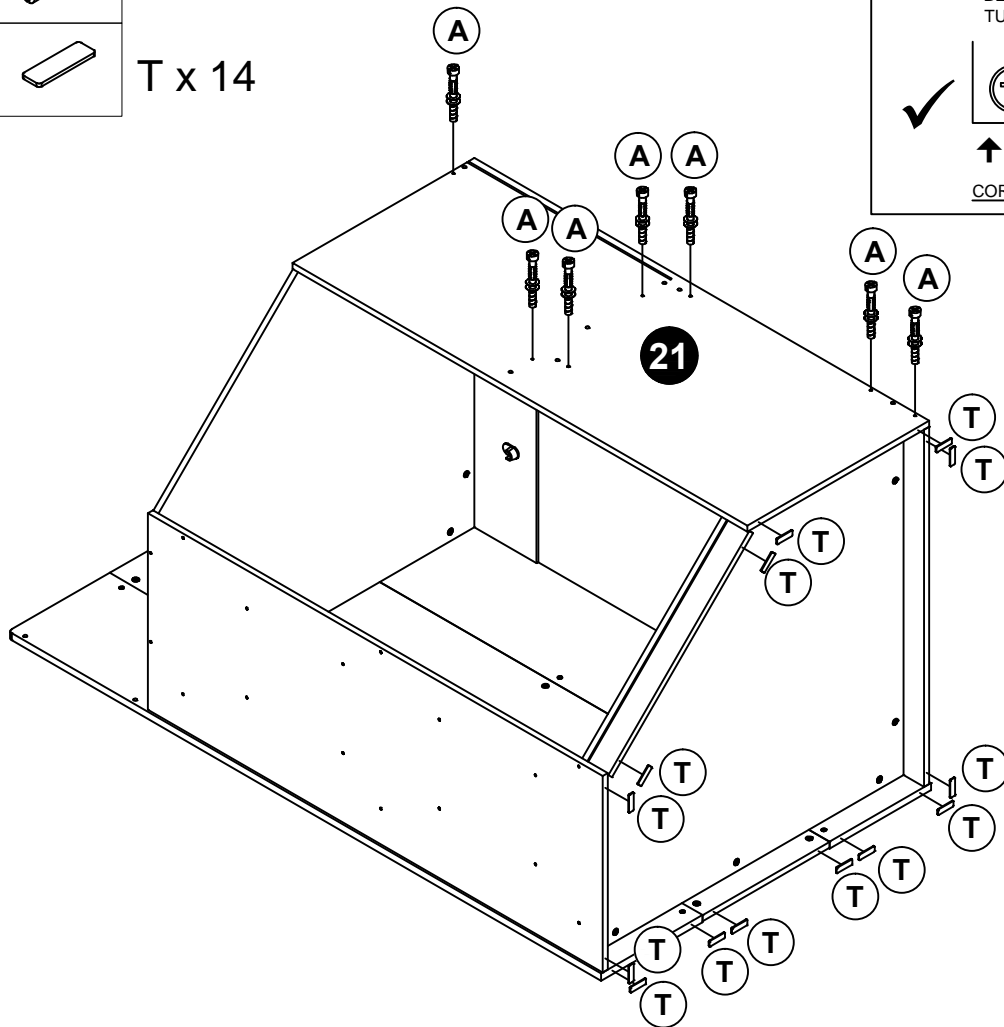

WHEN FITTING CAMS

ENSURE STARTING POSITION IS CORRECT BEFORE YOU INSERT CONNECTING BOLT TURN CLOCKWISE UNTIL SECURE

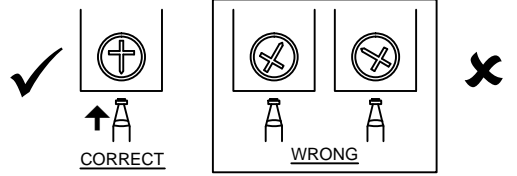

28

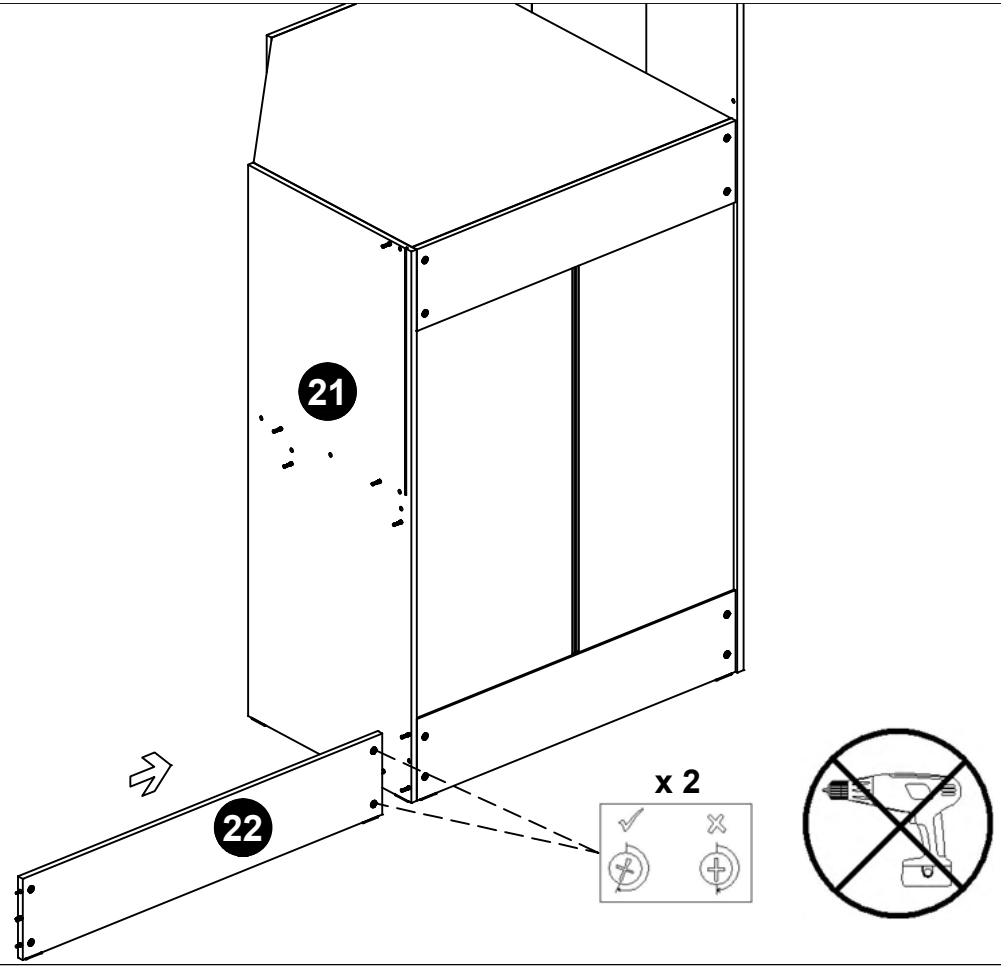

29

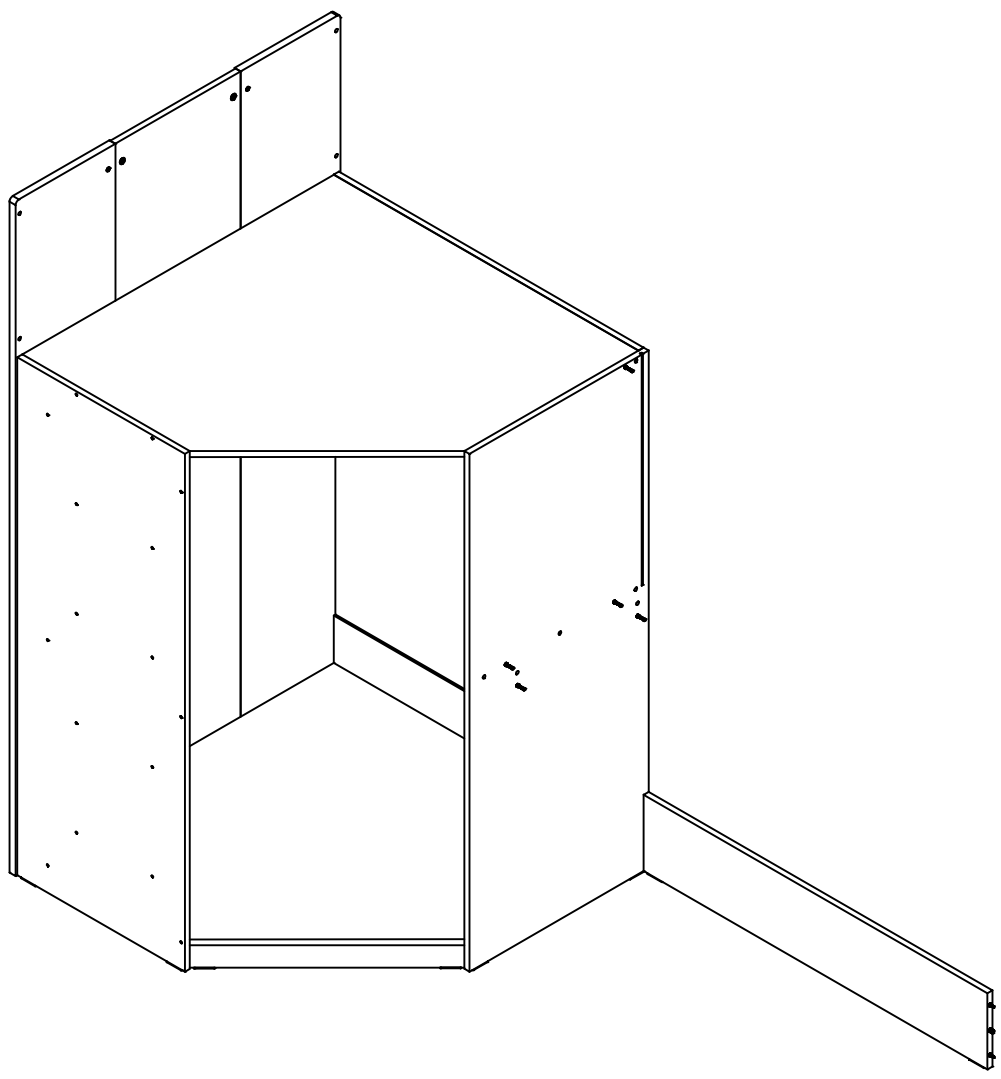

30

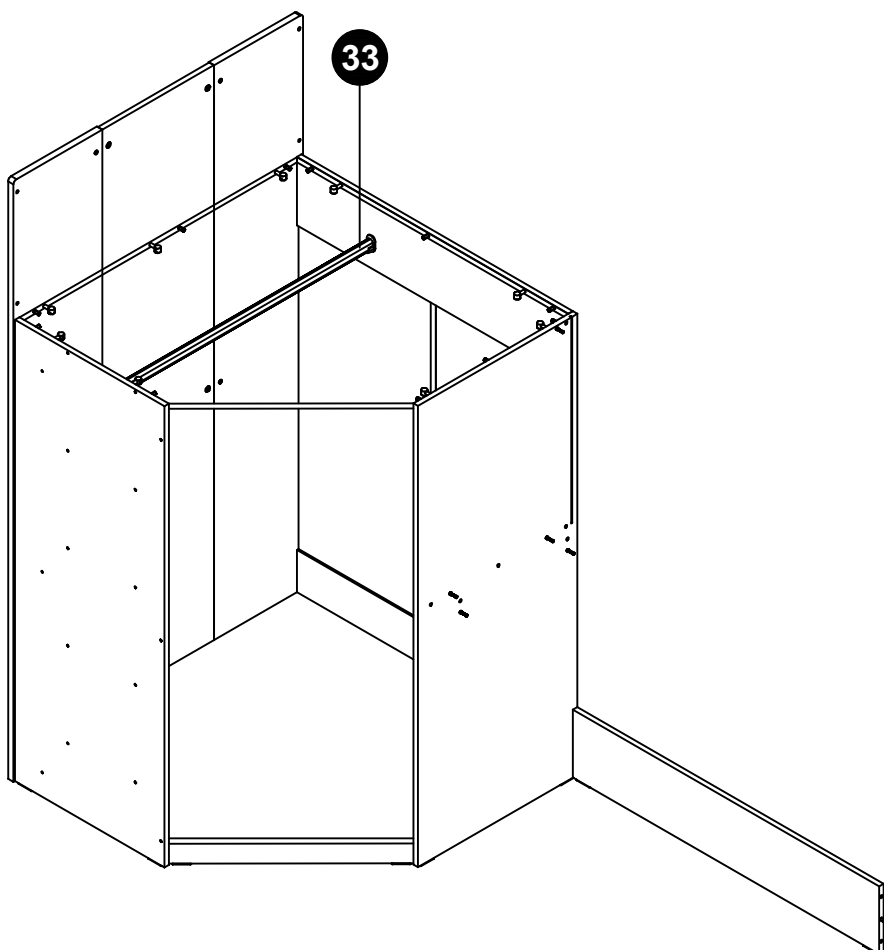
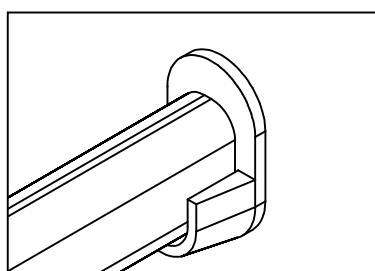
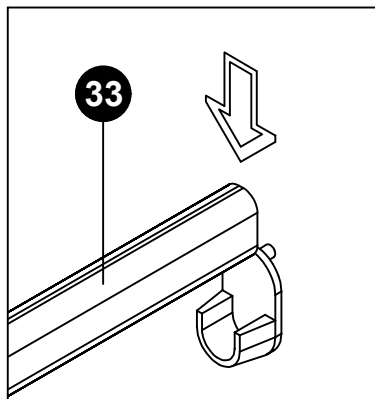

31

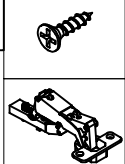

E x 12

L x 6

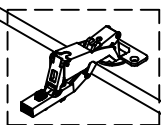
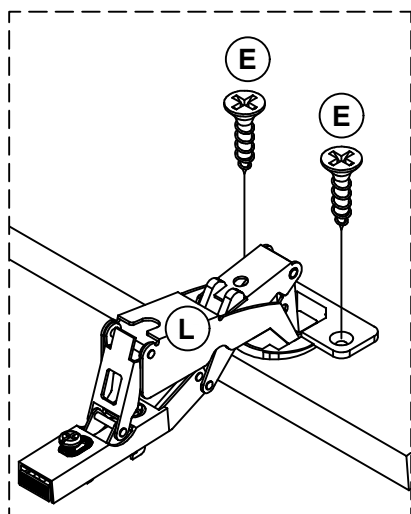
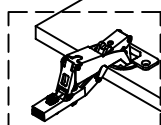

30 x 2

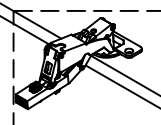

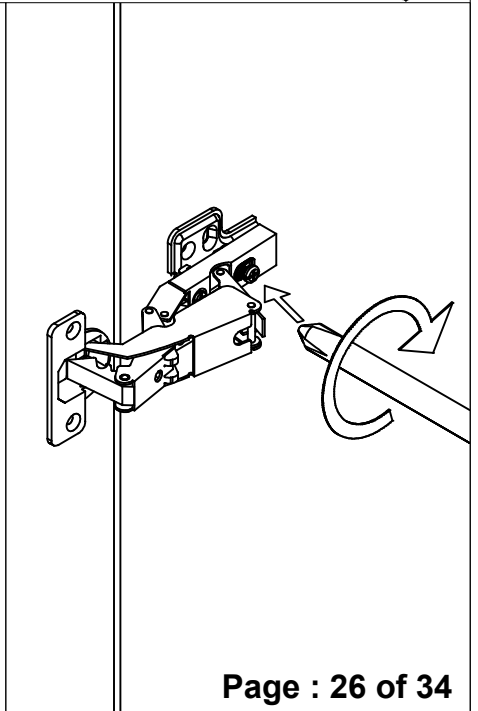
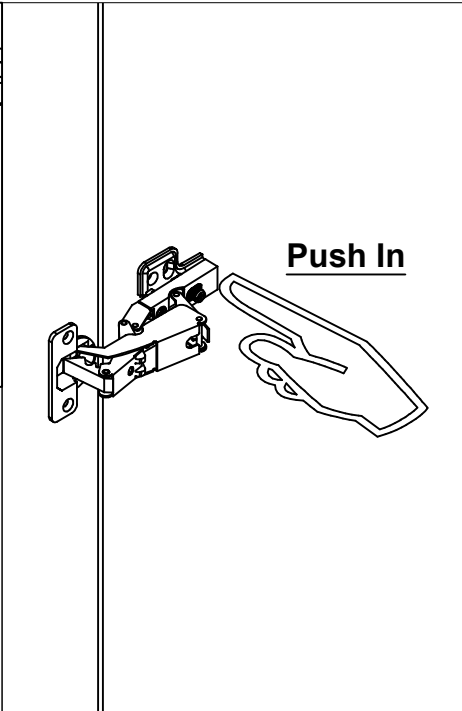
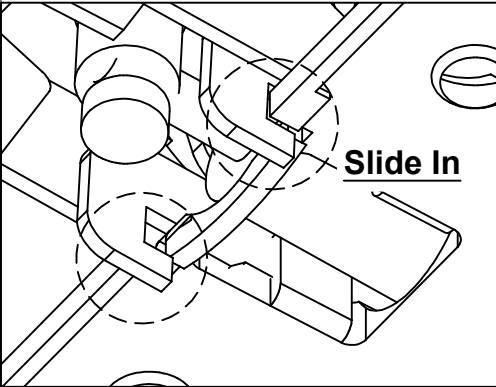
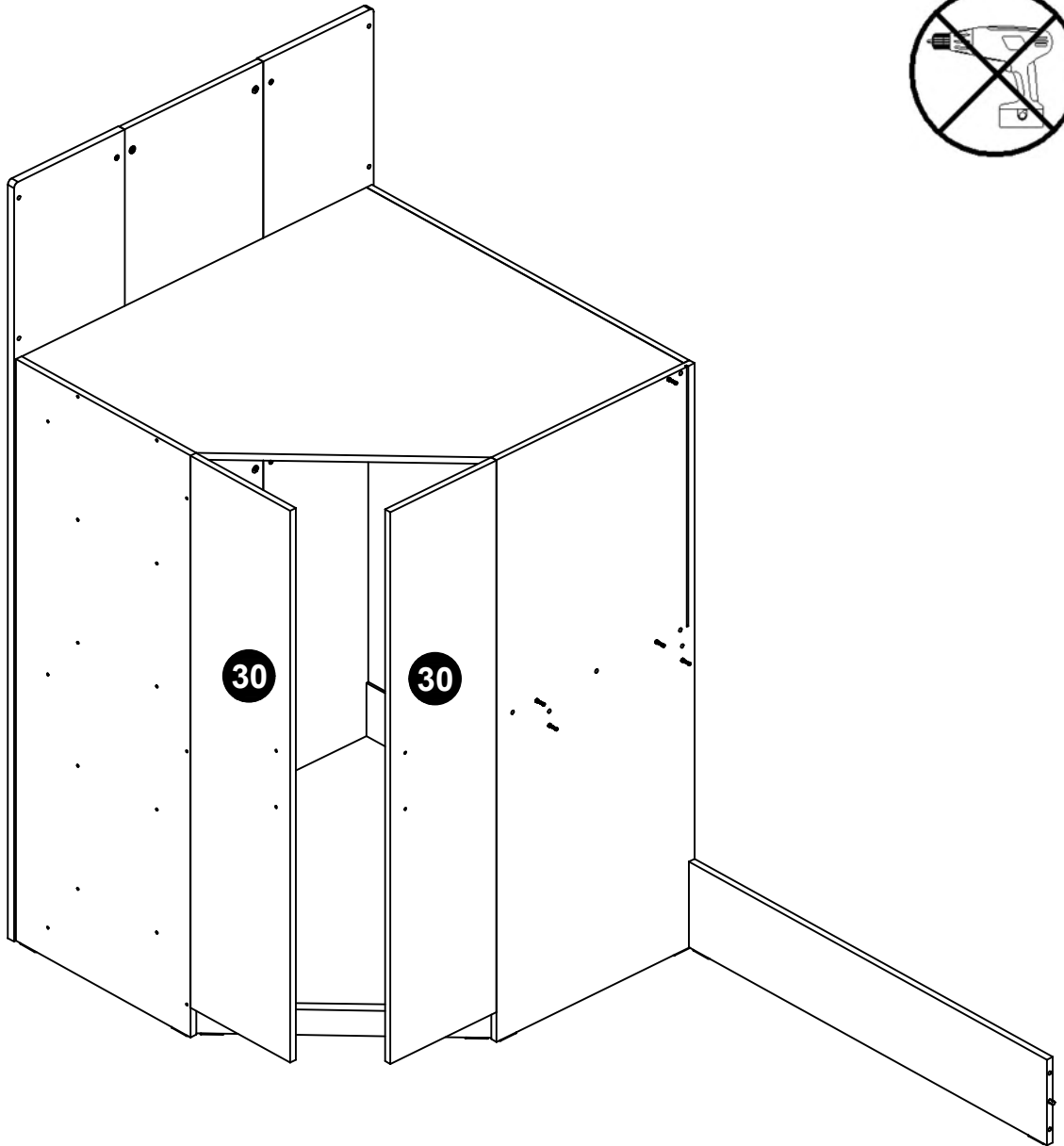

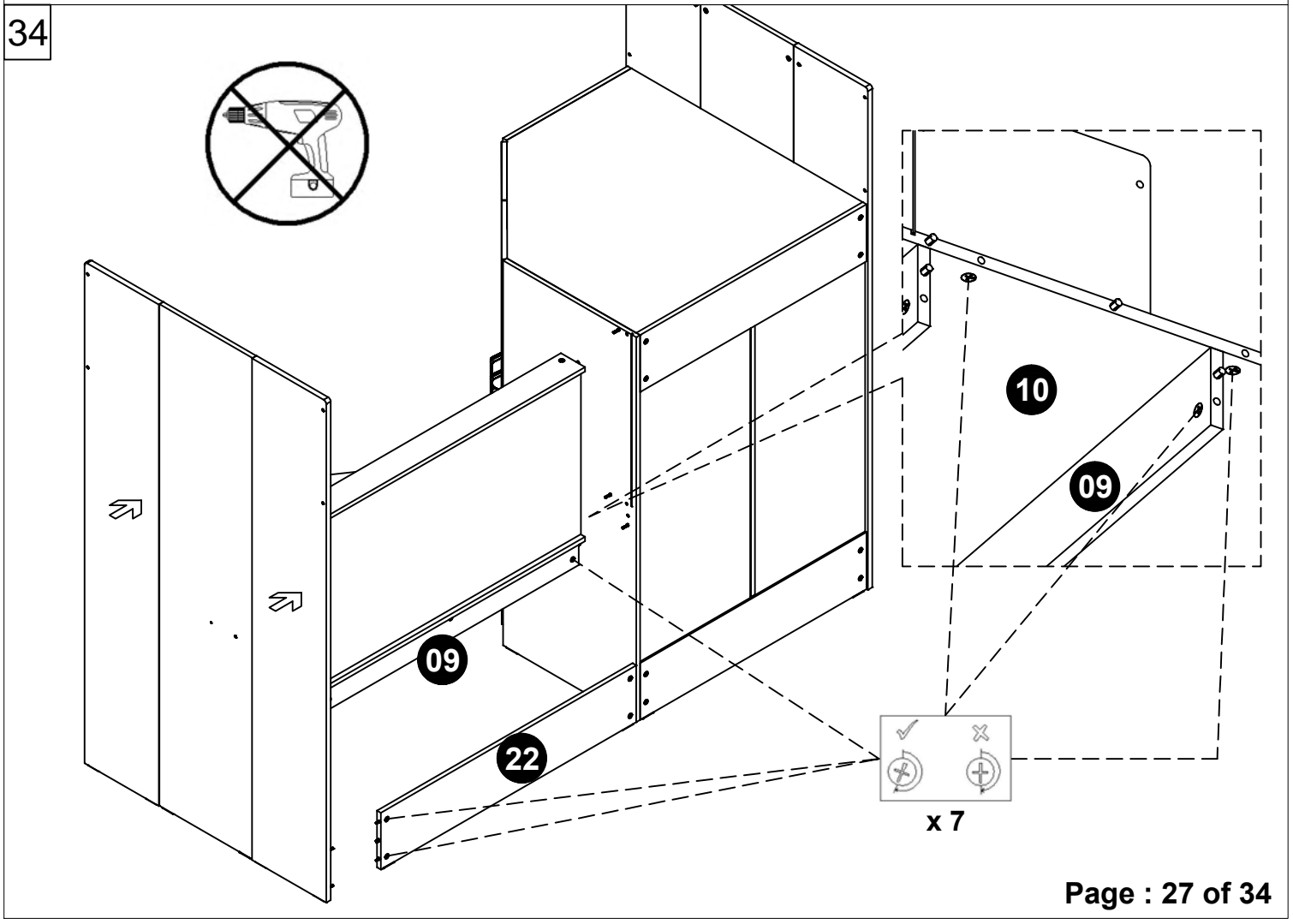
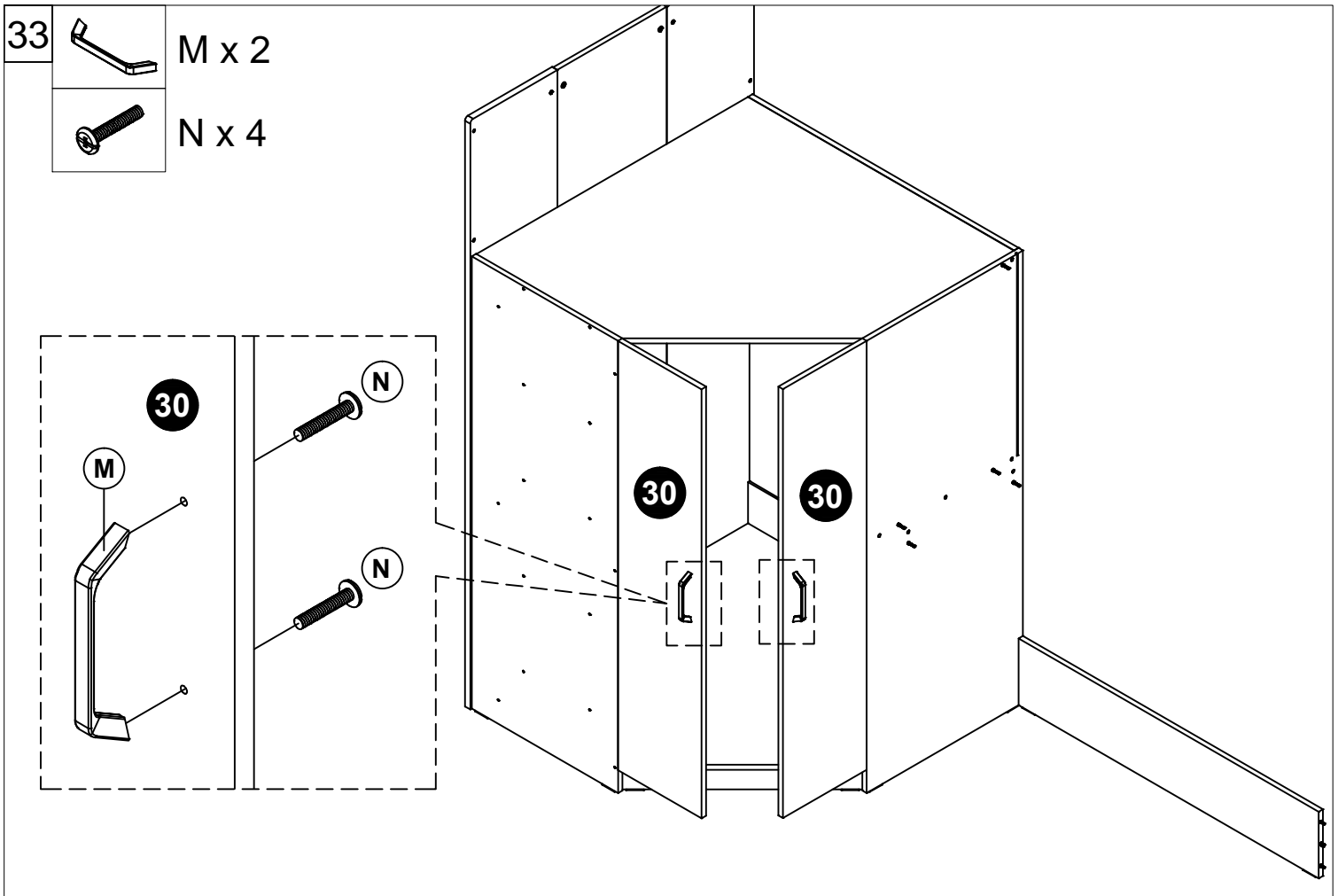

35



J x 10



R x 6



V x 2

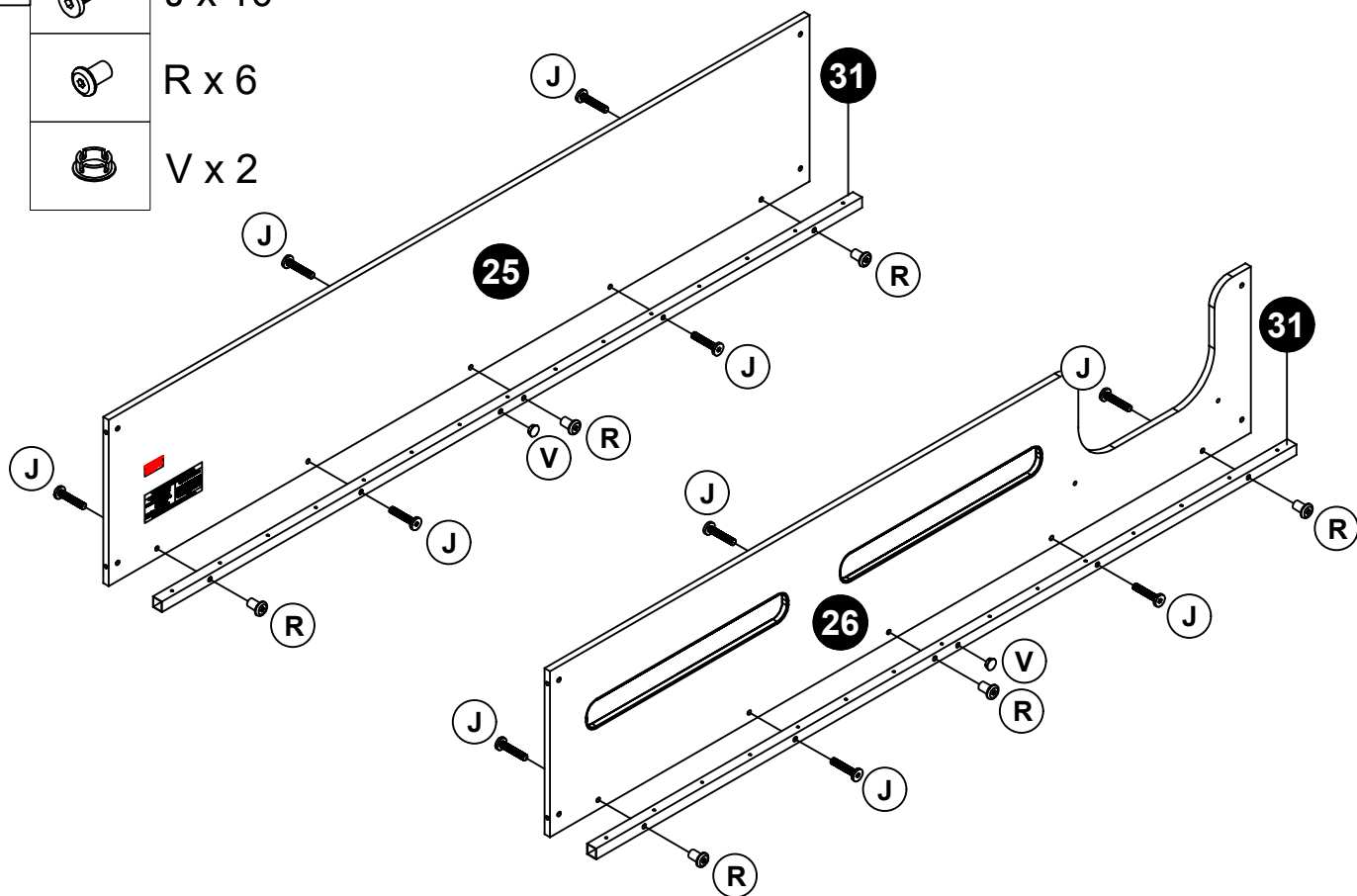

36



H x 4



Q x 4

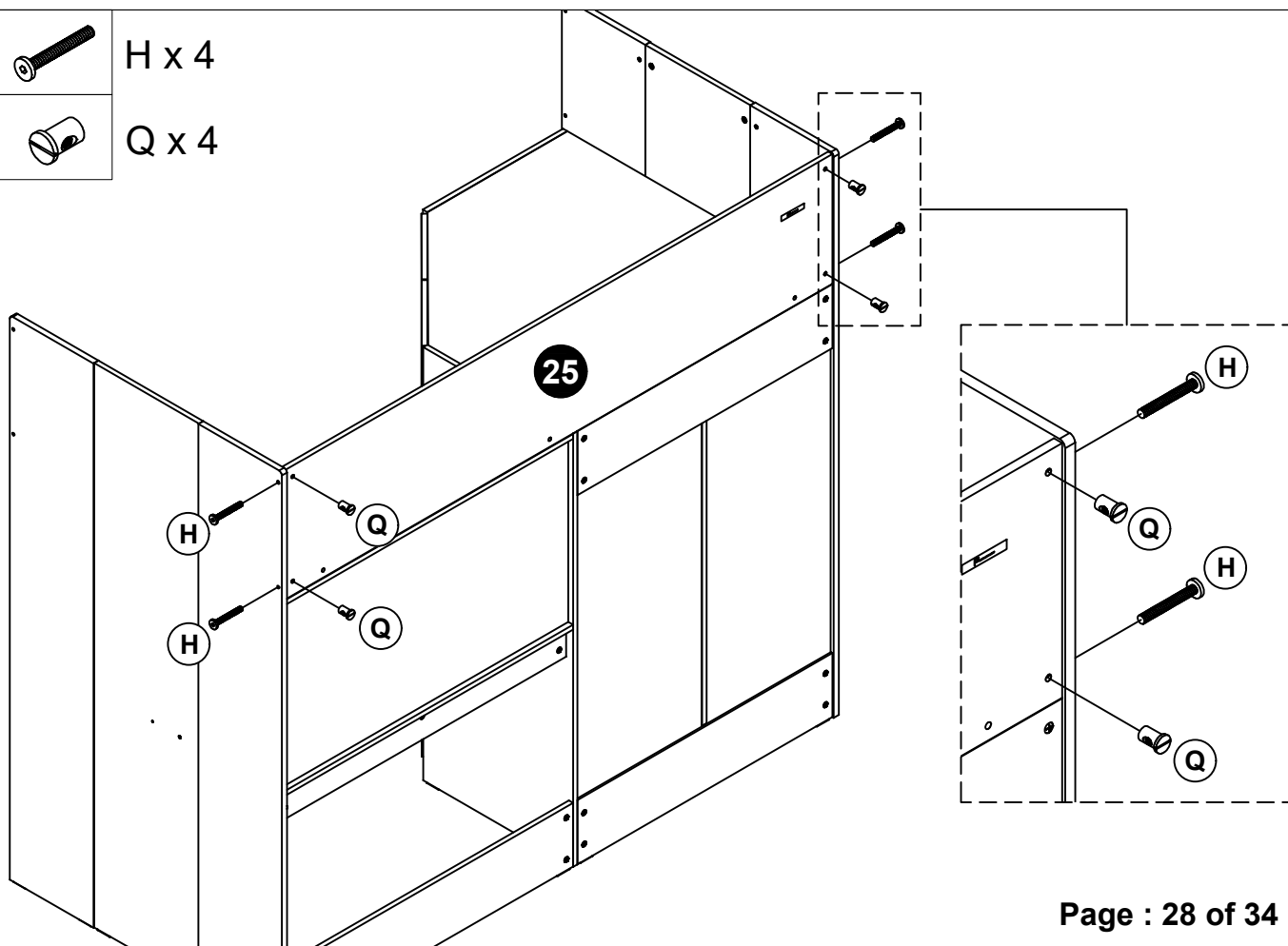

37



H x 4



Q x 4

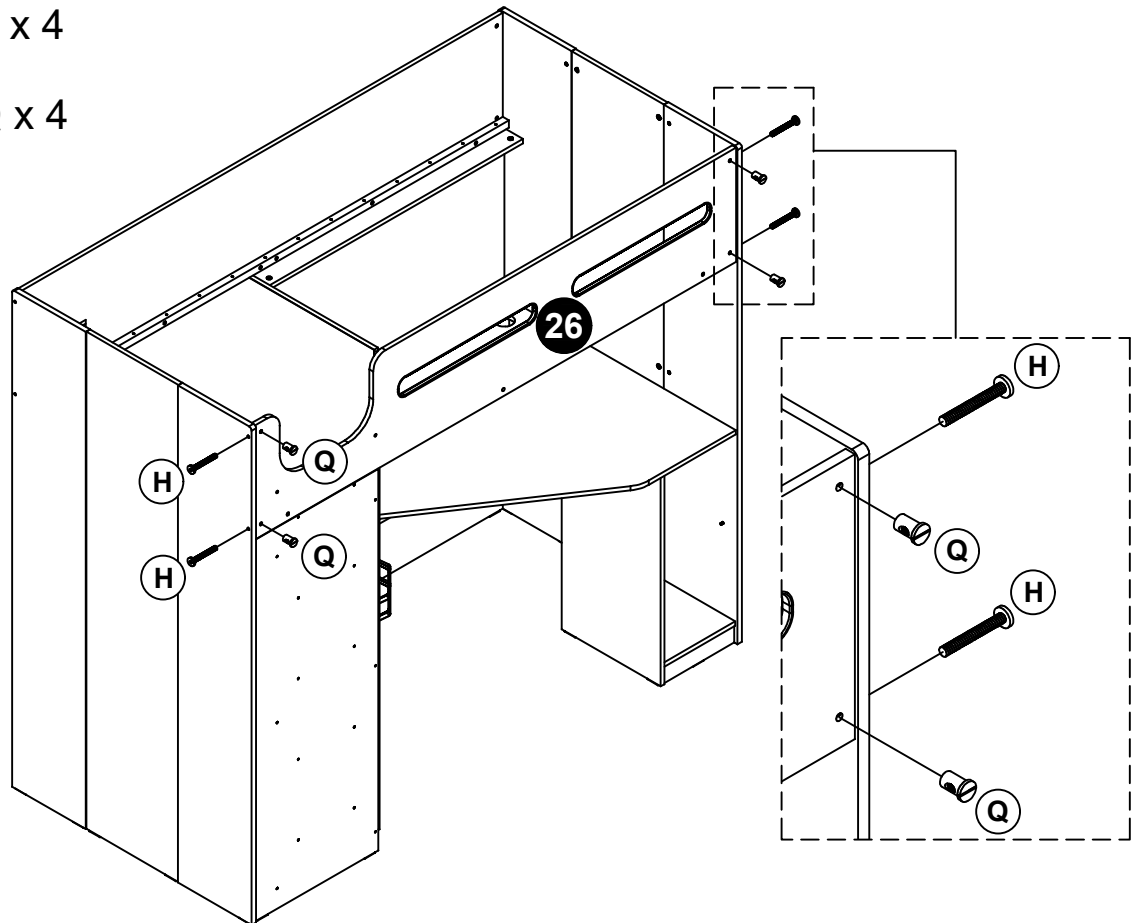

38



A x 10



B x 26



D x 20



G x 2

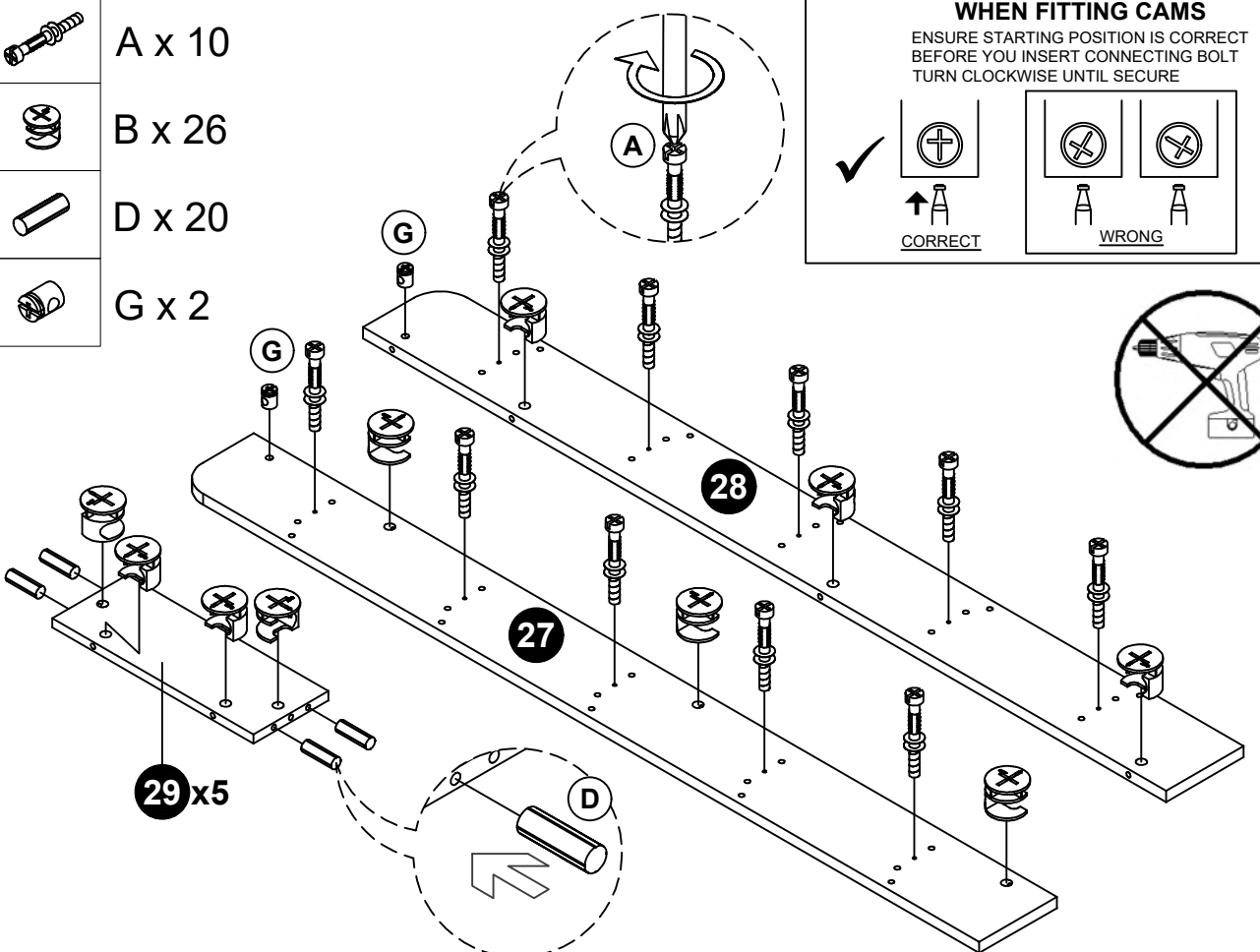

WHEN FITTING CAMS

ENSURE STARTING POSITION IS CORRECT
BEFORE YOU INSERT CONNECTING BOLT
TURN CLOCKWISE UNTIL SECURE

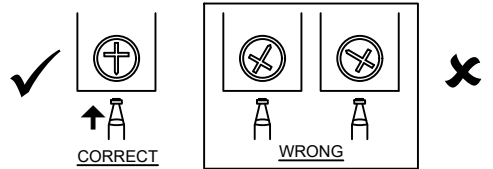

39

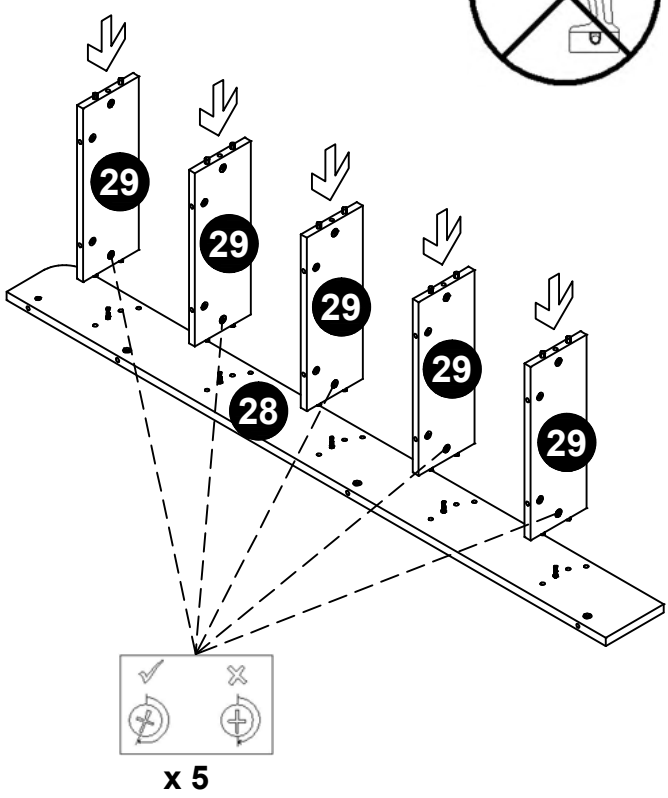

40

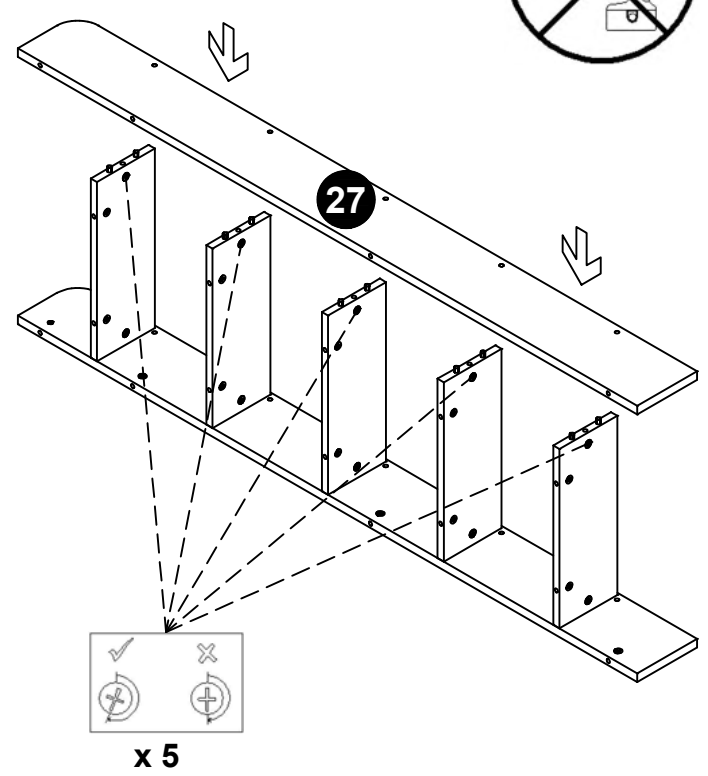

41



T x 4

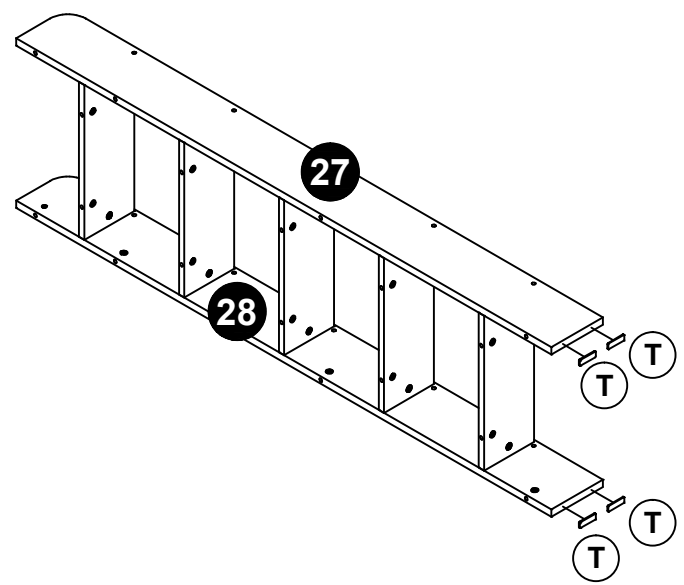

42



J x 10

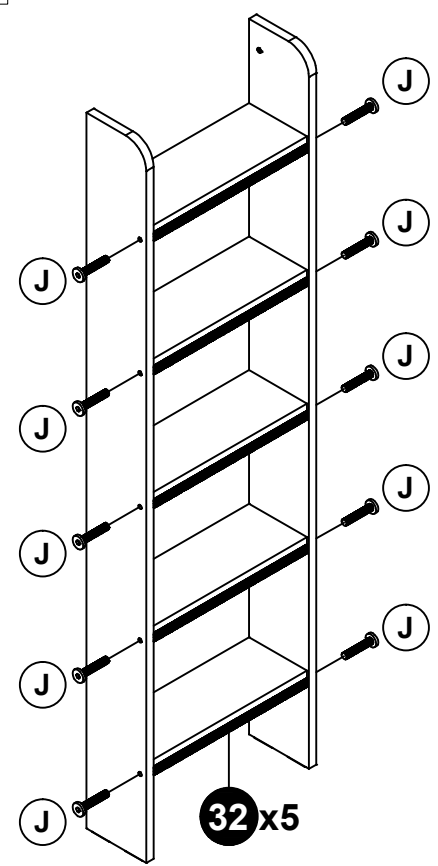

43



A x 16

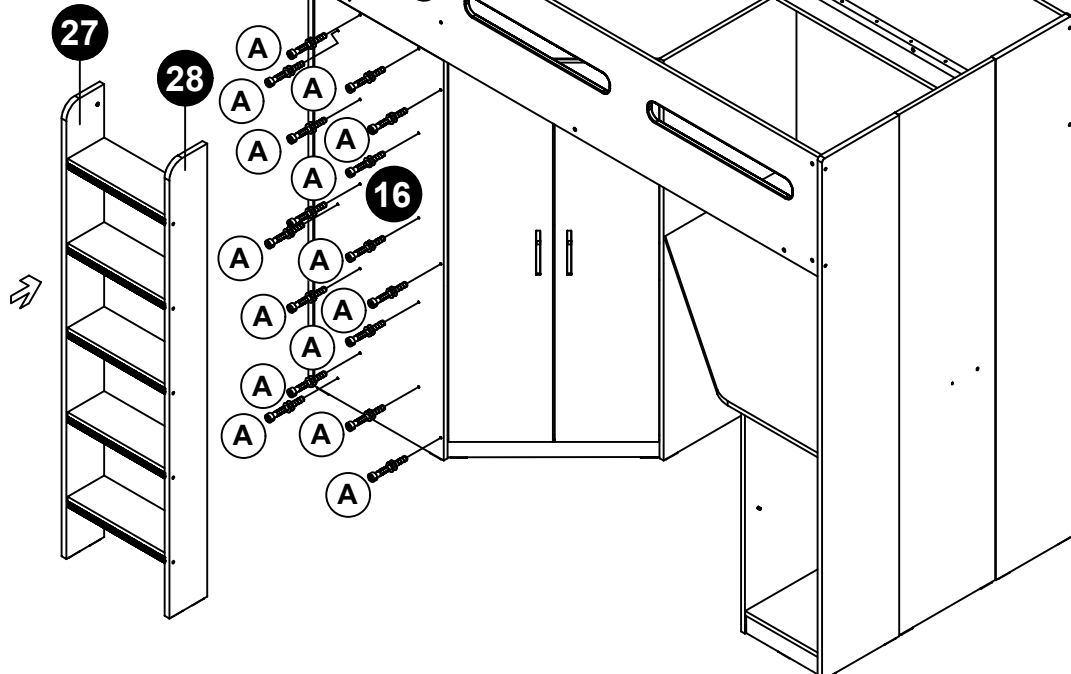

44

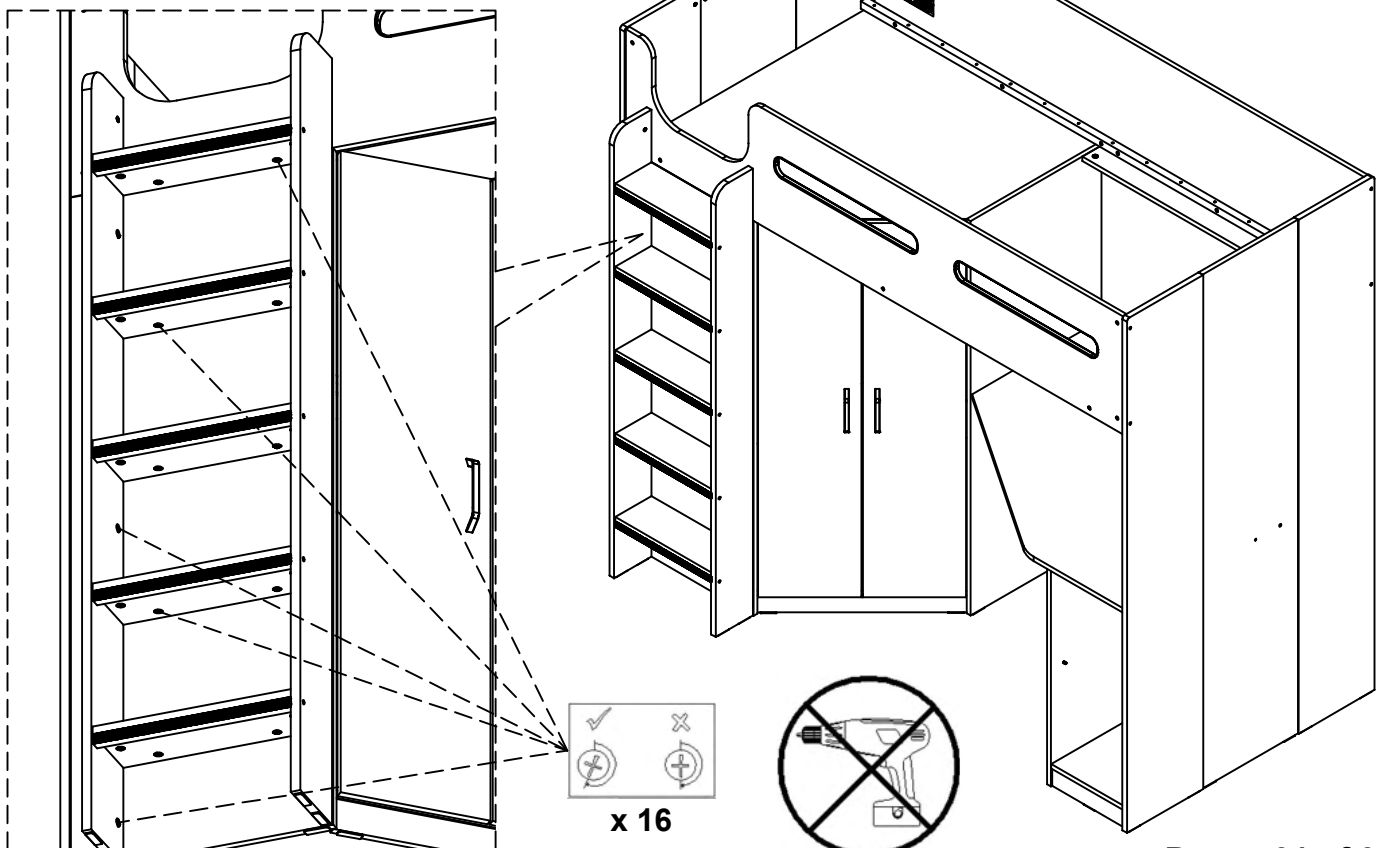

45



H x 2

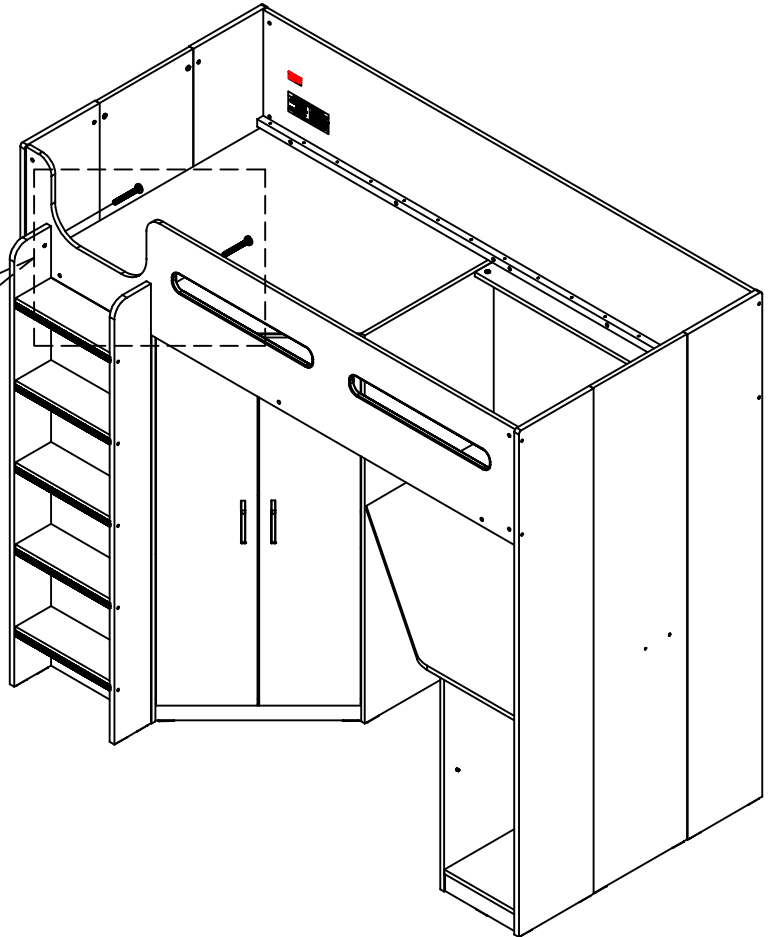
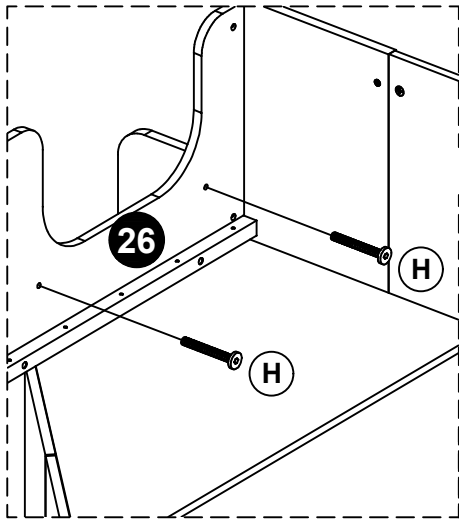

46



K x 30

LVL Slats x15

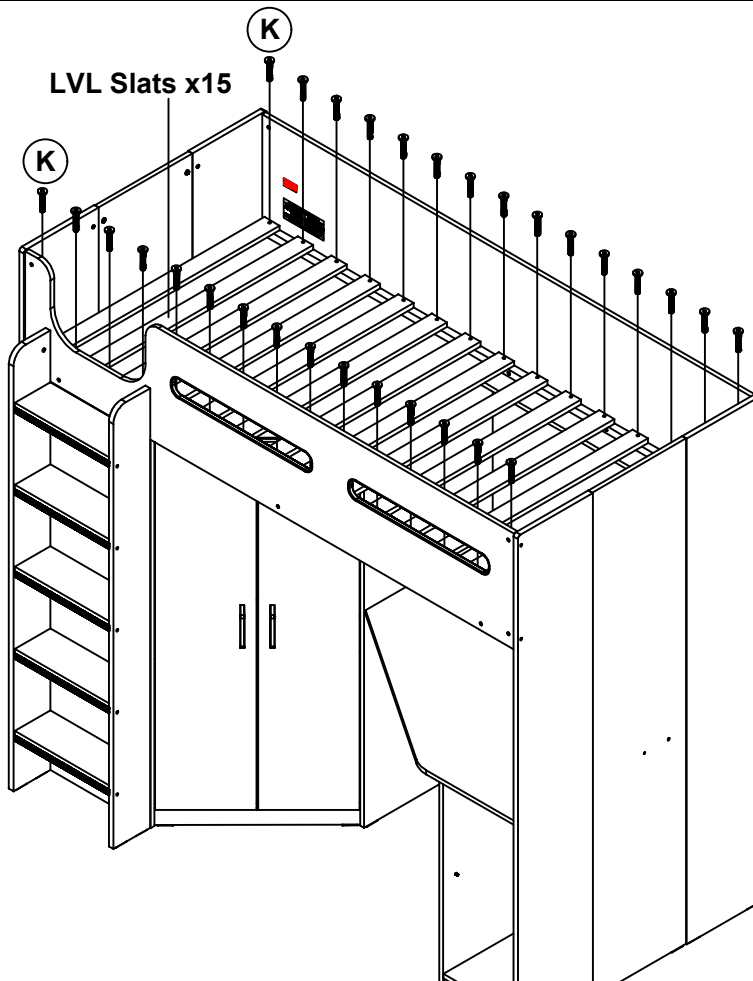

47



U x 3

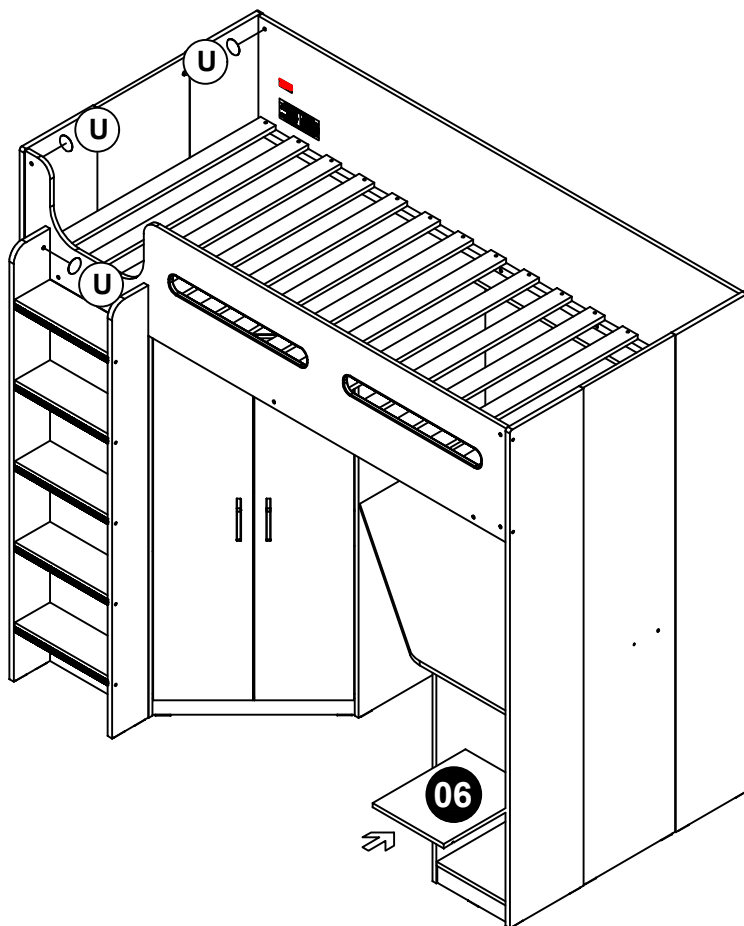

48



U x 3



F x 1

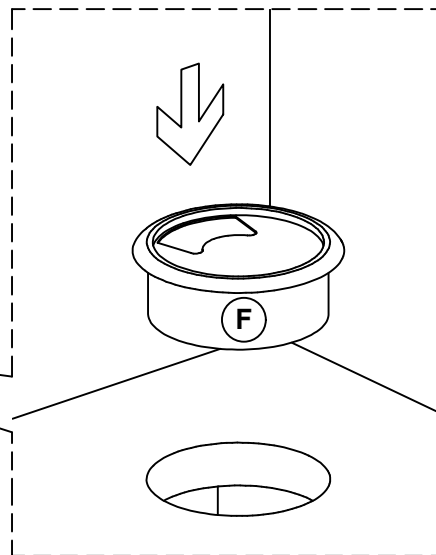
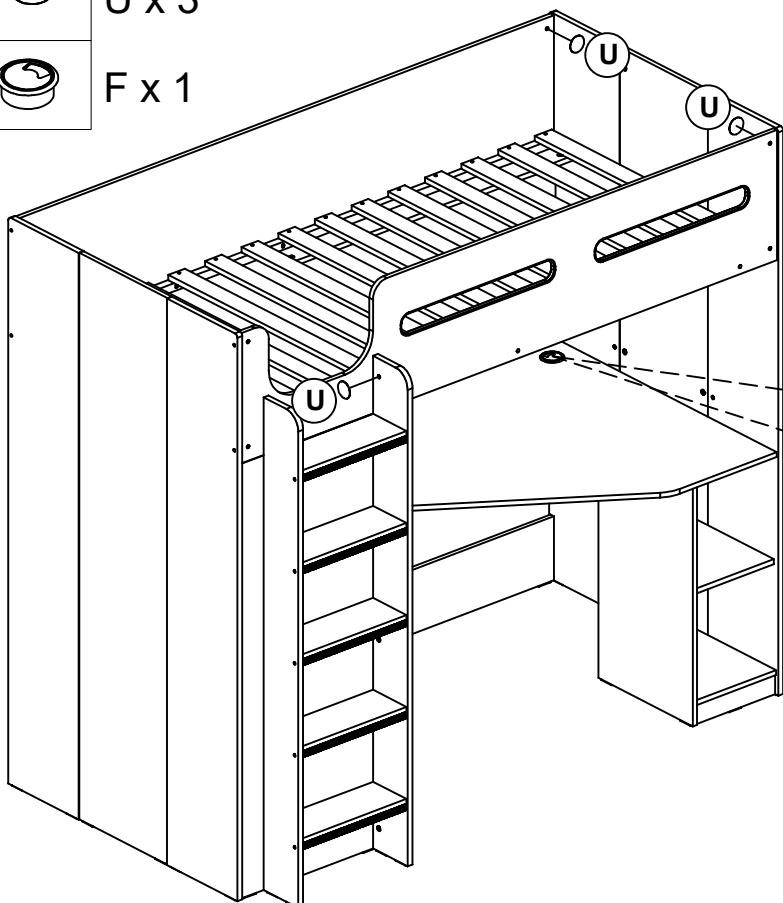

Please dispose of all packaging safely.

General Care & Maintenance

Wipe clean with a slightly damp cloth.
Avoid the use of all household cleaners and abrasives.

Periodically check all screw & fixings to ensure they are secure.

When moving your product, carefully lift into place. Never drag or push the product across the floor as this will cause damage to the joints. If the product is used on hard flooring, such as wood or laminated floor, you must place some protection under the legs to stop the product from moving. If this is not adhered to, it could result in failure to the product that will invalidate the warranty.

For more information on cleaning and product care visit:
<https://www.happybeds.co.uk/help-and-advice>

Notes

In the unlikely event that you have problems putting this product together or have damaged or missing parts, please contact us by visiting:
<https://www.happybeds.co.uk/customer-service>