



# Hit White Wooden High Sleeper

## Assembly Instructions

### Important before assembly:

Read these instructions carefully before assembling or using the product.

Please check the contents of the boxes before attempting to assemble this product. The instructions will have a checklist of parts and fittings.

Assemble the product as close to its intended final location/room as possible.

### Health & Safety:

This product or some parts of this product will be heavy. Please use an assistant when lifting.

Please keep small parts out of reach of children.

Always use on a level, even surface.

DO NOT jump on the product or any of its parts.

DO NOT use this product if any parts are missing, damaged or worn.

DO NOT use this product unless all fixings are secured.

**Further instructions are on the following pages.**

Please keep these instructions for future reference.



This product or some parts of this product will be heavy. Please use an assistant when lifting.



Never drag or push the pieces across a hard or stone floor as this will cause damage to the joints. Use a carpet or a rug for extra care.



If you have problems assembling or have damaged or missing pieces, please contact our customer services (details at the back of these instructions)



80-06501-1  
200x90 cm.  
Hit

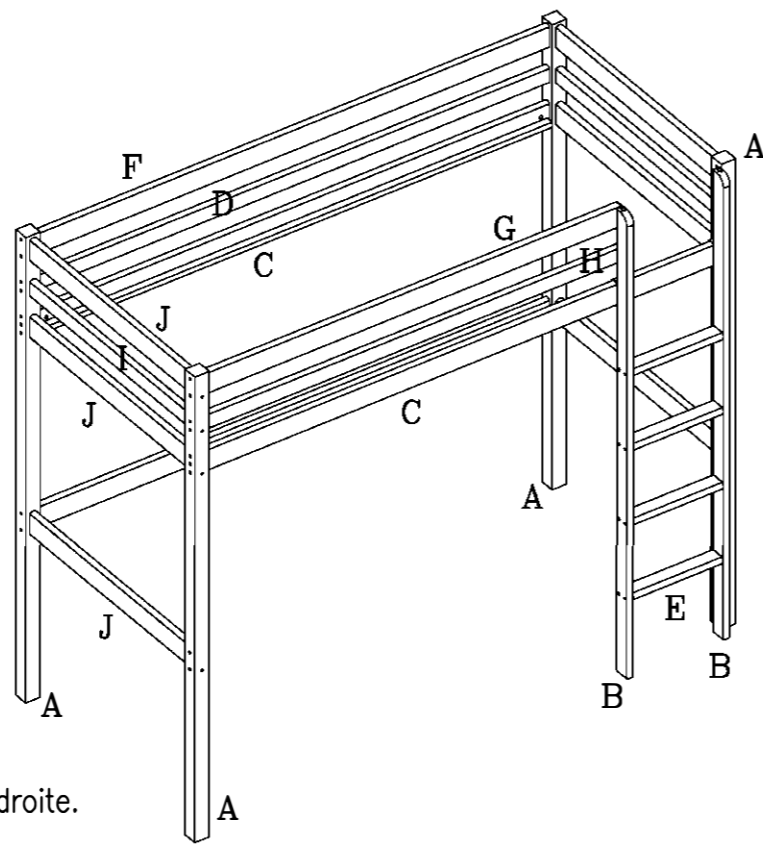

Sicherheitsanforderung: Norm EN747-1&EN747-2...nur mit THUKA-Rollrost Art.Nr. 666.090  
Safety requirements: Norm EN747-1&EN747-2...only with Thuka-Slats Art.No. 666.090  
Conforme aux exigences de sécurité en vigueur- Normes EN747-1&2...avec sommier THUKA réf. 666.090

- A) Befestigung eines Lattenrostes: auflegen und jede Latte mit Bohrung auf der Seitenleiste verschrauben. Vorteil: Lattenrost kann sich nicht mehr verschieben. Sicherheitsnorm EN747-1 & EN747-2 wird nur eingehalten, wenn die Latten in einen Abstand von 60-75 mm angebracht werden. Abstand zwischen Roll-Lattenrost und Stirnseite: Min. 12mm - Max 25mm.!
- B) Die Oberseite der Matratze darf nicht über die Markierung hinausgehen (muss mindestens 160 mm unterhalb der Oberkante der Absturzicherung liegen).
- C) Bei Neuaufstellung Kindern Hilfestellung bieten.
- D) **Achten Sie bei der Benutzung des oberen Bettes durch Kleinkinder (unter 6 Jahren) auf der Gefahr des Herunterfallens!**
- E) Darauf achten, dass Kinder, Kleidung ohne Schnüre oder Bänder tragen.
- F) Gerät regelmässig inspizieren: Schraubverbindungen g.g.f. nachziehen.

- A) Fastening the bed slats: Screw the slats to the two side rails. Secure ALL slats with a screw at each end. In order to comply with current safety regulations (EN747-1 & EN747-2), each bed slat must be spaced evenly, with a gap of between 60 and 75mm. The distance between the bed ends and the end slat must be min. 12mm - max. 25mm.
- B) The top surface of the mattress must not be higher than the level indicated; ensure min. 160 mm between the mattress top surface and the top edge of the safety rails.
- C) After assembly, instruct children how to use the bed safely.
- D) **Be aware of the danger of young children (under 6) falling from the upper bunk.**
- E) To avoid snagging, ensure that clothing is free of loose items as laces, tapes etc.
- F) Regularly check and, if necessary, tighten all fittings.

- A) Fixation du sommier: vissez toutes les lattes, des deux côtés sur les supports de longerons. Afin de répondre aux normes de sécurité (EN747-1 & EN747-2), les lattes du sommier doivent être espacées de 60 à 75 mm. La distance entre les dernières lattes et la tête-et-pied de lit, doit être de min. 12 et max. 25 mm.
- B) Le dessus du matelas ne doit pas dépasser le niveau indiqué sur les lattes de protection (doit être au moins 160 mm en dessous du niveau supérieur de la latte).
- C) Après assemblage, expliquez à l'enfant comment utiliser le lit.
- D) **Le couchage en hauteur ne convient pas à des enfant de moins de six ans**
- E) Evitez que les vêtements de l'enfant ne comportent de lacet ou de ruban.
- F) Vérifiez régulièrement les fixations et si nécessaire reserrez.

**CLEANING:**

**LACQUERED:**  
Wooden, lacquered and painted as well as laminated surfaces should be wiped over with a cloth and a mild soap.

**OIL:**  
Oiled surfaces can be cleaned with soapy water, e.g. brown soap. Wipe with a clean cloth.

To maintain the natural life in the furniture which is provided by the oil treatment, we recommend an oil aftercare of the furniture 1-2 times a year. The colourless natural oil for maintenance of oil-treated furniture is available at your local furniture store.

**Important:**  
Please keep these instructions in a safe place for future use. (Repaire, maintenance, second hand sale etc).

Packed in a re-cycling cardboard box.

In the unlikely event that this product has missing or damaged parts, please call: 0113 234 9444 or fax:0045 9772 3233 or e-mail: service@thuka.dk to obtain spares.

**Nettoyage:**

**LAQUÉ:**  
Les surfaces bois, laqués, peintes et laminés peuvent être séchées avec un chiffon et un savon doux.

**HUILE:**  
Des surfaces huilés peuvent être nettoyées avec l'eau savonneuse, par ex. savon mou, et essuyées vec un chiffon pur.

Pour maintenir la vie naturelle dans la meuble, que l'huile donne, nous recommandons un traitement complémentaire d'huile 1-2 fois par an. L'huile naturelle sans couleurs pour maintenance des meubles est peut être achetée à votre magasin d'ameublement local.

**Important:**  
Veuillez garder ces instructions pour l'usage future. (Réparations, maintenance, revente ect).

Emballé dans une boîte de carton réusable.

Au cas improbable des manques ou des marchandises gâtées veuillez téléphoner: 0113 234 9444 ou fax:0045 9772 3233 ou e-mail: service@thuka.dk pour obtenir des remplacements.

**Reinigung:**

**Lackierte Möbel:**  
Lackierte Holzoberflächen können mit einem sauberen Lappen und mildes Seifenwasser gereinigt werden.

**Geölte Möbel:**  
Geölte Holzoberflächen können mit einem sauberen Lappen und Seifenwasser, z.B. Schmierseife, gereinigt werden. Um das natürliche Aussehen des Holzes zu behalten, ist eine Öl-Nachbehandlung vom Möbelstück 1 bis 2 Mal pro Jahr empfehlenswert. Das farblose Öl, für die Nachbehandlung der Möbel, kann in Ihrem Möbelgeschäft gekauft werden.

**Wichtig:**  
O.g. Erhaltungsanleitung bitte für die Zukunft bewahren.

Das Möbel wird in umweltfreundlicher Recyclingpappe-Verpackung geliefert.

Sollte das Produkt, wider Erwartung, mangelhaft oder beschädigt sein, setzen Sie sich bitte in Verbindung mit uns für Ersatzteile, auf Fax Nr: 0045 9772 3233 oder Email: service@thuka.dk.

Thuka Furniture A/S  
(Part of the Flexa group)  
Industrivej 2, postboks 209  
Dk-7900 Nykøbing M.

- ! Ladder can be positioned left or right
- ! Die Leiter ist spiegelverkehrt montierbar
- ! L'échelle peut être positionnée à gauche ou à droite.

<p>Before assembling this product, please ensure that all the components supplied comply with the list on this page. All Screw-type fittings can be tightened with this tool.</p>			<p>Avant de commencer l'assemblage, veuillez contrôler si tous les objets indiqués sont présents. Tous les vis peuvent être serrés par cet outil.</p>			<p>Bevor Sie mit dem Aufbau beginnen, kontrollieren Sie ob alle auf der Zeichnung angegebenen Teile vorhanden sind. Bitte verwenden Sie zur Montage einen Kreuzschraubenzieher und den beiliegenden Innensechskantschlüssel.</p>			<p>Ware-nr. Part no. Réf No</p>	<p>Stck. Qty. Qté.</p>	<p>12-02603451-1 4 stck/pcs.</p>	
<p>Siehe Bild-nr. See picture no. Image no</p>			<p>Mass Dim. Dim.</p>			<p>E 345x60x26</p>						
<p>12-05517921-1 4 stck/pcs</p> <p>A 1792x55x55</p>	<p>12-02617811-1 2 stck/pcs</p> <p>B 1781x65x26</p>	<p>1305-19671-1 2 stck/pcs.</p> <p>C 1967x89x26</p>	<p>12-02619672-1 1 stck/pcs.</p> <p>D 1967x65x26</p>	<p>12-02615961-1 1 stck/pcs.</p> <p>E 1596x89x26</p>	<p>12-02615962-1 1 stck/pcs.</p> <p>F 1596x65x26</p>	<p>12-02608732-1 2 stck/pcs</p> <p>G 873x65x26</p>	<p>12-02608731-1 6 stck/pcs</p> <p>H 873x89x26</p>					
<p>3913-08100 4 stck/pcs.</p> <p>Z1 M8x100 mm.</p>	<p>3909-70100 24 stck/pcs.</p> <p>Z2 ø7x100 mm.</p>	<p>3909-70060 10 stck/pcs.</p> <p>Z3 ø7x60 mm.</p>	<p>3930-10050 40 stck/pcs.</p> <p>Z4 ø10x50 mm.</p>	<p>3901-30015 2 stck/pcs.</p> <p>Z5 ø3x15 mm.</p>	<p>3901-40030 41 stck/pcs.</p> <p>Z6 ø4x30 mm.</p>	<p>3907-63022 3 stck/pcs.</p> <p>Z7 ø6.3*22 mm.</p>						
<p>3922-08018 4 stck/pcs.</p> <p>Z8 M8xø12x18 mm.</p>	<p>4008-021 3 stck/pcs.</p> <p>Z9 20x20x16 mm.</p>	<p>3938-000081-1 8 stck/pcs.</p> <p>Z10 ø8 mm.</p>	<p>3938-00010-1 32 stck/pcs</p> <p>Z11 ø10 mm.</p>	<p>4007-014 2 stck/pcs.</p> <p>Z12 26,5 mm.</p>	<p>4008-022 2 stck/pcs.</p> <p>Z13 70x40.5x20 mm.</p>	<p>4033-005 1 stck/pcs.</p> <p>Z14 5 mm.</p>						

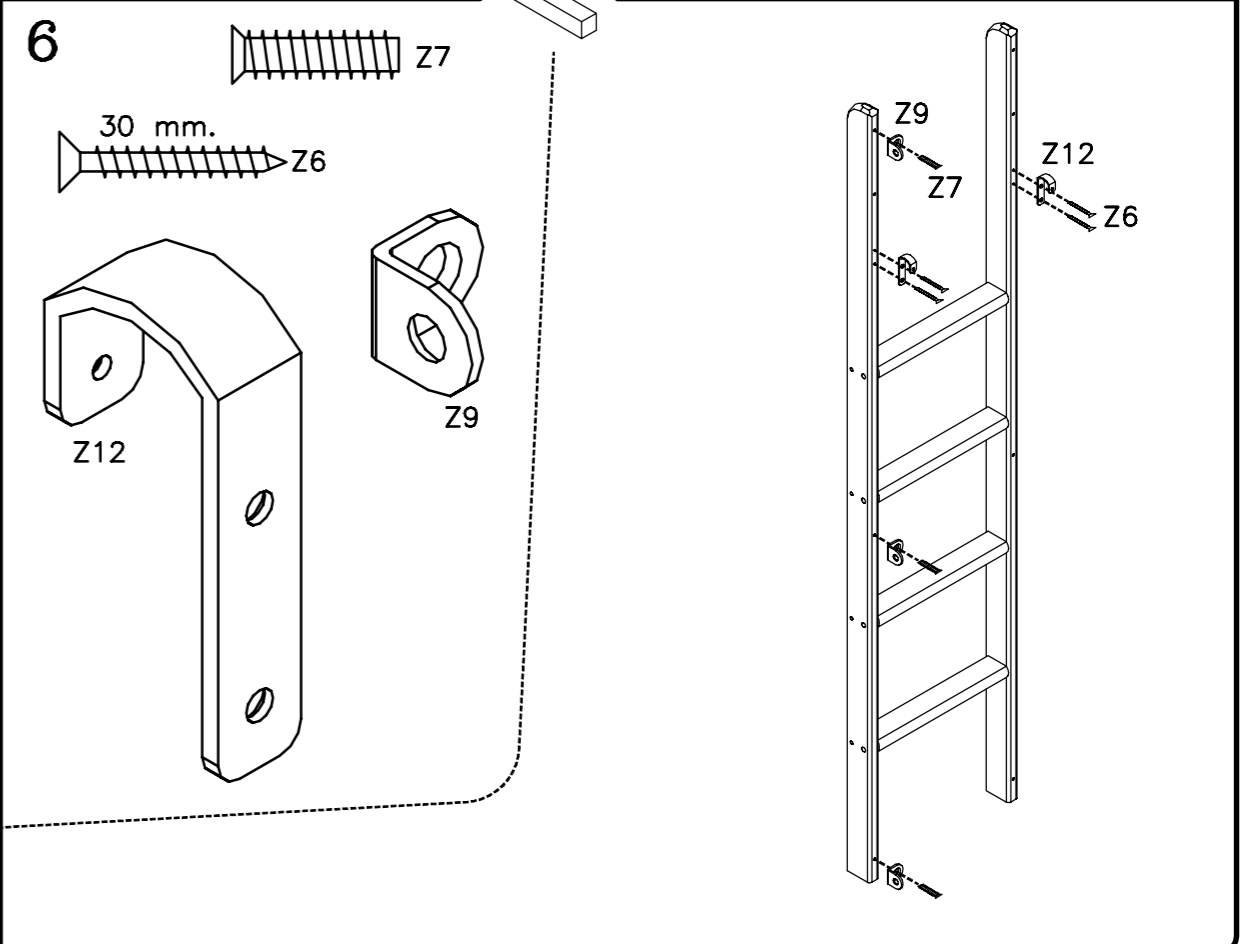
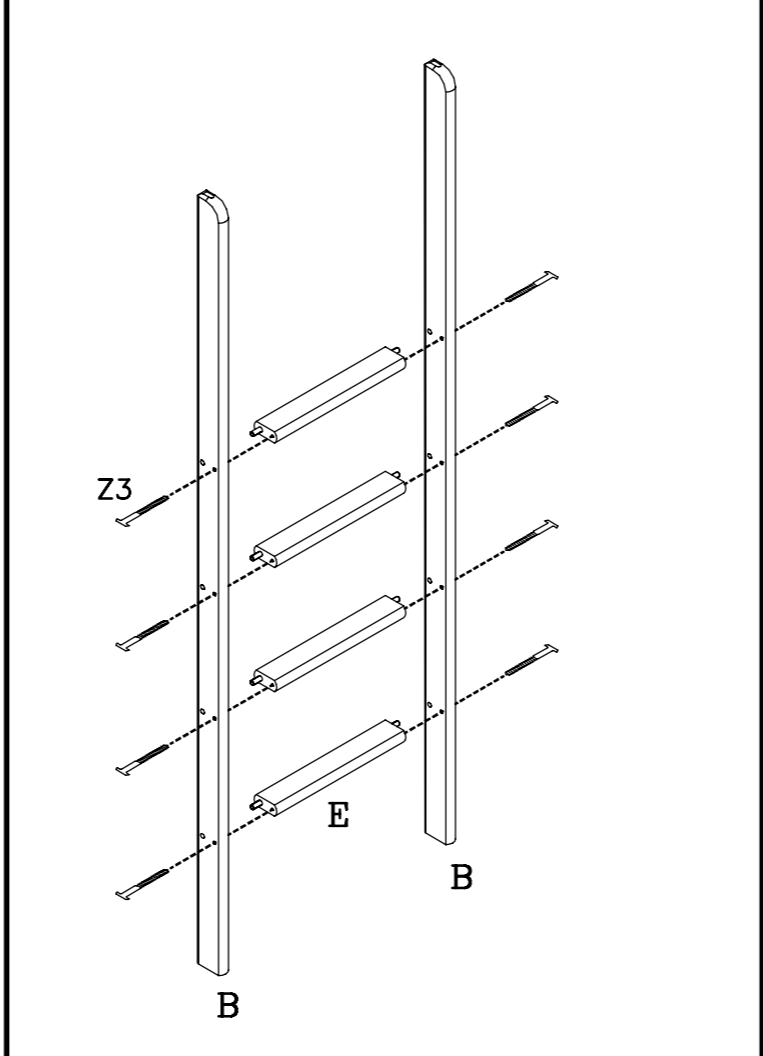
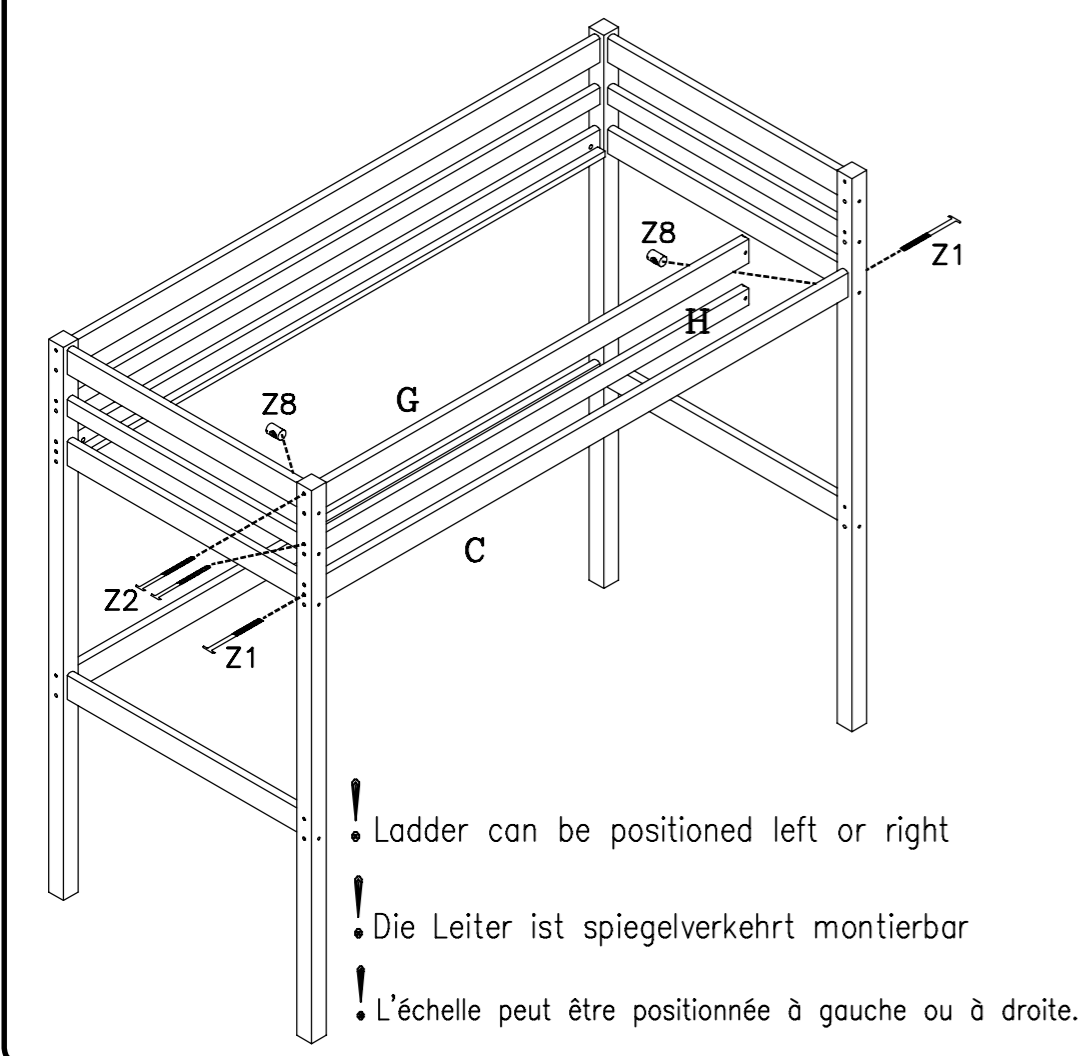
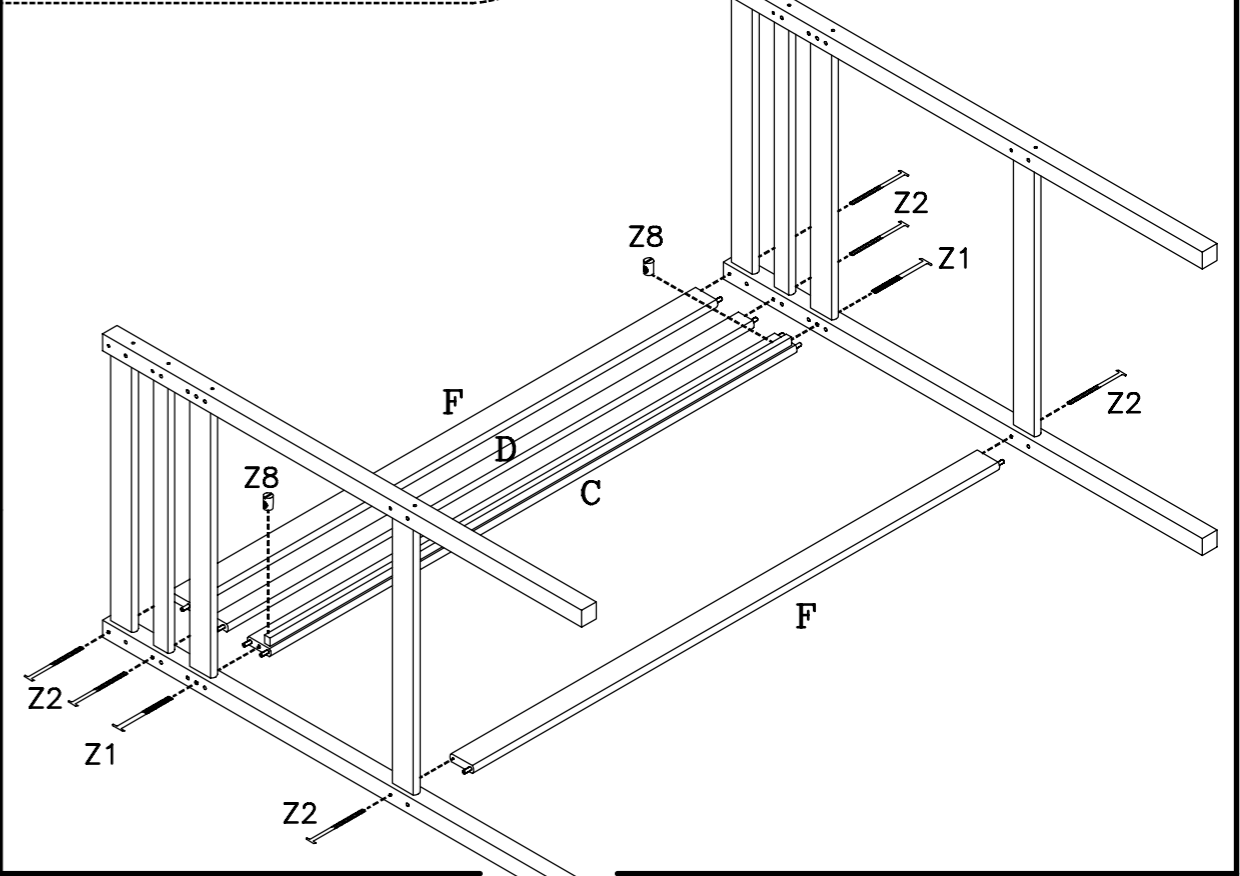
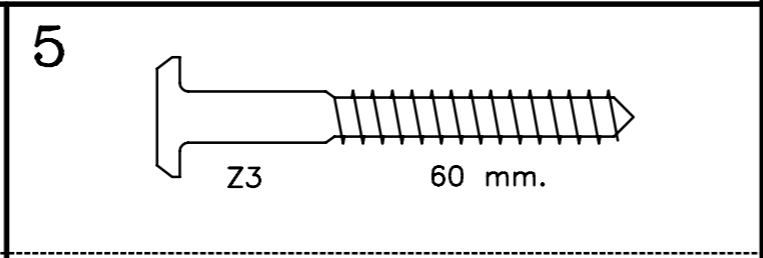
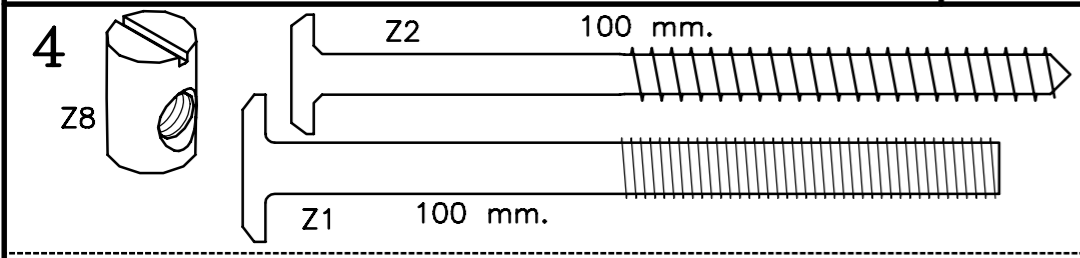
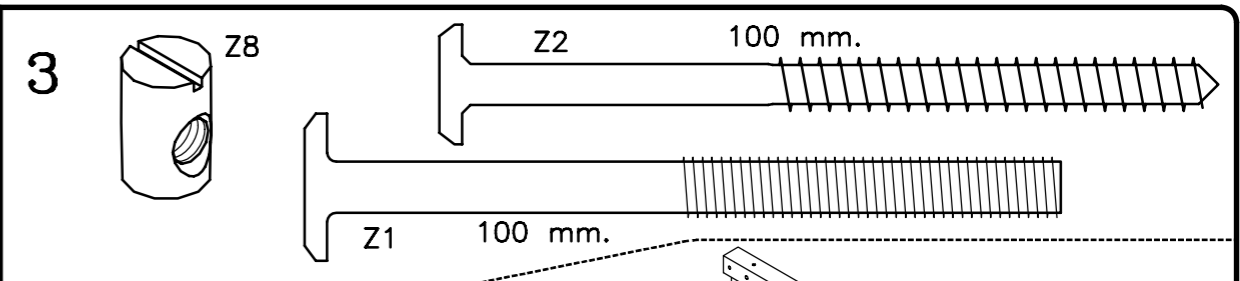
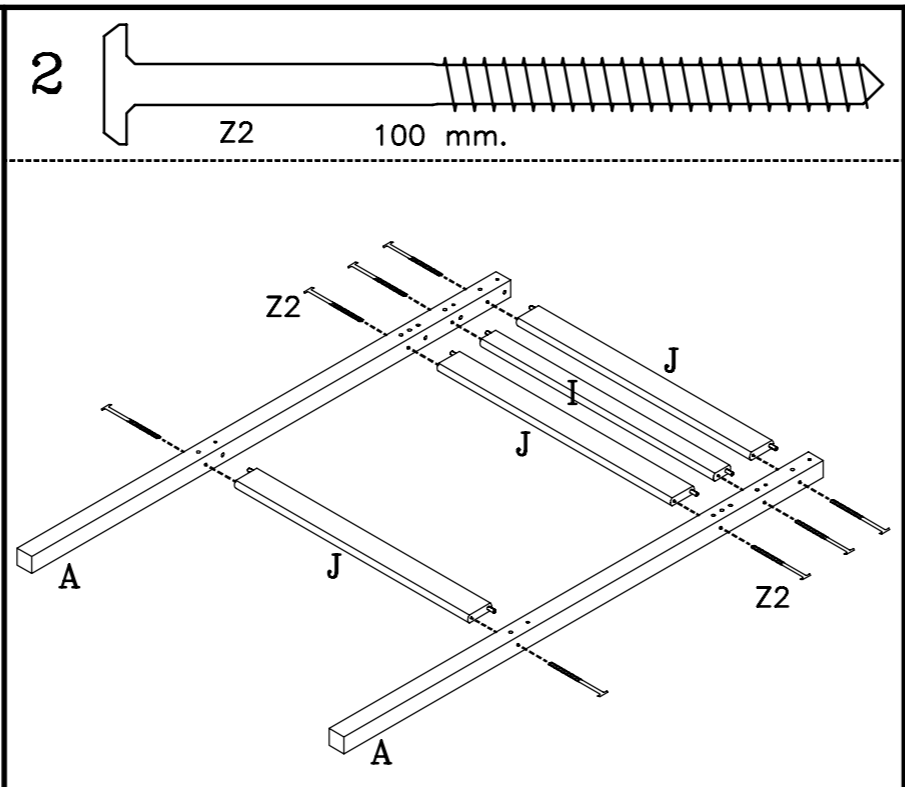
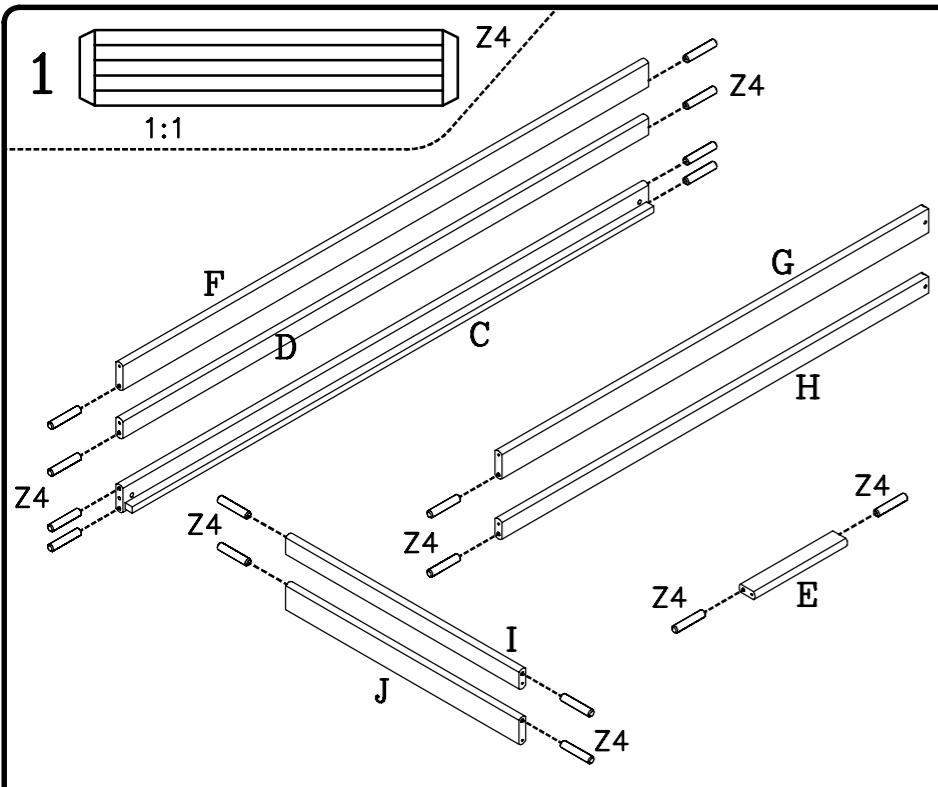

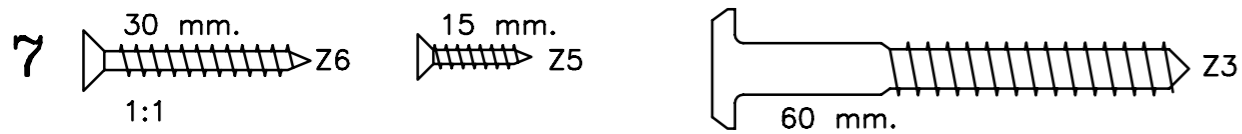

DK: Max. madrashøjde  
 D: Max. Höhe der Matratze  
 GB: Max. height of mattress  
 F: Hauteur max. du matelas  
 I: Altezza max. materasso  
 E: Altura del colchon máximo  
 NL: Maximale matrashoogte  
 CN: 床垫床褥之最高高度

**Sicherheitsanforderung:** Die Betten sind nach EN-Normen zertifiziert. Achten Sie bei der Benutzung des oberen Bettes durch Kleinkinder (unter 6 Jahren) auf Gefahr des Herunterfallens!  
**Safety requirements:** The beds are certified in accordance with EN-Norms. Be aware of the danger of young children (under 6 years) falling from the upper bunk!  
**Conforme aux exigences de sécurité:** Les normes en vigueur. Le couchage en hauteur ne convient pas à des enfants de moins de six ans.

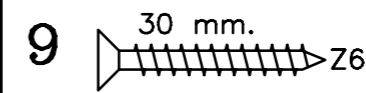
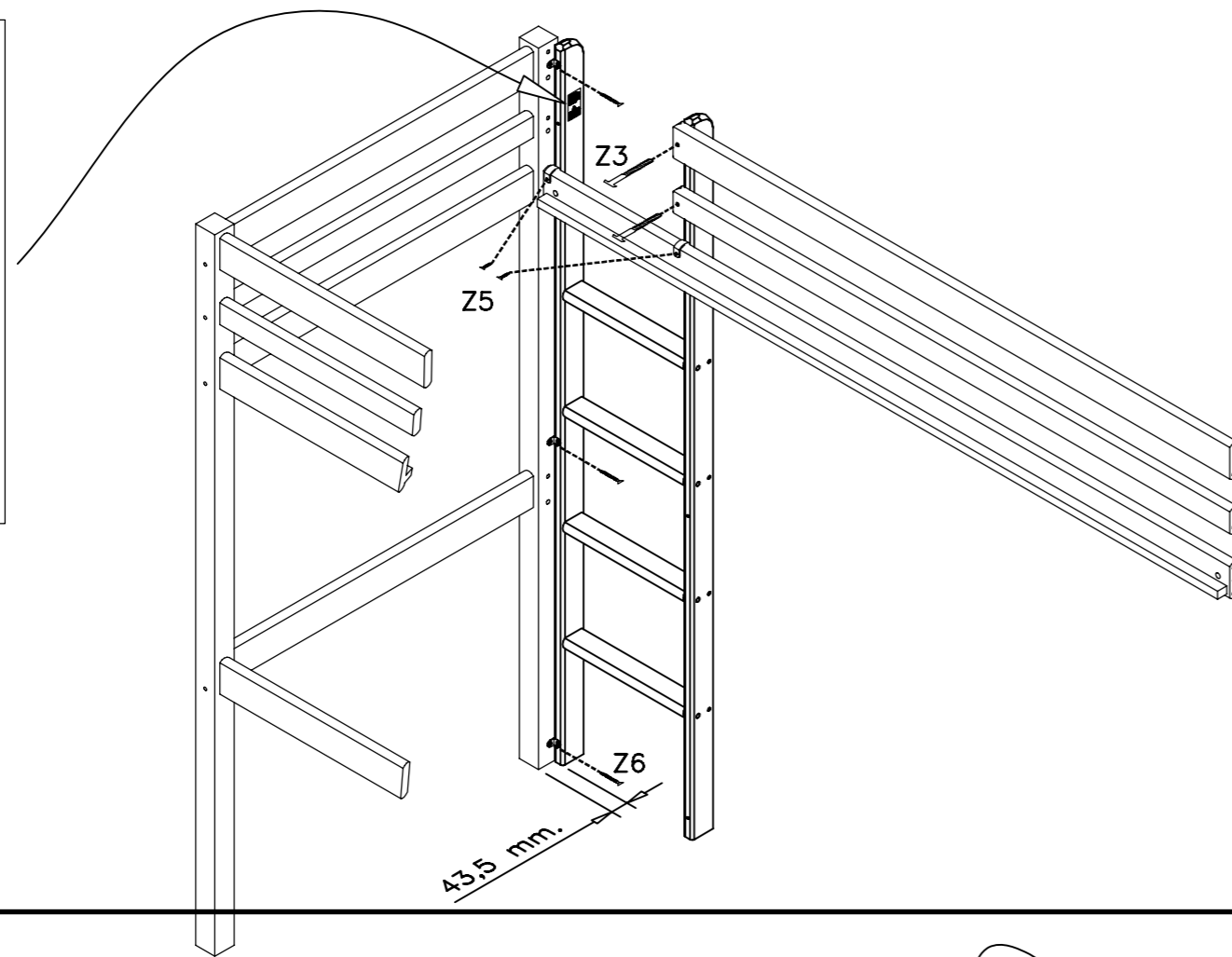

Push  
Drücken  
Appuyer

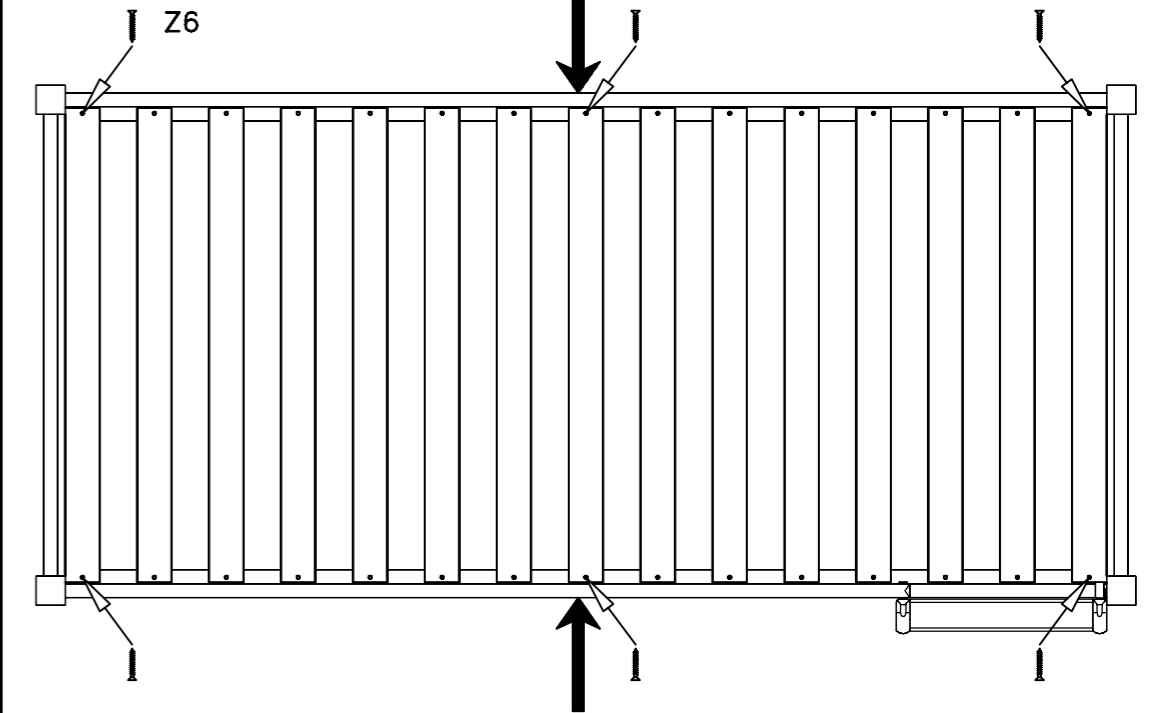

Push  
Drücken  
Appuyer

8

Important:

- Il est indispensable de fixer le lit mezzanine au mur avec les 2 équerres Z13
- Utiliser des vis et des chevilles adaptés votre mur.

Important!!

To secure the bed it is necessary to fix the bed to the wall by mounting the 2 brackets as shown on the illustration.

Wichtig!

Es ist notwendig das Bett an der Wand mit zu befestigen – siehe Zeichnung.

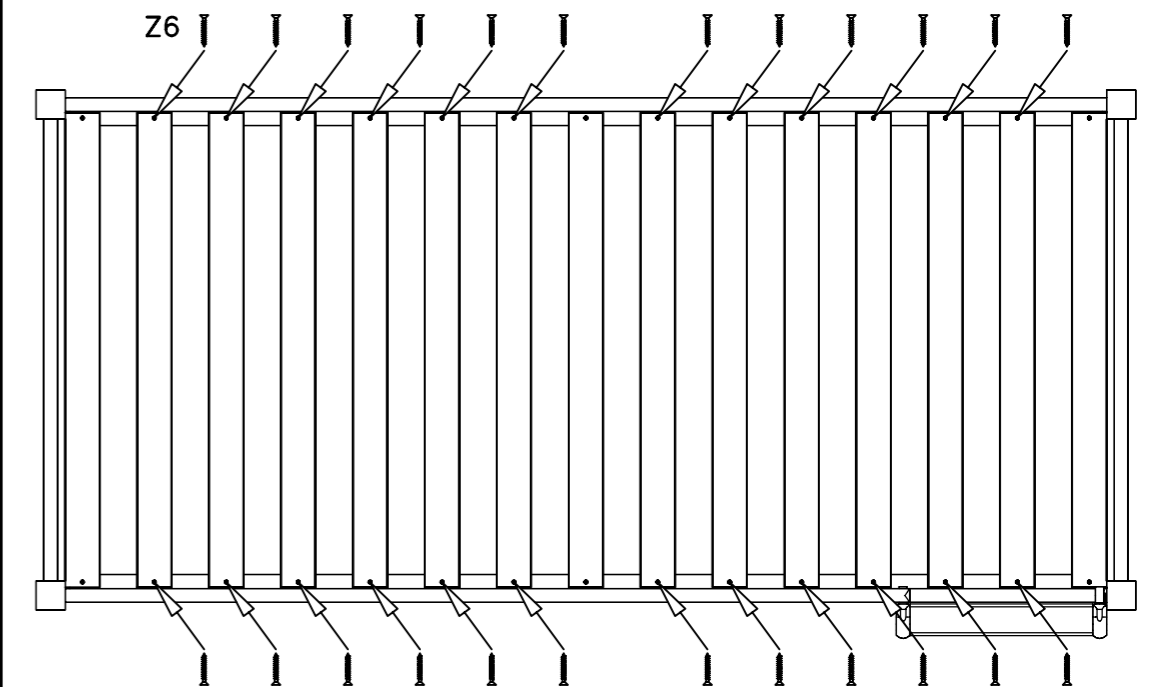
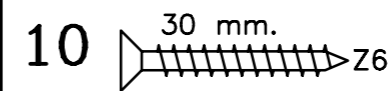
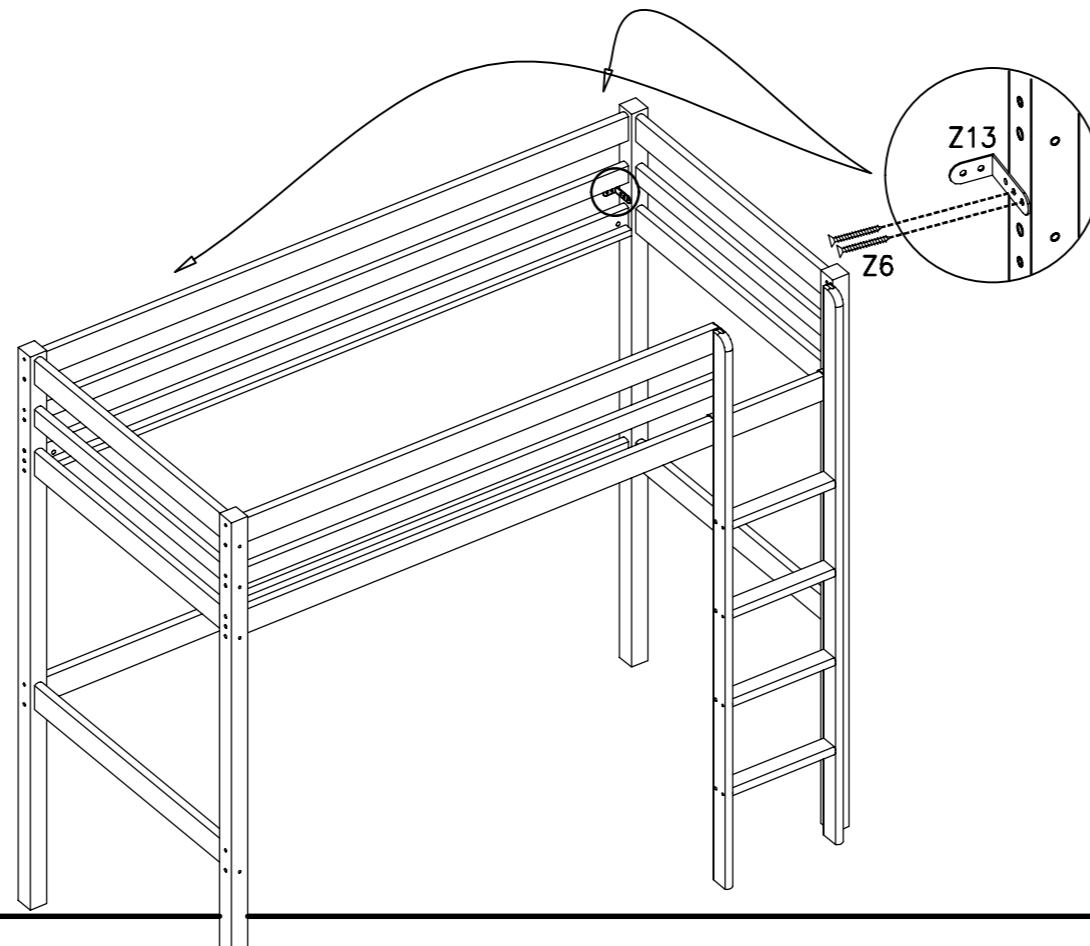

Please dispose of all packaging safely.

## General Care & Maintenance

Wipe clean with a slightly damp cloth.  
Avoid the use of all household cleaners and abrasives.

Periodically check all screw & fixings to ensure they are secure.

When moving your product, carefully lift into place. Never drag or push the product across the floor as this will cause damage to the joints. If the product is used on hard flooring, such as wood or laminated floor, you must place some protection under the legs to stop the product from moving. If this is not adhered to, it could result in failure to the product that will invalidate the warranty.

For more information on cleaning and product care visit:  
<https://www.happybeds.co.uk/help-and-advice>

## Notes

In the unlikely event that you have problems putting this product together or have damaged or missing parts, please contact us by visiting:  
<https://www.happybeds.co.uk/customer-service>