

Assembly Instructions

Important before assembly:

Read these instructions carefully before assembling or using the product.

Please check the contents of the boxes before attempting to assemble this product. The instructions will have a checklist of parts and fittings.

Assemble the product as close to its intended final location/room as possible.

Health & Safety:

This product or some parts of this product will be heavy. Please use an assistant when lifting.

Please keep small parts out of reach of children.

Always use on a level, even surface.

DO NOT jump on the product or any of its parts.

DO NOT use this product if any parts are missing, damaged or worn.

DO NOT use this product unless all fixings are secured.

Further instructions are on the following pages.

Please keep these instructions for future reference.

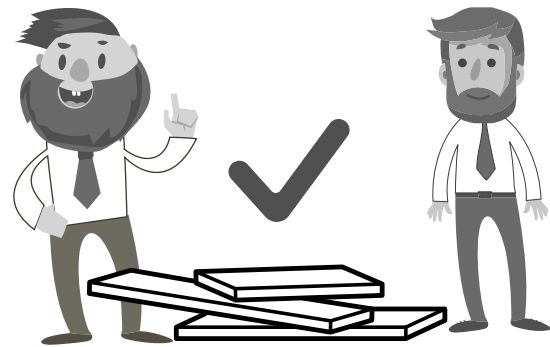
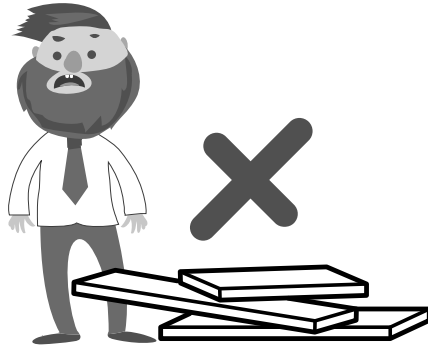
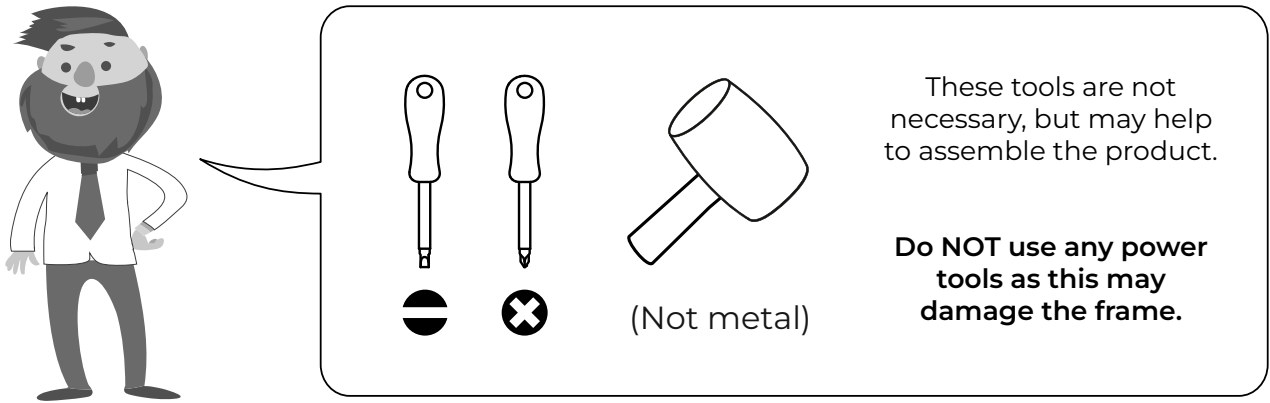

This product or some parts of this product will be heavy. Please use an assistant when lifting.

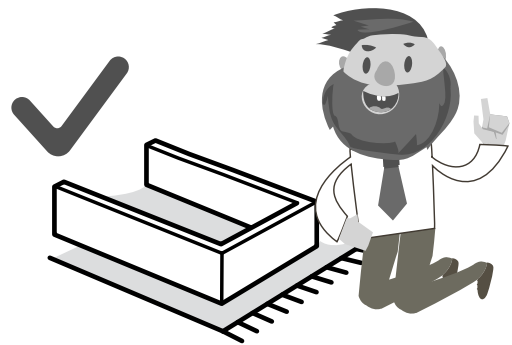
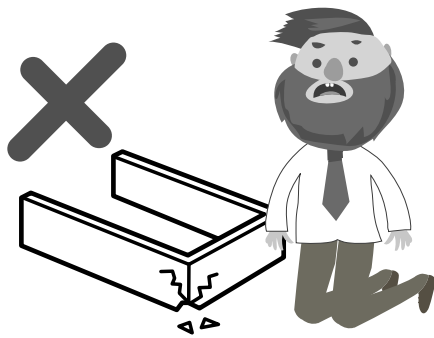

Never drag or push the pieces across a hard or stone floor as this will cause damage to the joints. Use a carpet or a rug for extra care.

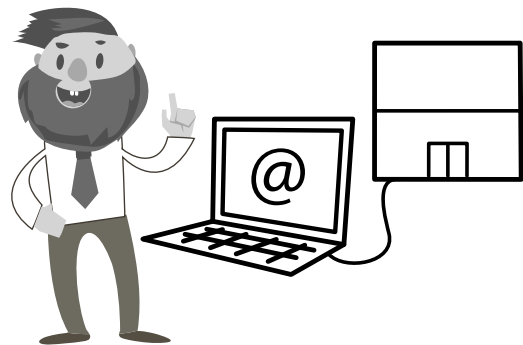
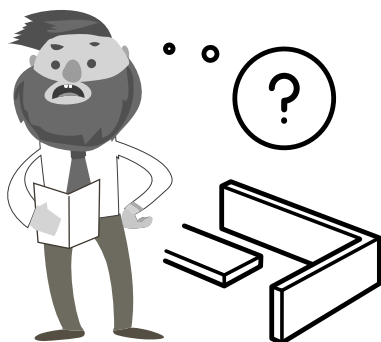

If you have problems assembling or have damaged or missing pieces, please contact our customer services (details at the back of these instructions)



Important for Ottoman and other gas lift beds

Note:

The bed base is in the upright position when first assembled as the gas lifts are fully extended during shipment for safety. After assembly a firm downward push will be required to overcome any resistance in the gas lifts as these may initially stick. We suggest placing a mattress on top of the bed base to aide this and also test the operation of your new lift up bed by lifting and pushing down the bed base a few times to allow the lifting mechanism to bed in.

The lift mechanism provides assistance with the lift of the mattress fitted to the base. It does not lift the mattress for you. The system has been designed to effectively lift the base system fitted with a variety of mattress weights and combinations of depths. Depending on the combination of the mattress weight and depth determines the degree of assistance provided by the mechanism.











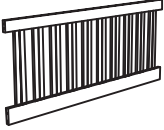

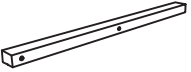
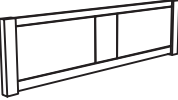
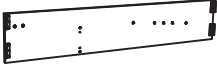

Following the installation of the mechanism lift, pull the base up and down a few times to free off the system. The gas cylinders fitted to the system may be stiff when first used or if the system has not been operated for a period of time.

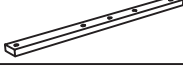





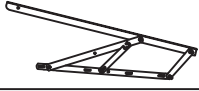
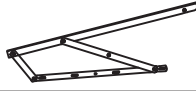



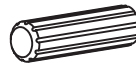



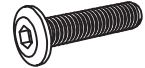







Use the strap handles to lift up the mattress base using two hands. Pull the mattress base down using two hands equally spaced from the centre of the mattress base. DO NOT pull down on one side of the base only as this is likely to damage the base system with potential failure of the mattress base system and lift mechanism.

Do NOT operate the lift up mechanism without the mattress placed on the base.

Caution:

Do NOT allow children to operate the lift mechanism.
Do NOT allow children near the lift base when operating the mechanism.
Do NOT allow children in the area of the internal storage base.
Keep hands clear of the mechanism when operating the base system.
Do NOT stand inside the bed or the internal storage base.
Do NOT overload the internal storage base.

Parts List				
Parts	Description		Qty	Box
1	Top Bar		2	3/3
2	Headboard Frame		1	1/3
3	Left Wooden Post		1	1/3
4	Right Wooden Post		1	
5	Footboard		1	1/3
6	Left Side Rail		1	3/3
7	Right Side Rail		1	
8	Centre Storage Panel		1	
9	Back Storage Panel		1	1/3
10	Hydraulic Arm Spacer		2	
11	Left Side Metal Bar		1	2/3
12	Right Side Metal Bar		1	
13	Headboard End Metal Bar		1	
14	Footboard End Metal Bar		1	
17	Slat		14	
18	Left Hydraulic Base Support c/w Pump Stopper		1	
19	Right Hydraulic Base Support		1	
20	Hydraulic Base Pump		2	

Hardware List(Found in box#)			
Parts	Description	QTY	Box
A	Mini Fix 	14	3/3
B	8 x 30 mm Wooden Dowel 	12	
C	Metal Corner Block 	2	
D	M6 x 90 mm Barrel Nut 	4	
E	M6 x 16 mm JCBC Bolt 	8	
F	M8 x 20 mm JCBC Bolt 	16	
G	M8 x 15 mm JCBC Bolt 	8	
H	M8 x 45 mm JCBC Bolt 	14	
I	Bracket 20 mm x 58 mm 	4	
J	Base Handle 	2	
K	M8 Nut 	4	
L	Plastic Washer 	8	
M	Slat Cap 	28	
O	Wooden Button 	4	3/3
P	Belt Handle 	1	
Q	Washer Bracket 	4	
R	Flat Washer 	22	
S	M8 x 40 mm JCBC Bolt 	8	
T	M6 Allen Key 	1	
U	M8 Allen Key 	1	
V	M12.8 Spanner 	1	
W	Washer Bracket 	6	
X	Spring Washer 	22	
Y	Sticker 	10	

Step 1: Attach the headboard frame (2) and back storage panel (9) to the left wooden post (3) and right wooden post (4). Secure the headboard frame using hardware parts B, D and O, then secure the back storage panel with hardware parts B,E and I.

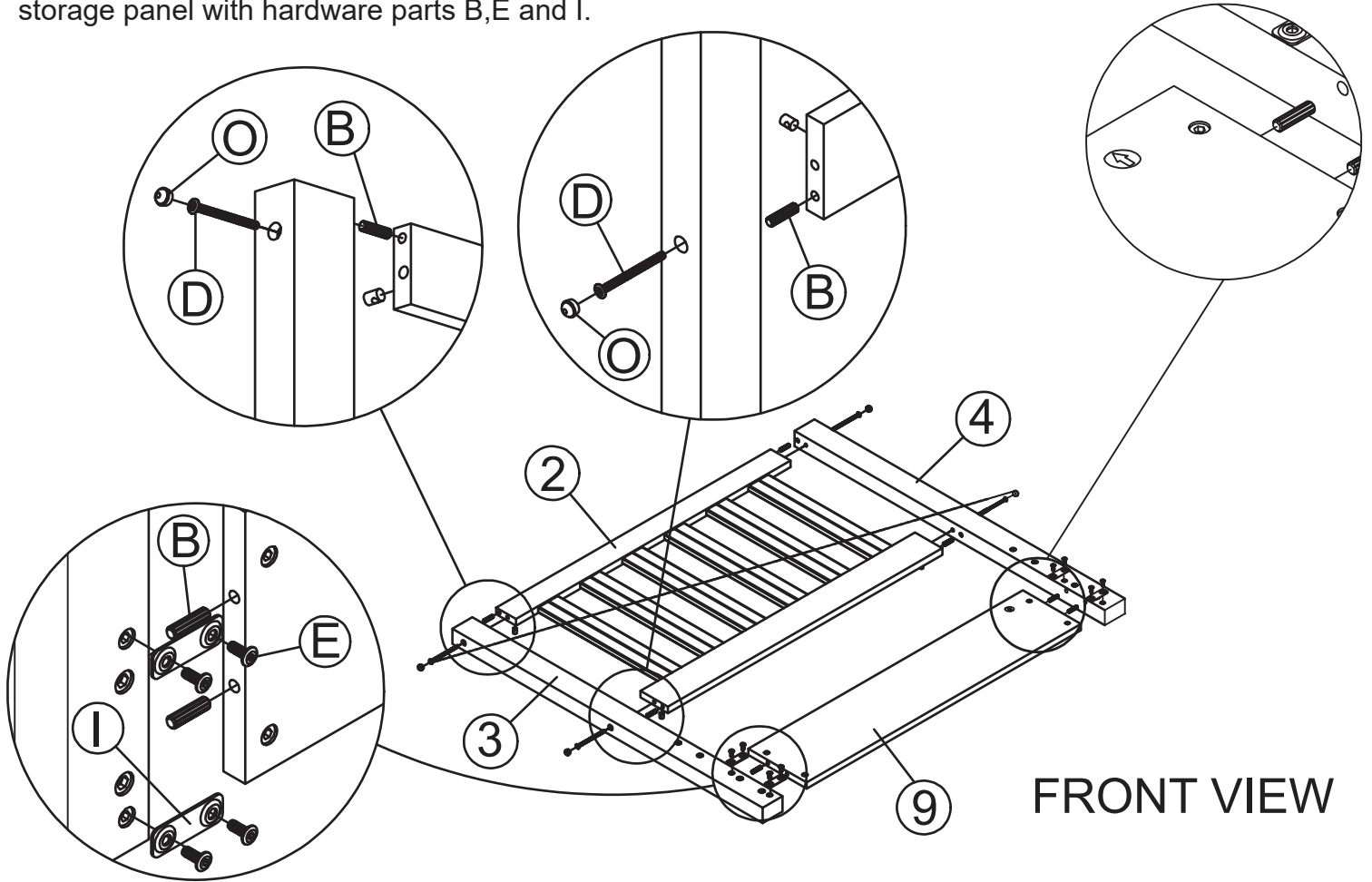

FRONT VIEW

Step 2: Firstly screw the minifit part A to the top bar (1) as shown and then fix the top bar (1) to the headboard frame (2) and L/R wooden post (3)(4) using hardware parts A; then paste the sticker Y.

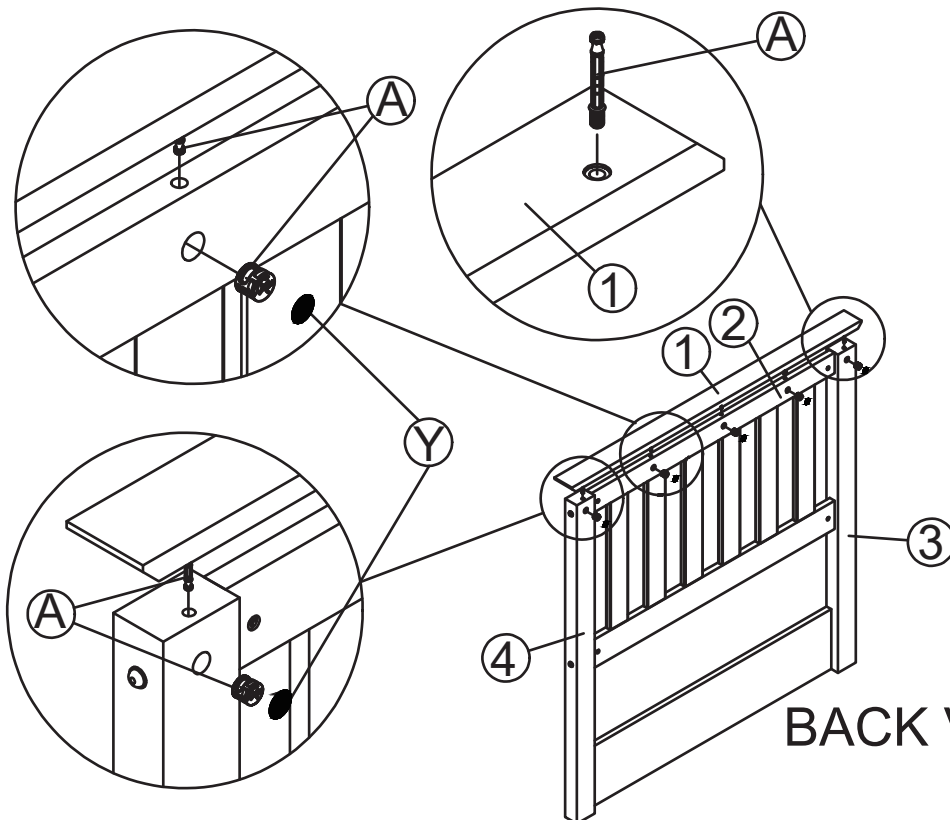

BACK VIEW

Step 3: Firstly screw the minifit part A to the top bar (1) as shown and then fix the top bar (1) to the footboard frame (5) using hardware parts A; then paste the sticker Y.

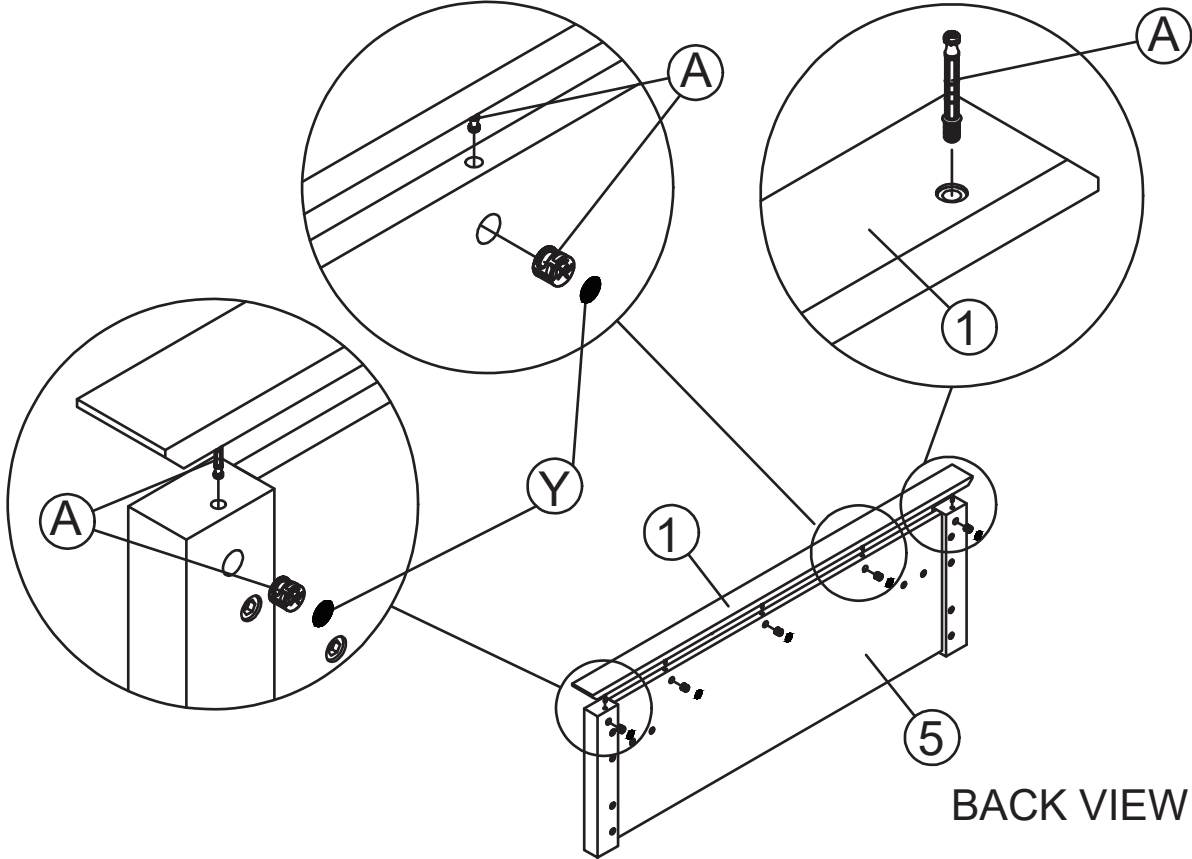

Step 4: Firstly, fix the hydraulic pump to each hydraulic base as shown in diagram 4.1. Next fix the left and right hydraulic spacer together with the hydraulic base supports on to both side rails using bolts H. **Ensure Plastic washers (part L) are used between the Hydraulic spacer (part 10) and the hydraulic base support (parts 18/19) as shown in the image.** Then screw the minifit part A to both side rails as shown in diagram 4.2.

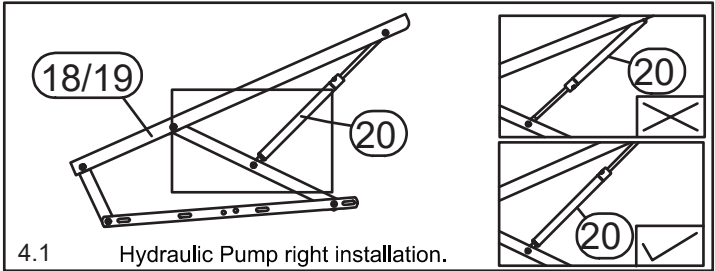

⚠ Attention: Please close to the headboard side when assemble the hydraulic base support !!!

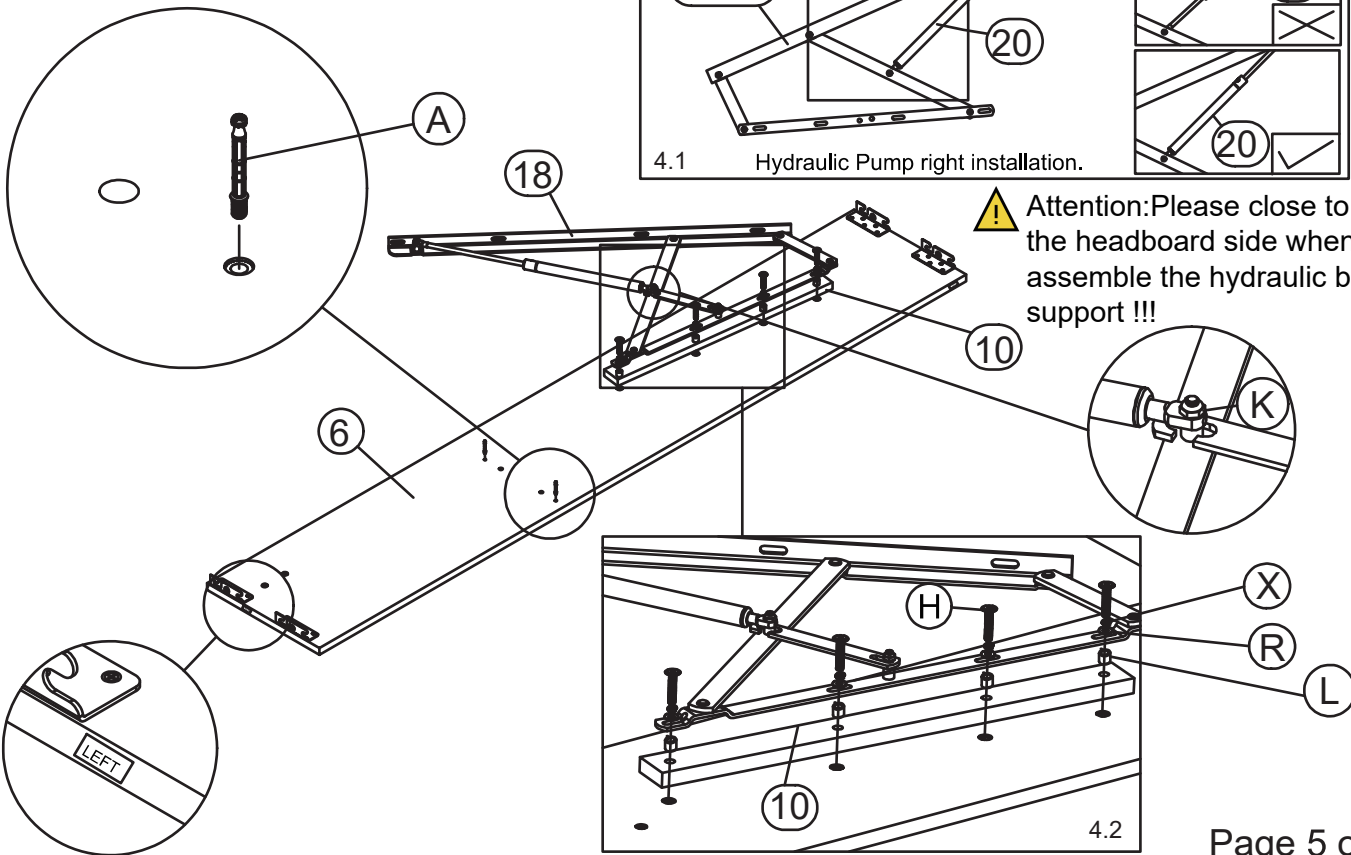

Step 5: Join together the left side rail (6) and right side rail (7) with the centre storage panels (8) using hardware parts A and B.

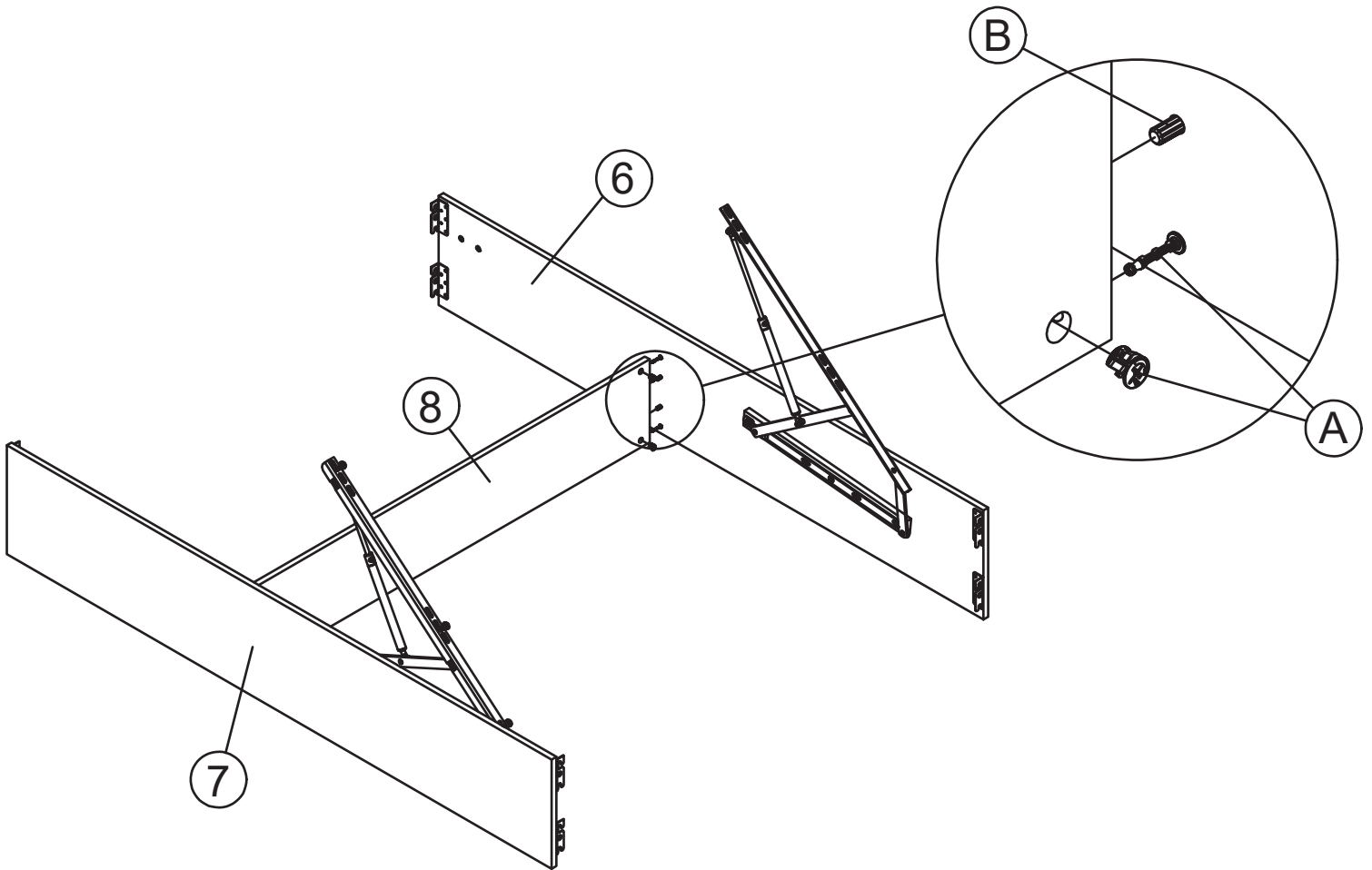

Step 6: Fix side rail to the headboard and footboard with hardware as shown.

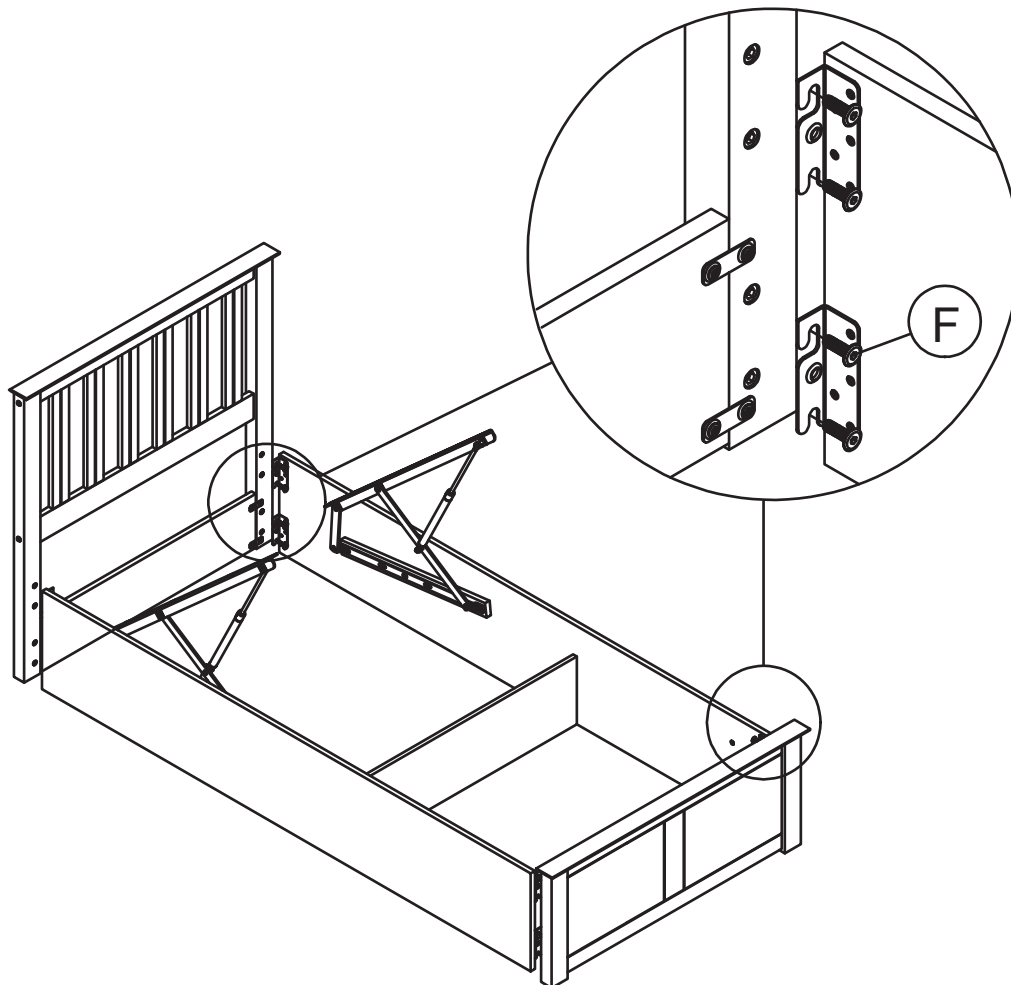

Step 7: Fix metal corner block C to the edge of footboard and side rails with bolt G as shown.

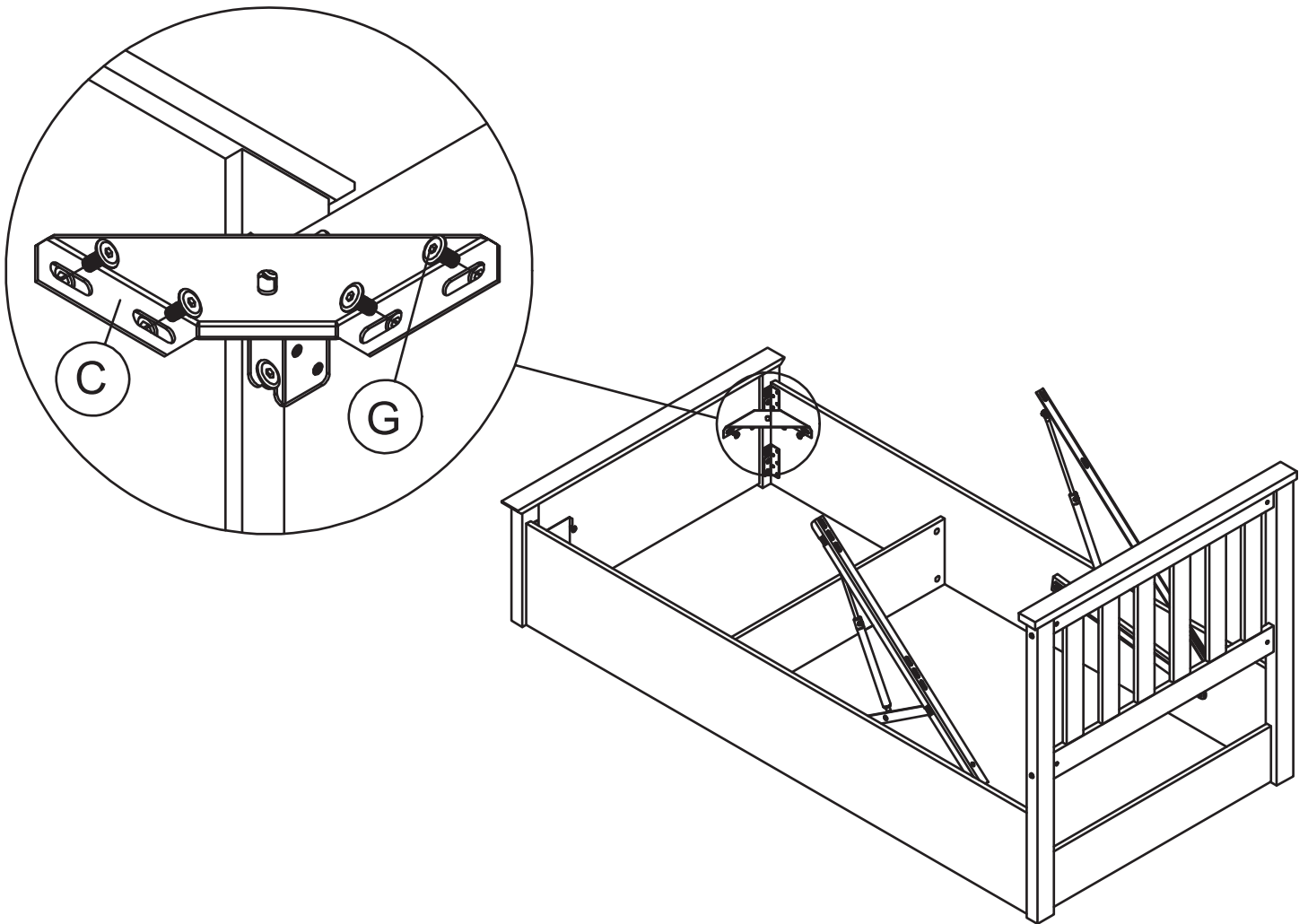

Step 8: Join together all the bed base parts (11),(12),(13) and (14) using hardware parts G,X & R and also slide part P onto Part 14 before bolting together. And then attach hardware parts J as shown. Important note: Please assemble follow arrow direction.

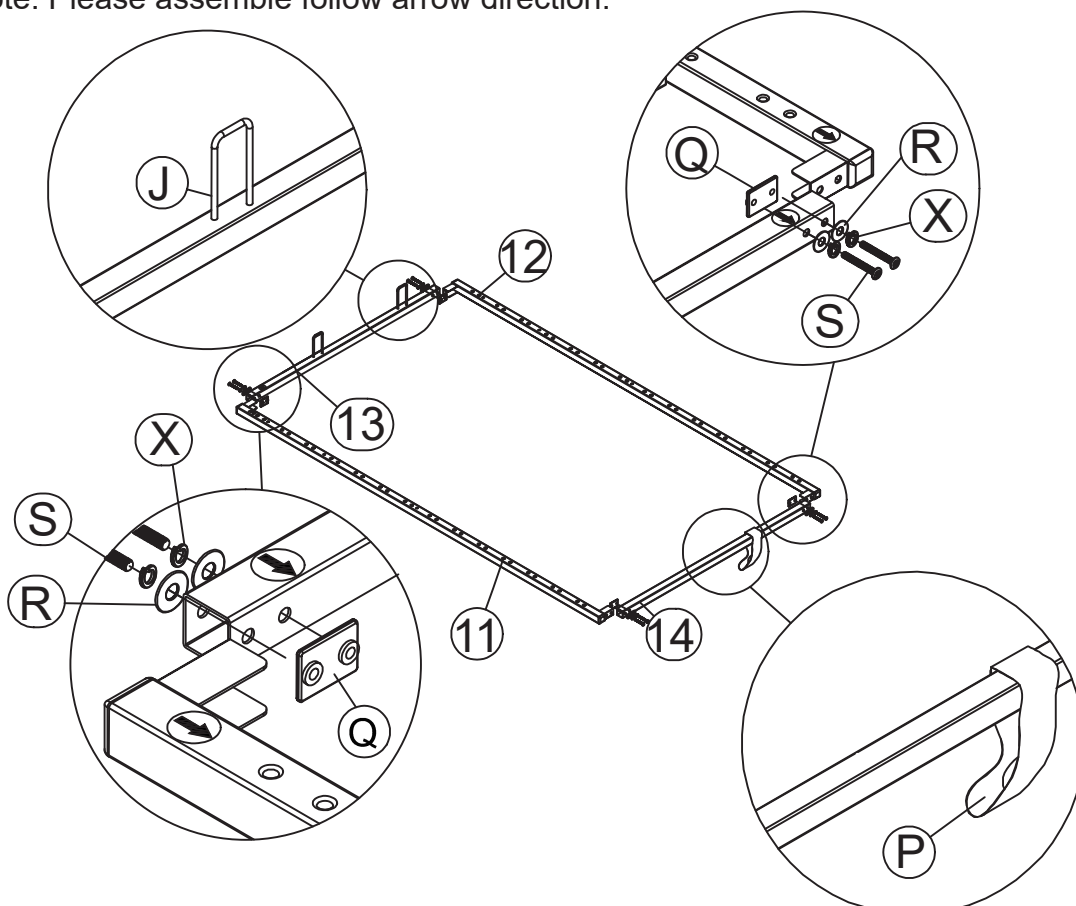

Step 9: Insert the slats (17) to hardware parts M then press into the base making sure they are secure.

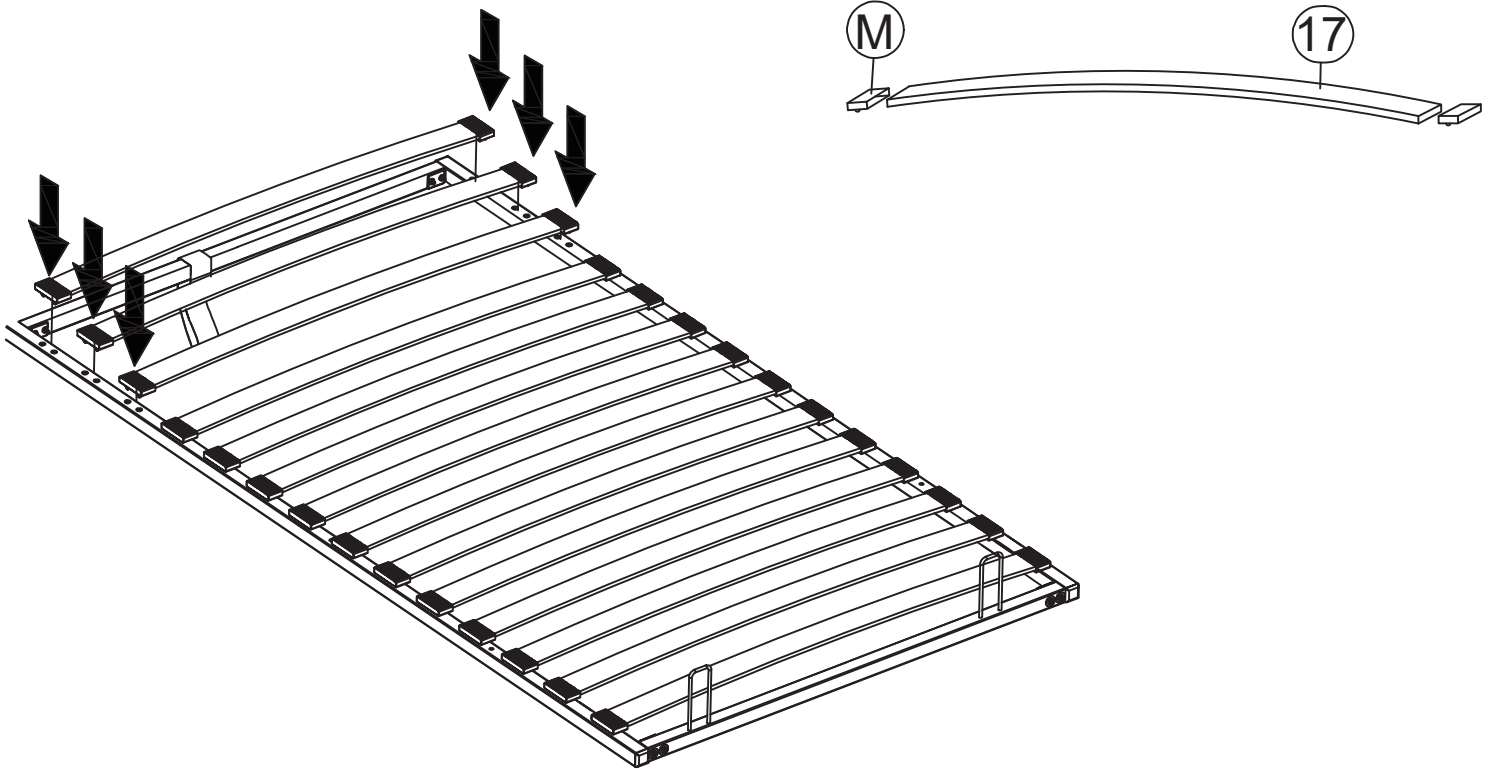

Step 10: Assemble the bed base on the right & left hydraulic frame and fix bolts starting from '1' to '3' as shown .

Important note: Do not tighten the bolts yet!, and this assemble must be done by two persons.

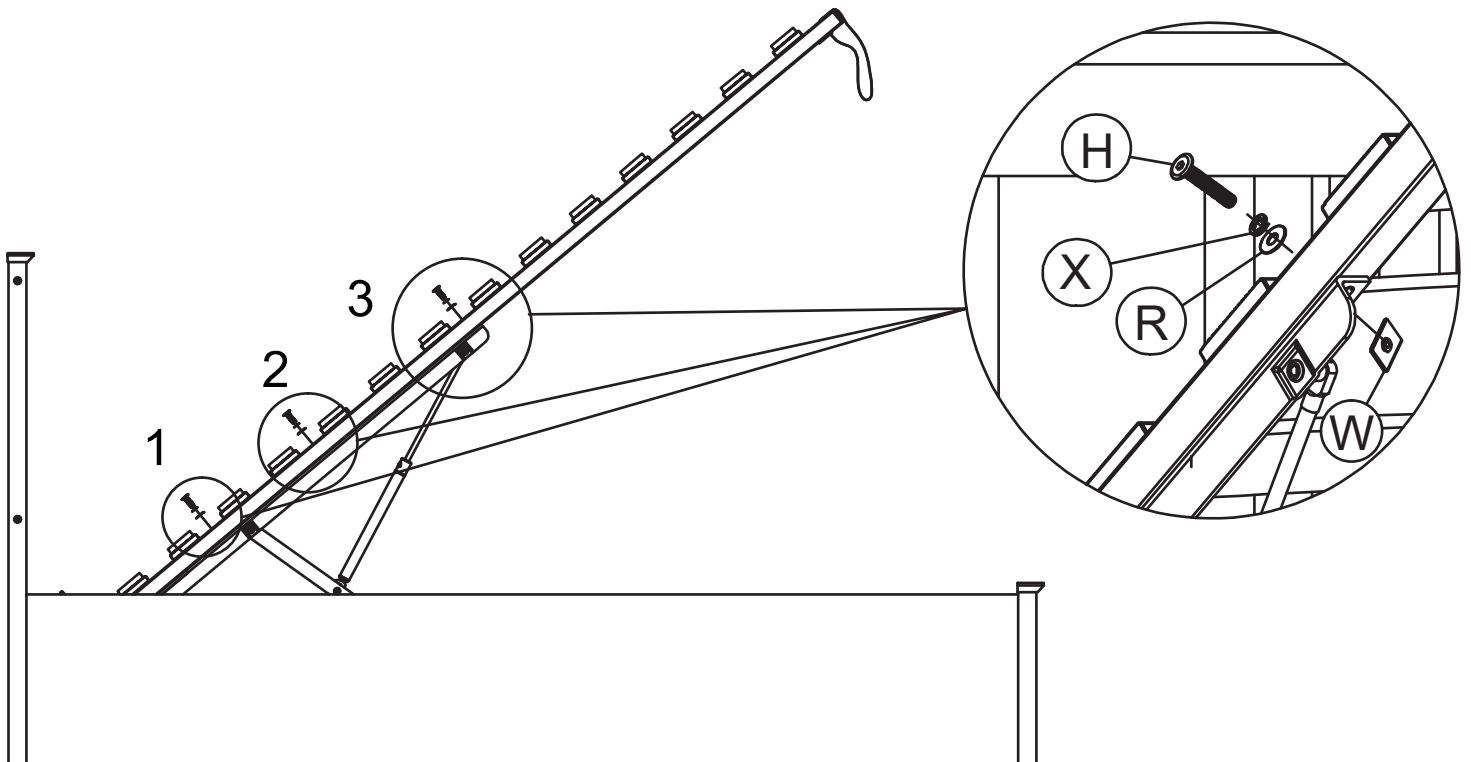

Step 11: Adjust the bed base making sure that the distance to the footboard is approximately

15 mm to above. Tighten all bolts and screws now.

HEADBOARD

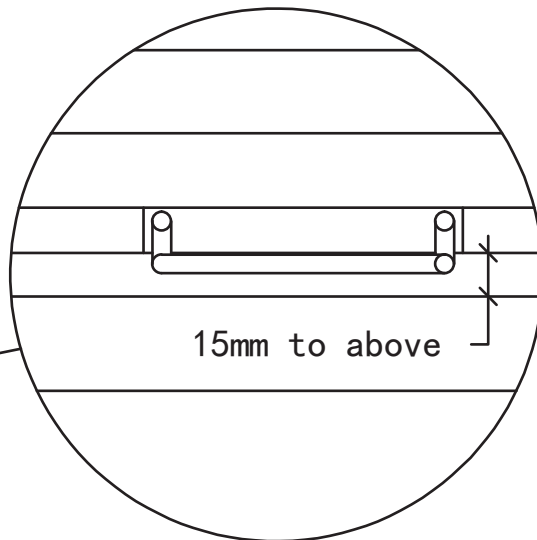
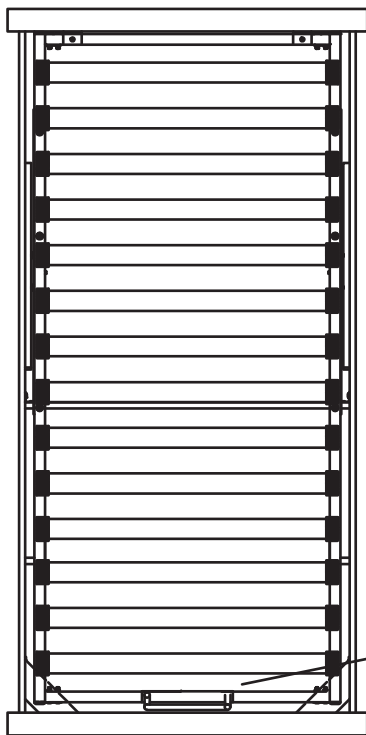

FOOTBOARD

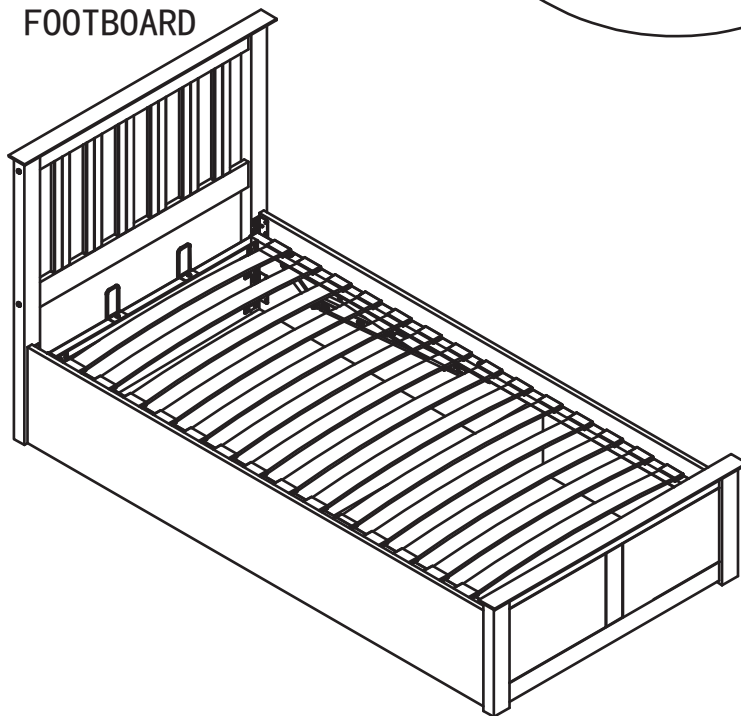



CAUTION :

PLEASE USE HYDRAULIC PUMP STOPPER FOR SAFETY PURPOSE.

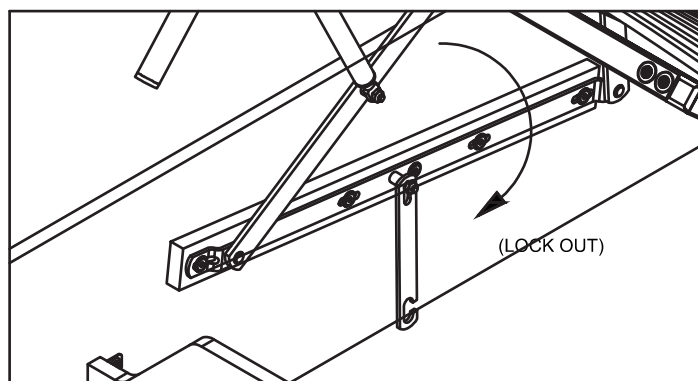
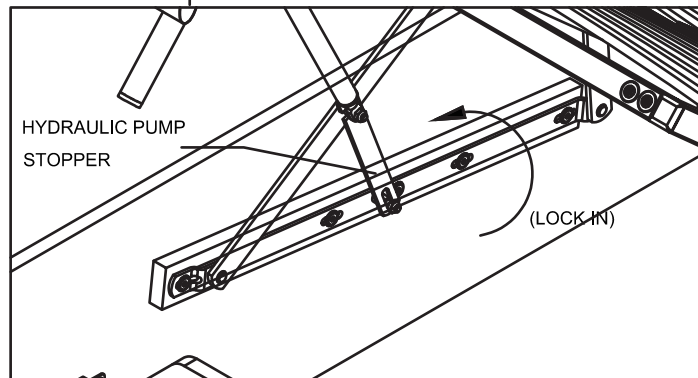
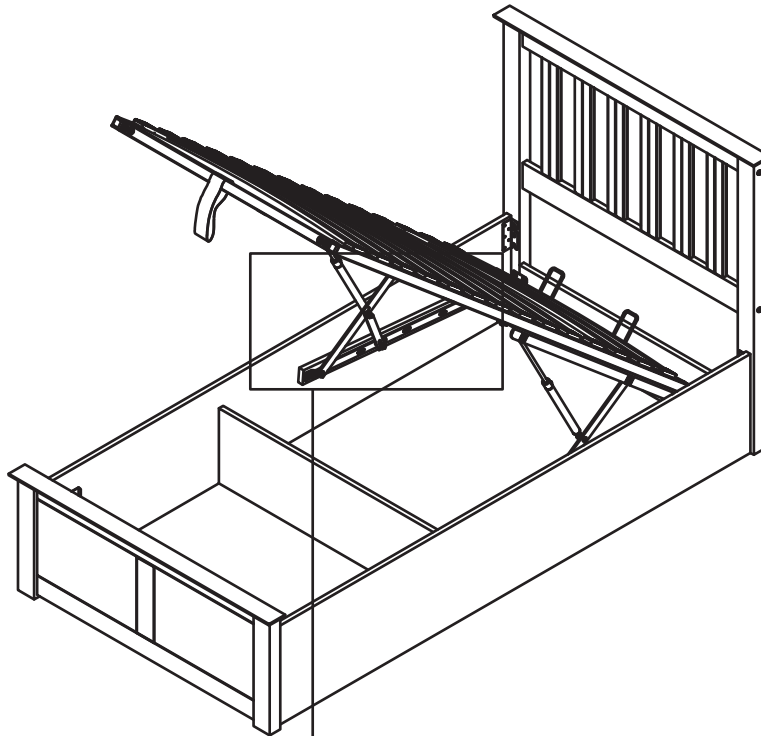

Important for Ottoman and other gas lift beds

Please follow these final steps to ensure the best experience with your new bed

- Please ensure the pistons are fitted to the bed frame.
- Please place the mattress on top of the bed frame.
- Standing at the foot of the frame (looking at the headboard) open the base and the press quite forcefully down on the mattress - please do not attempt to do this without the mattress being in place.
- Please do not pull on the strap handles.
- Please note as the pistons are full of gas - you will need to press heavily to release the compressed gas.
- Once done the pistons should start operating as normal.



Please dispose of all packaging safely.

General Care & Maintenance

Wipe clean with a slightly damp cloth.
Avoid the use of all household cleaners and abrasives.

Periodically check all screw & fixings to ensure they are secure.

When moving your product, carefully lift into place. Never drag or push the product across the floor as this will cause damage to the joints. If the product is used on hard flooring, such as wood or laminated floor, you must place some protection under the legs to stop the product from moving. If this is not adhered to, it could result in failure to the product that will invalidate the warranty.

For more information on cleaning and product care visit:
<https://www.happybeds.co.uk/help-and-advice>

Notes

In the unlikely event that you have problems putting this product together or have damaged or missing parts, please contact us by visiting:
<https://www.happybeds.co.uk/customer-service>