



## Assembly Instructions

# Thornberry 4FT6 TV Bed



### Important before assembly:

Read these instructions carefully before assembling or using the product.

Please check the contents of the boxes before attempting to assemble this product. The instructions will have a checklist of parts and fittings.

It would be sensible to lay a rug or a carpet on the floor where you intend to assemble the product, to avoid scratches and damaging the product or the floor.

Assemble the product as close to its intended final location/room as possible.

Do NOT use any power tools as this may damage the frame.

### Health & Safety:

This product or some parts of this product will be heavy. Please use an assistant when lifting.

Please keep small parts out of reach of children.

Always use on a level, even surface.

DO NOT jump on the product or any of its parts.

DO NOT use this product if any parts are missing, damaged or worn.

DO NOT use this product unless all fixings are secured.

Please keep these instructions for future reference.

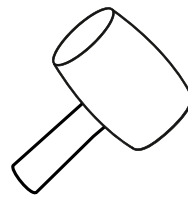
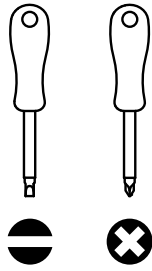
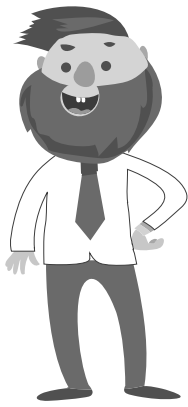

(Not metal)

These tools are not necessary, but may help to assemble certain parts of the product.

Do NOT use any power tools as this may damage the frame.

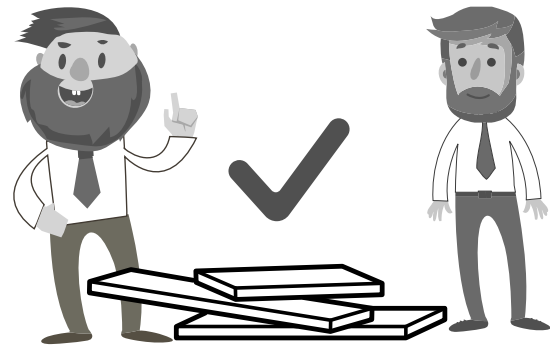
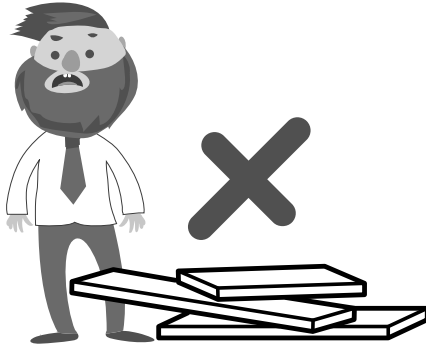

This product or some parts of this product will be heavy. Please use an assistant when lifting.

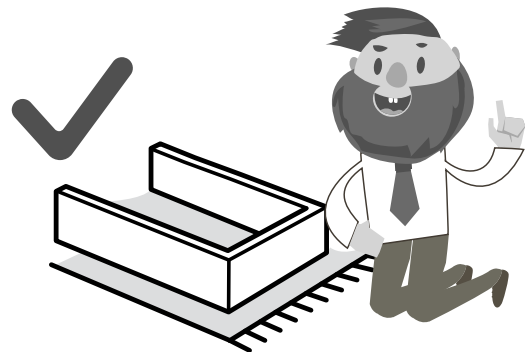
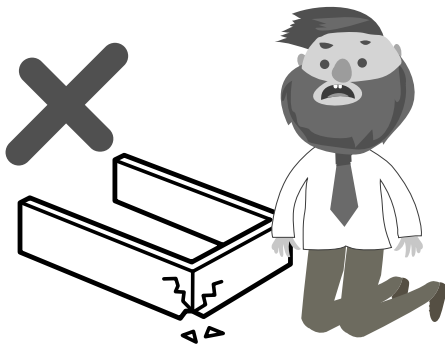

Never drag or push the pieces across a hard or stone floor as this will cause damage to the joints. Use a carpet or a rug for extra care.

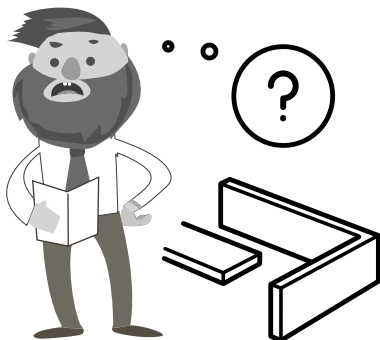

If you have problems assembling or have damaged or missing pieces, please contact us by visiting:

<https://www.happybeds.co.uk/customer-service>

# PARTS LIST

NO.	PART LISTS	QTY
1	HEADBOARD	1
2	FOOTBOARD	1
3	SIDE RAIL	2
4	CENTRE RAIL	1
5	TOP TIE RAIL	1
6	SLATS	30

CARTON 1 CONSISTS OF PART : 1, LEGS  
CARTON 2 CONSISTS OF PART : 2, LEGS  
CARTON 3 CONSISTS OF PART : 3, 4, 5, HARDWARE  
CARTON 4 CONSISTS OF PART : 6, SLATS CAPS

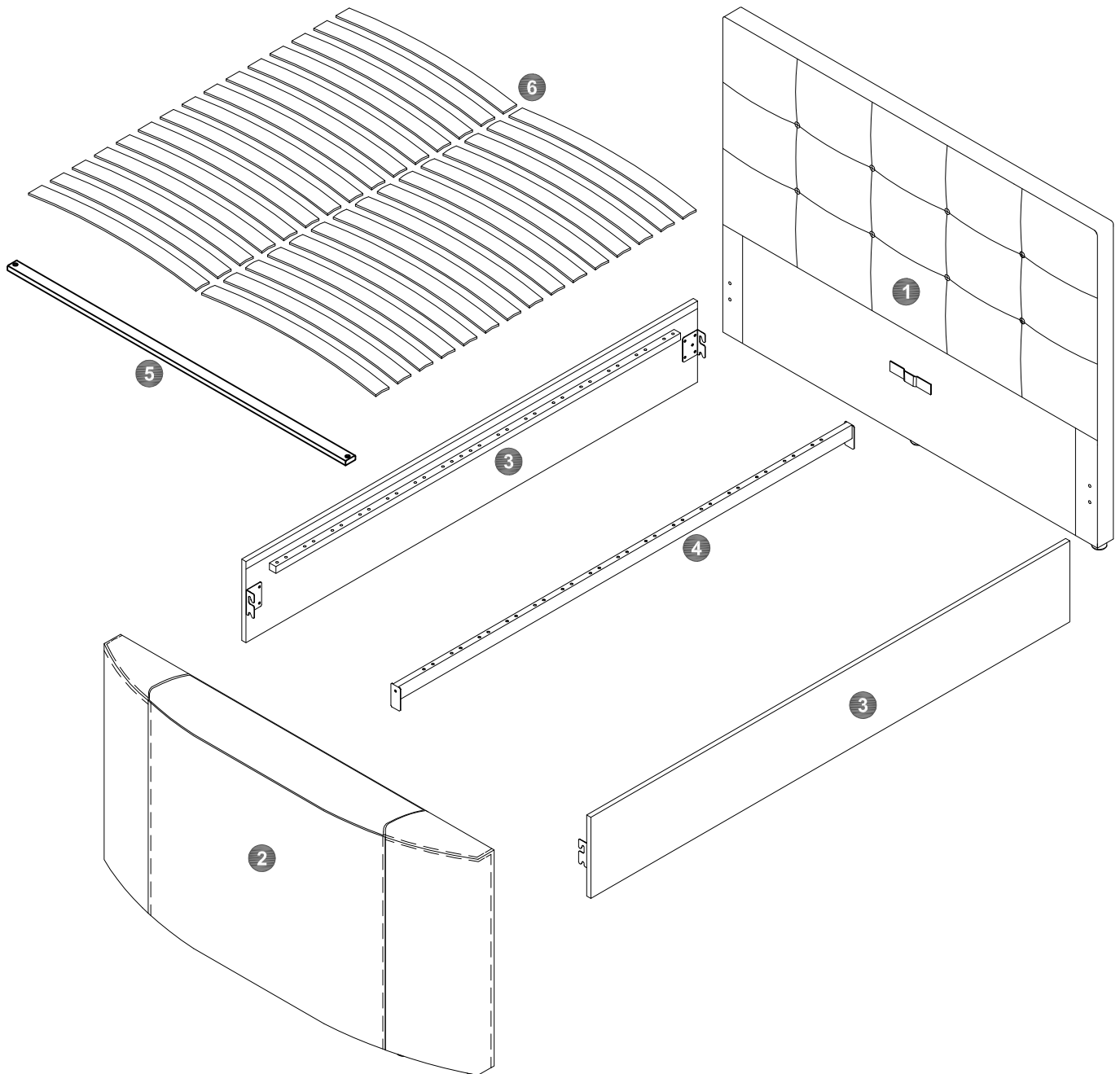

# HARDWARE LIST

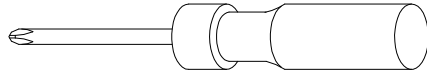

**1x**

**A**

SCREW DRIVER  
(4" x 5mm)

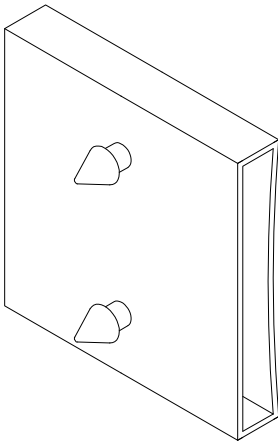

**15x**

**B**

CENTRE CAP

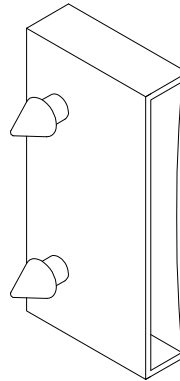

**30x**

**C**

END CAP

## **Top Tips before you start!**

1. Please check that all parts are present before you start the assembly of your furniture, as once assembled, the furniture is exempt from our home approval policy.
2. For ease and speed of assembly, we recommend that before you commence each step of the assembly, that you identify all the parts required for that step.
3. For larger items, please ensure that you have sufficient space and people (as indicated on page 1) to assemble your product safely.
4. We recommend that, where possible, all items are assembled near to the area in which they will be placed in use, to avoid moving the product unnecessarily once assembled.
5. For the protection of your furniture, particularly items of high gloss finish, we recommend that the product is placed on a protected surface during assembly to prevent any damage.
6. During assembly please take care not to over-tighten any fittings, as this may damage the product.

**DO NOT USE ANY POWER TOOLS AS THIS MAY DAMAGE THE FRAME AND WILL  
INVALIDATE ANY CLAIM**

# STEP 1

- Loosen the bolts located in the head end. (Note: only loosen the bolts Do NOT remove them.)
- Hook the side rail over the bolts as shown.
- Repeat the action on the opposite side.

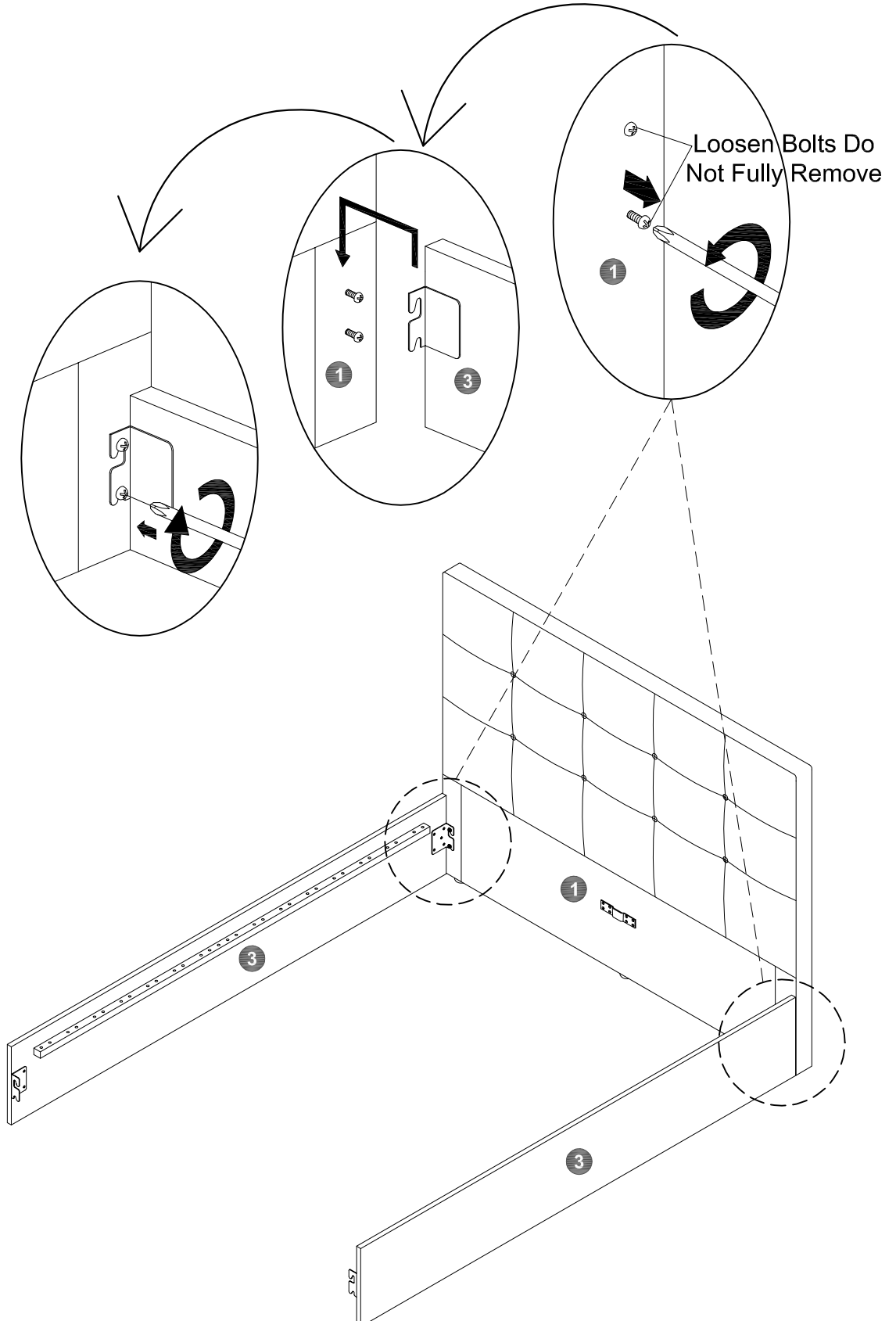

## STEP 2

- Carefully remove the footboard from carton 2, remove the Hardware Box and all extra transportation packaging from inside.
- To do this you will need to gently lay the foot end on it's back. Before doing so please ensure the area is completely free of anything that may cause damage or press into the fabric. Place a protective cover on the floor to avoid possible damage.
- The controls and hardware are held in place by string please carefully cut these and remove.

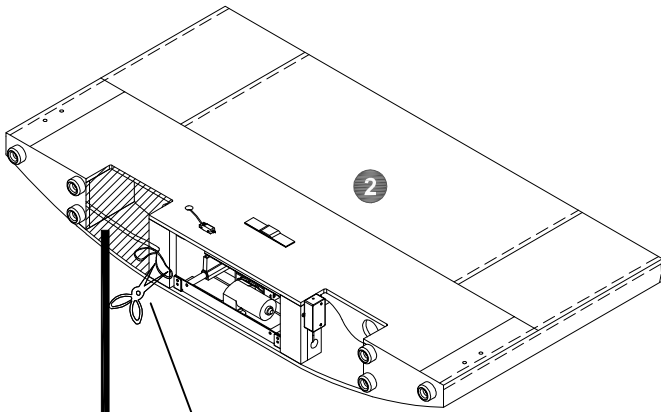

**CAUTION:**  
PLEASE USE SCISSORS TO CUT THE STRING.  
TAKE CARE WHEN REMOVING THE ACCESSORY BOXES NOT TO CATCH YOUR HANDS ON THE SIDES.

Hardware Box

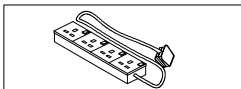
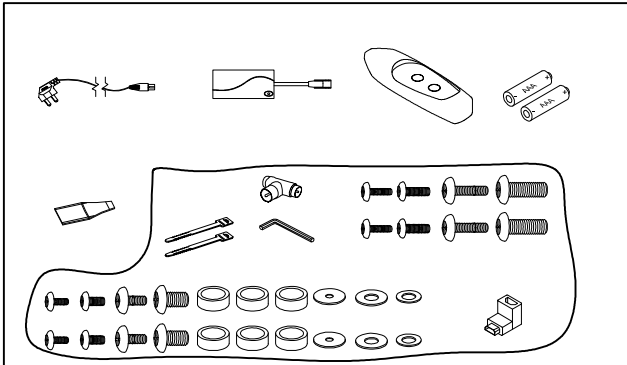

YOUR TELEVISION REAR VIEW  
HDMI CABLE PLUG POSITION POSSIBLE SCENARIO'S

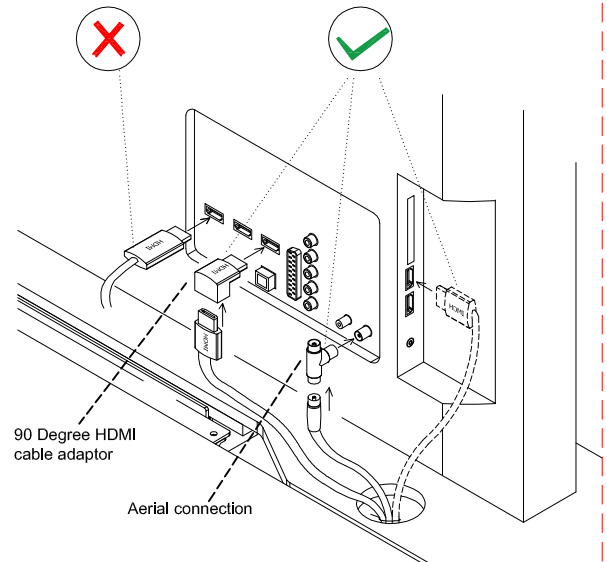

**Attention Please Note : Connecting Your HDMI or Aerial Cable as shown in diagram (X) can seriously Damage Your TV sockets.**

To reduce this possibility we have supplied 90 degree adaptors for both HDMI and Aerial connections.

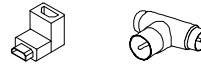

This will reduce the cable protrusion and lessen the possibility of the cable colliding with the bed frame.

**These can be found in the bed frame hardware pack located in Box B (foot end).** Please refer to the diagram above for the correct fitting of cables. More detailed information can also be found on step 15 of your assembly instructions.

**The manufacturer or retailer will not accept responsibility for any damages arising from incorrect installation.**

## ATTENTION! PLEASE NOTE:

In the event you are experiencing any technical difficulties and you require additional assistance/ support with your product 'Mechanical/ Electrical' function - Please contact:

SUPPORT EMAIL : [support@bssbfurnitureinnovation.com](mailto:support@bssbfurnitureinnovation.com)

UK PRODUCT SUPPORT HOTLINE : 01462600064

Contact your retailer for all other issues such as damage, missing or faulty components ( non electrical ) or anything else of a non technical/electrical nature.

## STEP 3

- Carefully lift the foot end back to it's upright position.
- Loosen the bolts located in the foot end.
- Please note these should only be loosened and **NOT** removed.
- Hook the side rail brackets over the bolts on both sides.

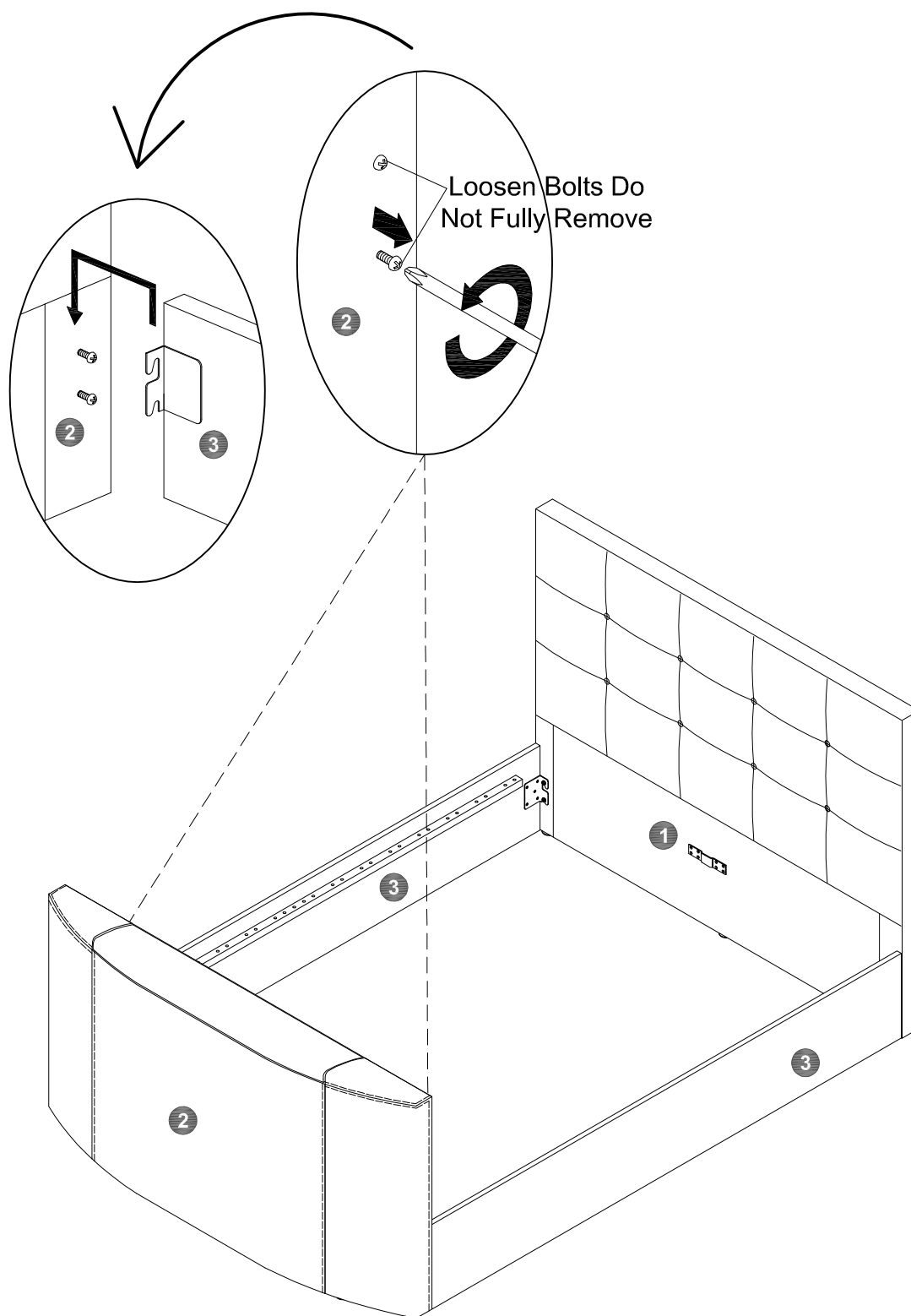

## STEP 4

- (A) Carefully slot the centre rail into the brackets on the head and foot end. Be very careful not to catch the head and foot ends with the centre rail tongue.
- (B) Fully tighten all screws on the head and foot ends.
- (C) Remove the screw pre-installed at the side rail. Attach the top tie rail & fully tighten with the screws provided.

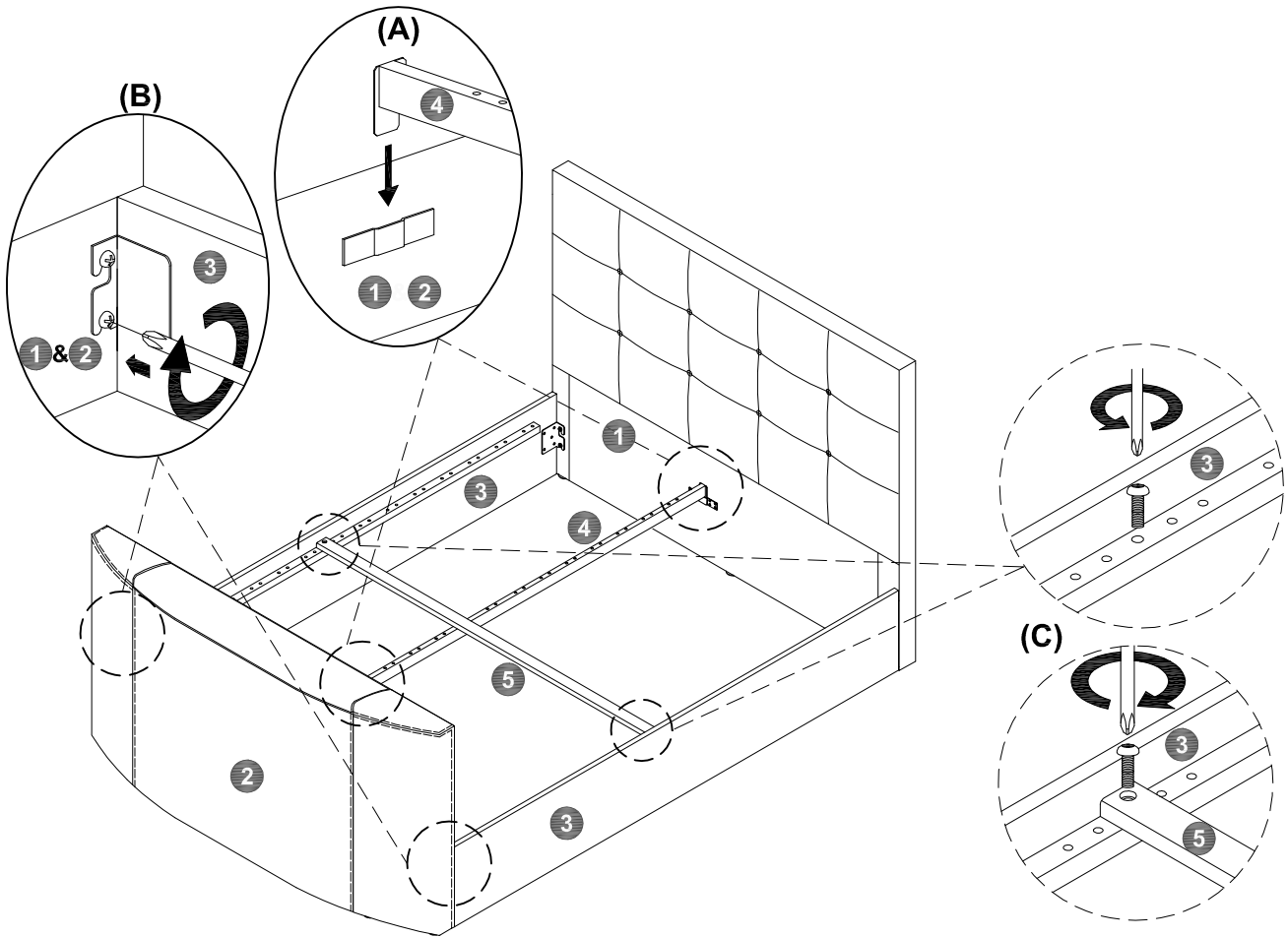

## STEP 5

- Installing Batteries in the Wireless Remote Control.

### Battery:

Size: AAA - Ø10.5 X T44.5mm

Spec.: 1.5V

(AAA) Batteries x 2pcs (provided) install to battery case.

Caution: May explode or leak if recharged, inserted improperly, mixed with different battery types. Do not open battery. Dispose of used batteries promptly. Keep away from children.

Pull out the battery case from here to open

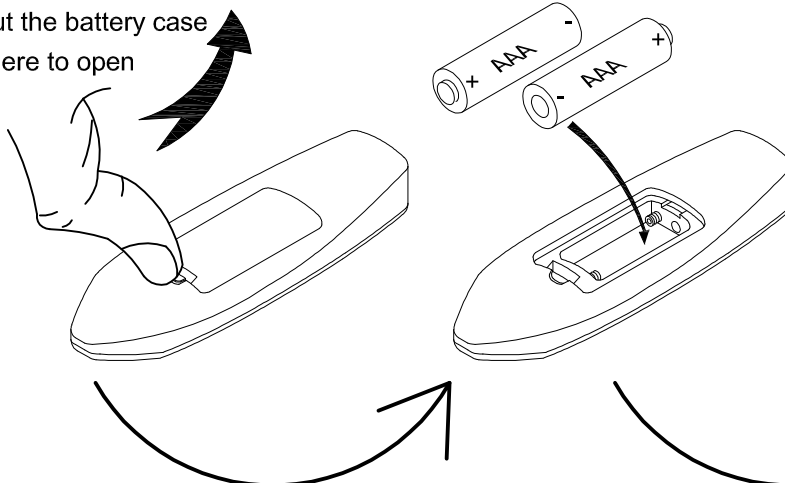

Close the battery cover and press it down until it clicks into place.

# STEP 6

- Connecting the TV mechanism cable as shown. It is essential that connecting to the power supply is done in this order. Failure to do so will result in damage to your product.
- Step 6-1 Connect the Power Cable (13) to the AC adaptor (11), then plug the AC adapter power socket into the TV mechanism power plug, which is pre-installed in the footboard, as shown.
- Step 6-2 Connect the power cable (13) power plug into an extension lead, then switch on.
- Step 6-3 Switch on the main power supply.

## STEP 1

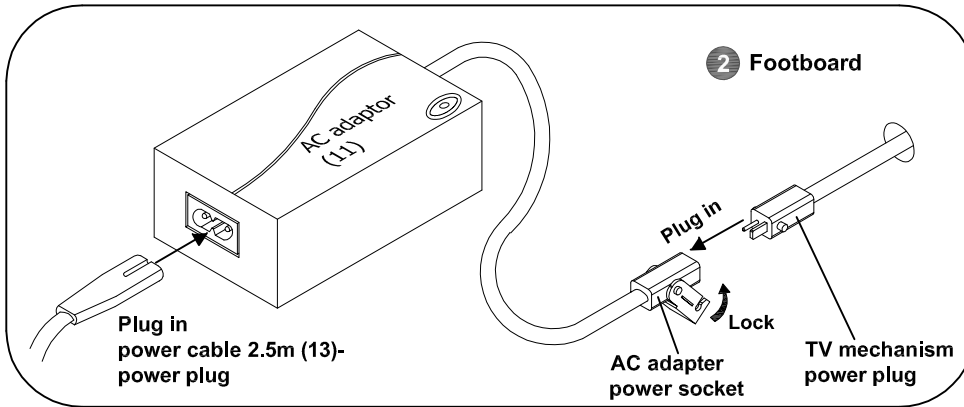

## STEP 2

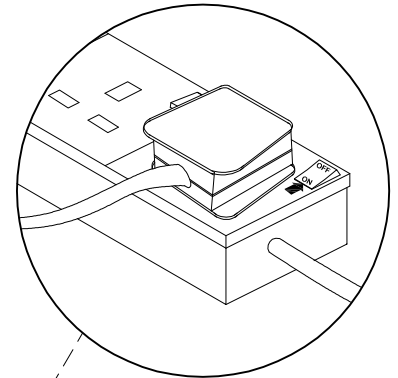

## STEP 3

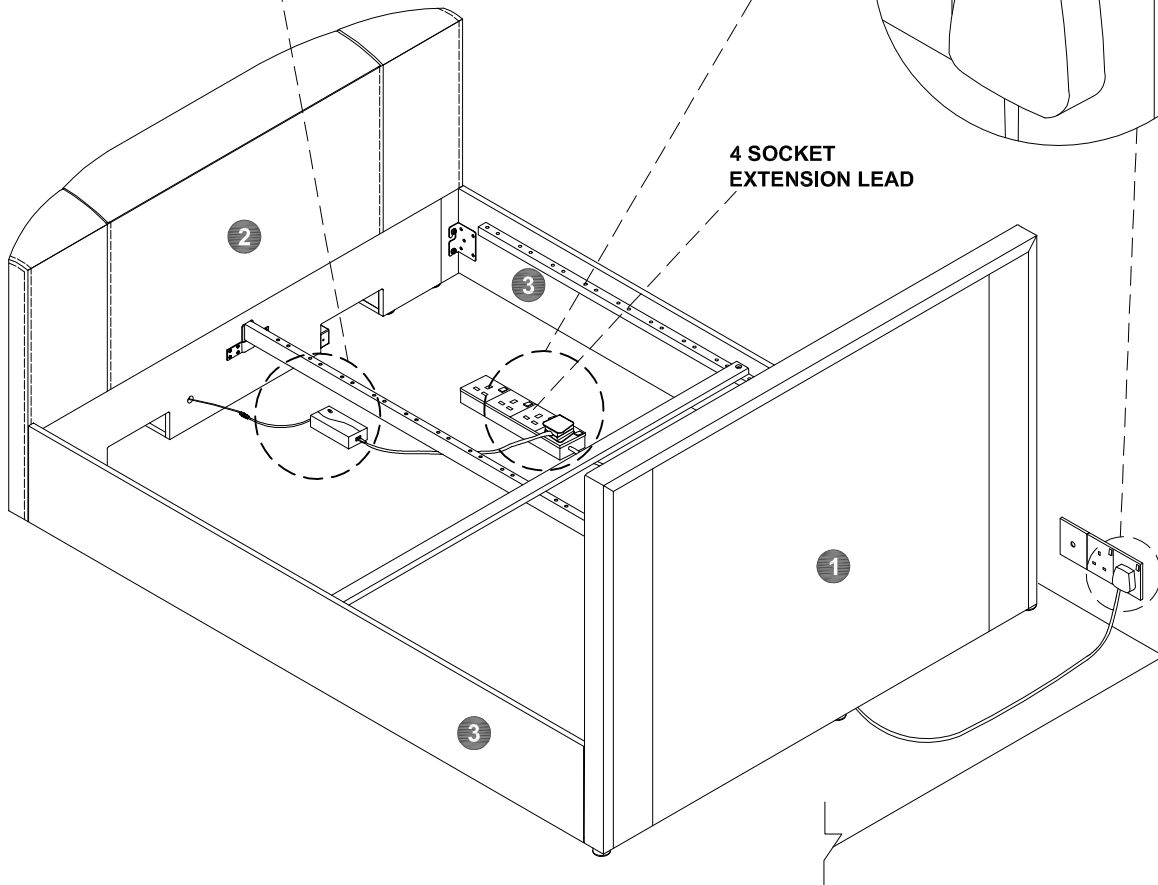
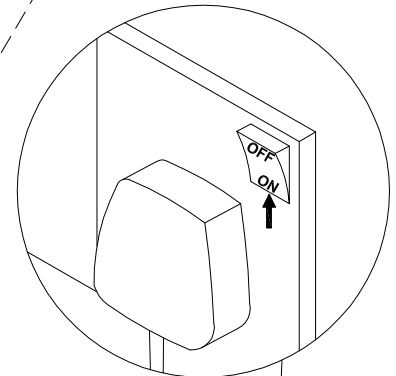

## STEP 7

- Continually press the "UP" switch on the wireless remote control, which will then lift the TV mechanism up until the footboard TV lid opens to its full extent. **Continually press the "DOWN" switch on the wireless remote control to lower the TV mechanism.**
- **If the wireless remote control does not operate the TV lift mechanism, please follow the SYNCHRONIZED SETTING shown below.**

### Wireless Remote Control

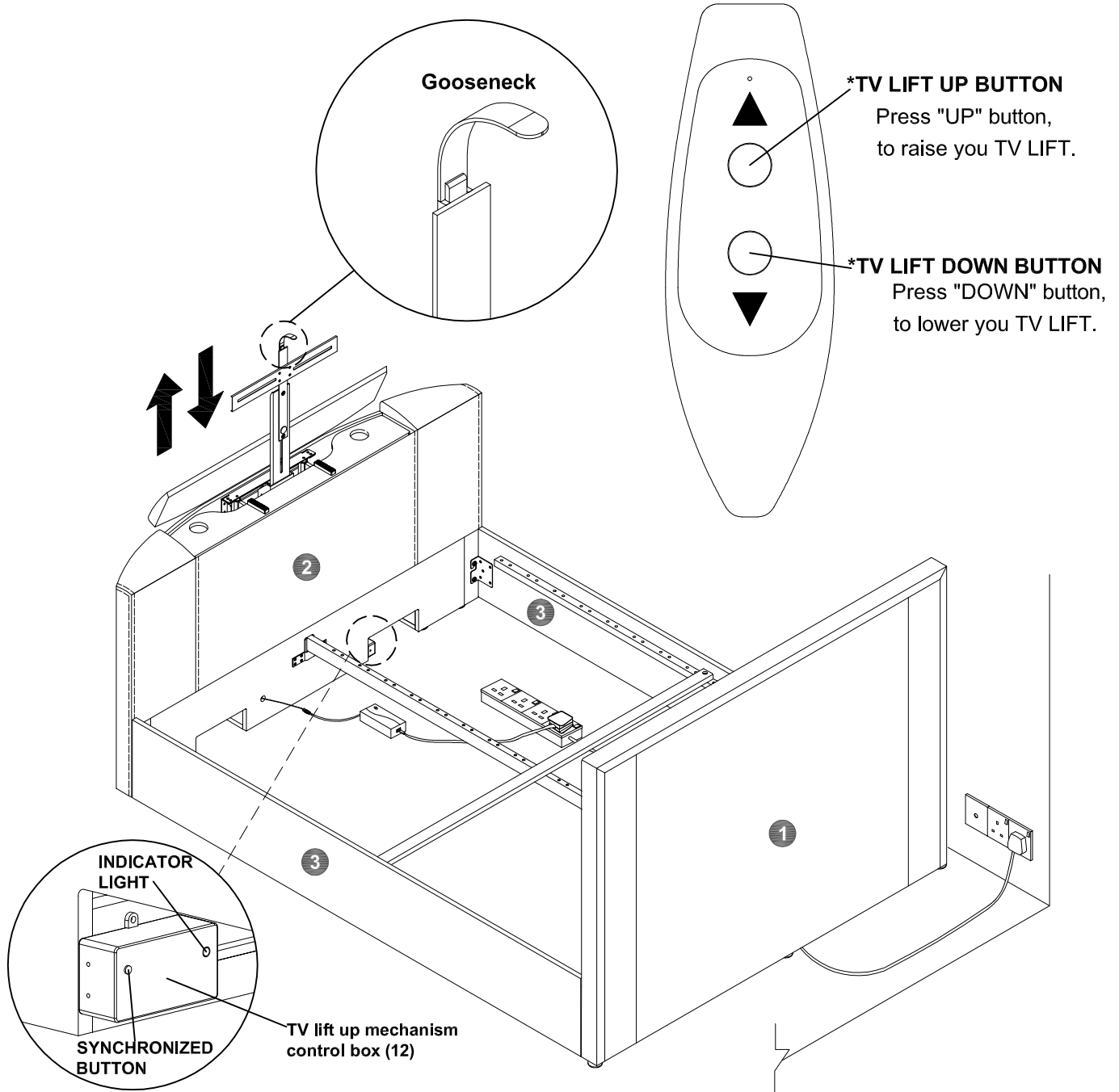

### TV LIFT MECHANISM CONTROL BOX SYNCHRONISATION

- Ensure there are two working batteries fitted correctly inside the remote control.
  - For initial start up, the wireless remote control and control box must be synchronized.
- A) Press and hold the synchronization button on the TV lift control box located in the right hand mouse hole for 3 seconds, the indicator light will flash red.
  - B) Simultaneously, press the up and down button on wireless remote control continuously for 3 seconds until the control box indicator light turns from flashing red to a static light. This means the synchronization was successful.
  - C) Now the wireless remote control is ready to use.
  - D) If the above step is not successful within 30 seconds, then the synchronization has failed and will need to be repeated.

## STEP 8

- Cable connection plan. Make sure you have all the relevant cable connections required (HDMI cable, TV Aerial cable, TV power cable, Optical cable etc...) before you install the TV.
- The cable management holes are to help you to manage the cable and keep them tidy and free from snags. Pass all cables cleanly through these holes. While ensuring any cable slack is taken up from the bottom end of the footboard.

### TIP:

Before fitting the TV, pass any cables through the cable management holes from the top to the bottom, while ensuring the cables slack is taken up from the bottom end of the footboard. choose the best side to use depending on where the connection ports are, on back of your TV.

All TV, HDMI, Aerial, optical cables MUST go through the bungee cable at the Left /Right hand side of mouse hole. From a position looking at the TV screen.

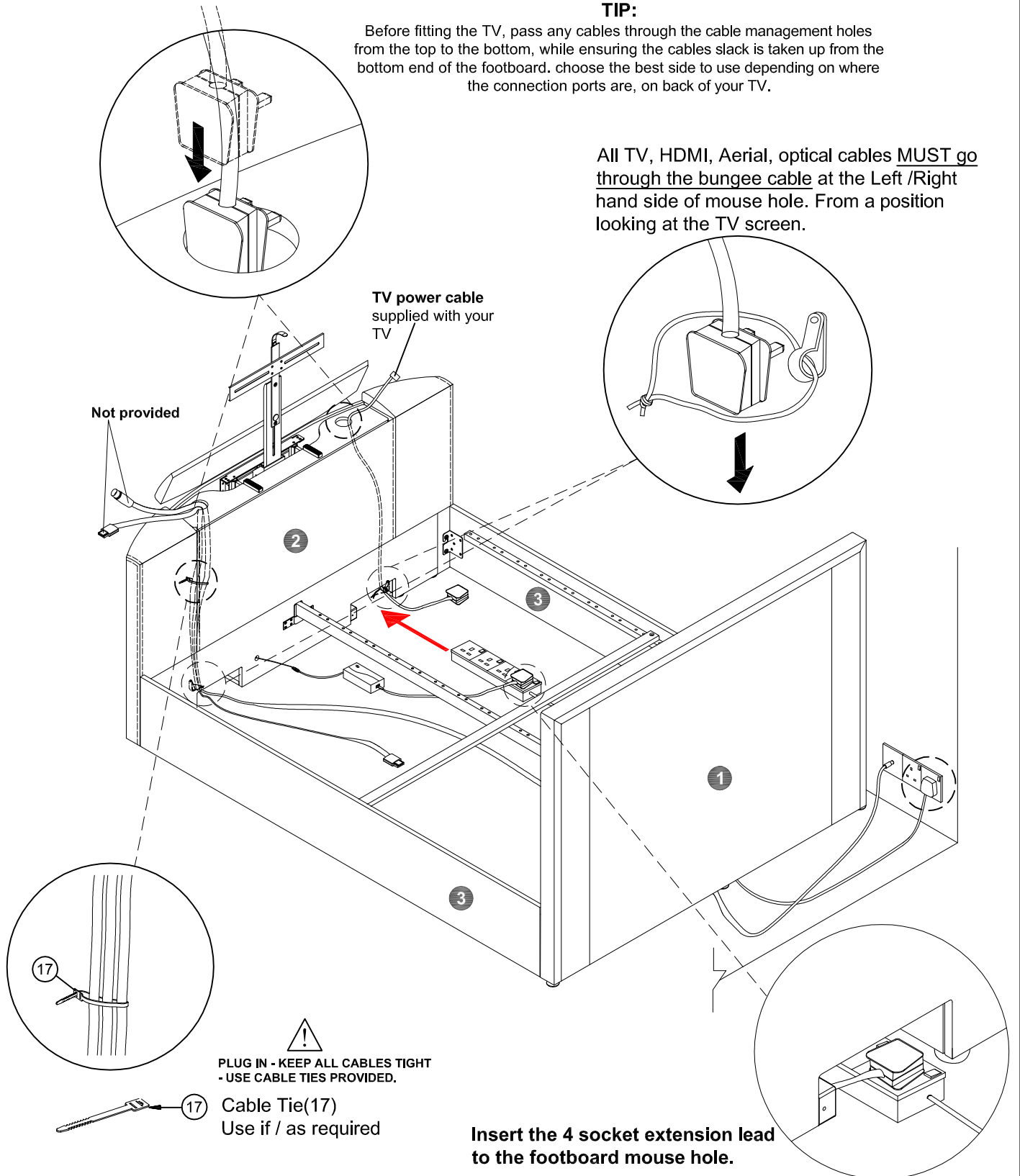

Place all cables through the 'Cable Management' holes to prevent any damage to the cable when the TV Lift Mechanism is operating. Make sure all your the cables are long enough to let the TV Lift Mechanism move freely.

All the cables MUST be carefully pulled and fully extended.

Group the cables together as required below the TV Tray using cable tie(17) provided.

## STEP 9

- Adjust the TV tray to suit the height of your TV (without stand). Please follow step below.

9.1 : Make a note of the height (without stand!) of your television.

9.2 : Use the Allen key (20) to slightly loosen the bolts-half turn only, do not remove all.  
(Please refer diagram below)

9.3 : Slide "UP/ Down the TV vertical bar to using the measure line to match the noted height of your TV, then fully tighten the bolts.

9.4 : When the TV is mounted it should sit neatly just underneath the Gooseneck.

**Note: The minimum height of the TV Tray is 440mm which accommodates any of the smaller TV heights (without stand) below 440mm.**

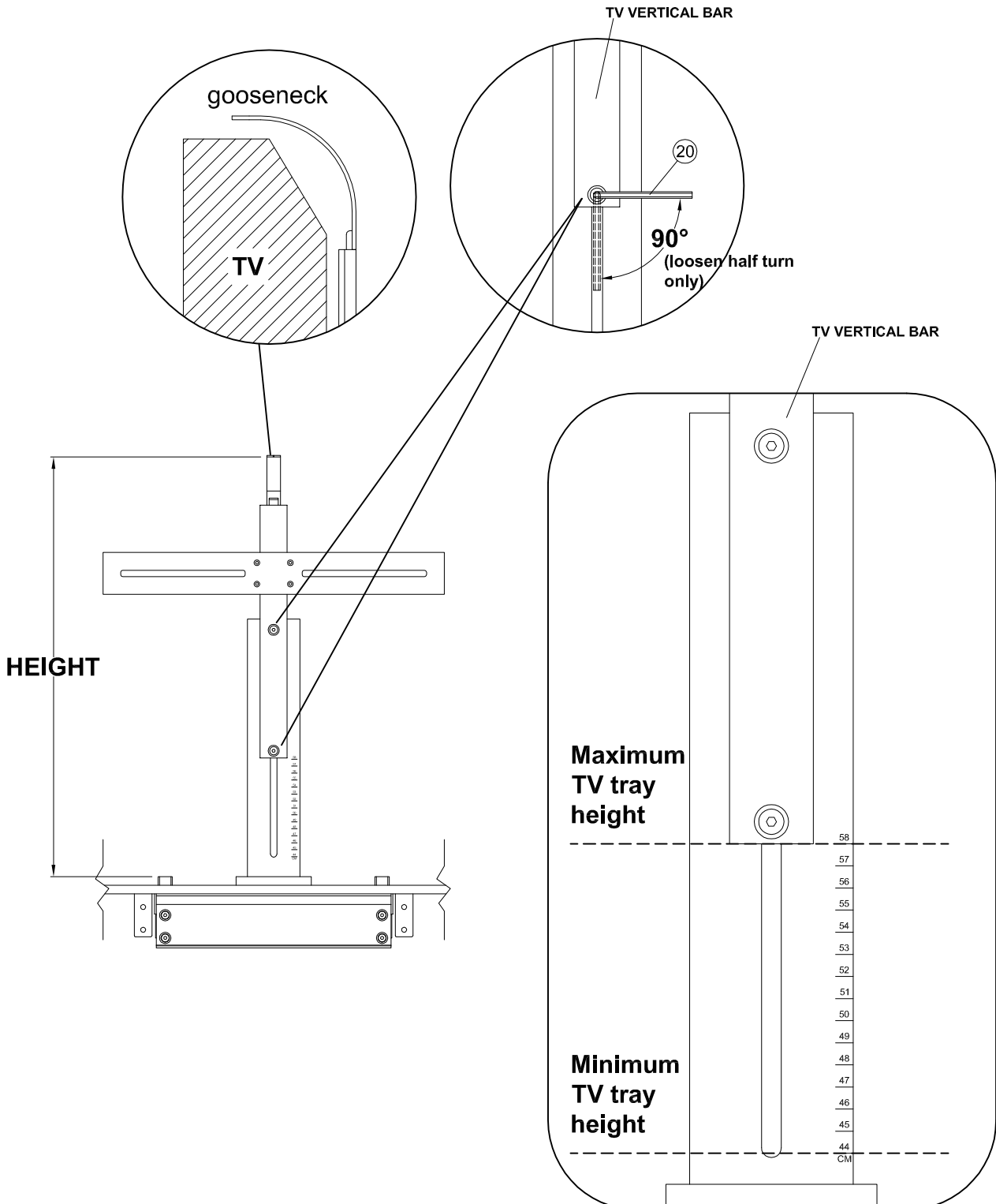

## STEP 10

- You are now ready to install your TV.
- Raise the mechanism to it's highest position.
- While standing behind your television (on the outside end of the footboard).
- Carefully place the TV on top of the two rubber TV mounting pedestals - ensuring the Gooseneck arm is perfectly inline with the horizontal 'centre' of the TV.

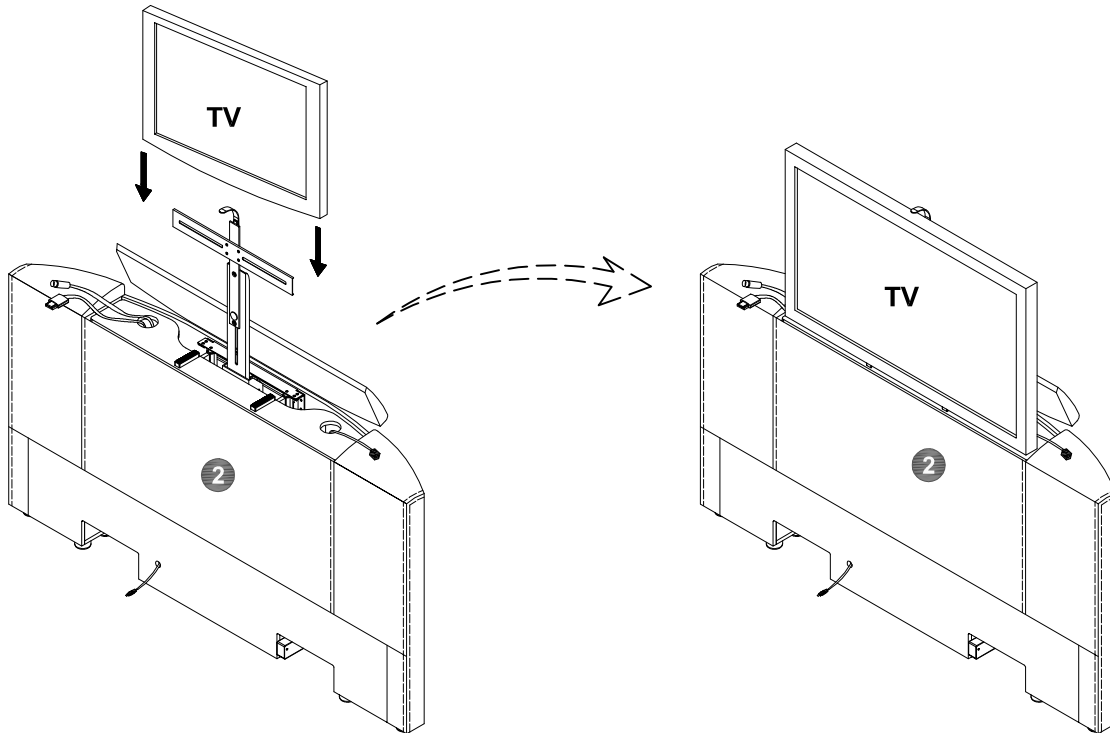

## STEP 11

- TV Flat Bracket (vesa bracket).
- Please note : Item (21) or (22) or (23) or (24) or (29) or (30) or (31) or (32) screws have been supplied to fit most TV models. However sizes may vary depending on the TV model. If smaller or larger size screws are required these should be source from your local hardware store or TV specialist. Washers may also be required. Your retailer may also supply alternative fixings depending on the TV model supplied at the time.

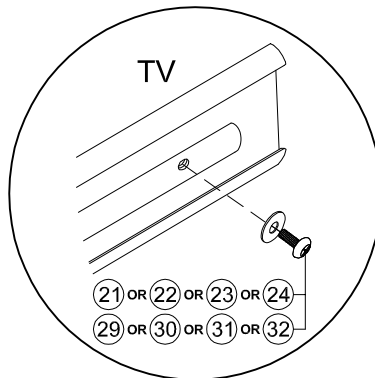
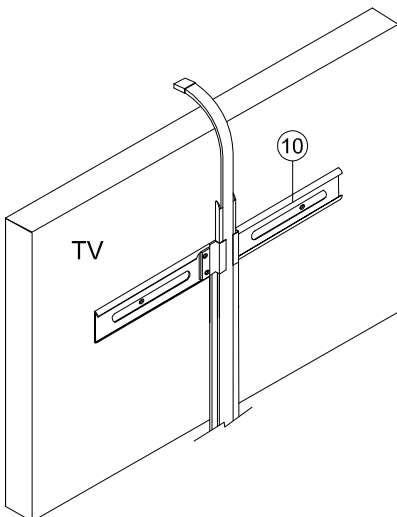

BOLT	(21)	(22)	(23)	(24)
BOLT	(29)	(30)	(31)	(32)
WITH				
WASHER	(25)	(25)	(26)	(27)

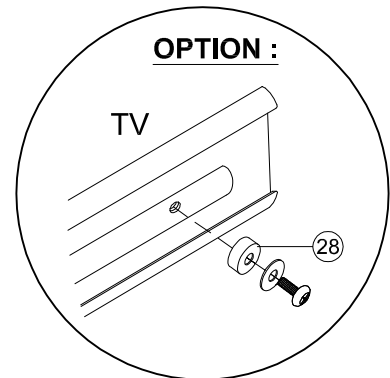

In the event you find the screws are too long for the TV with bracket please use Plastic collar (28) if required.

# STEP 12

• Install all the cable connection to the TV .

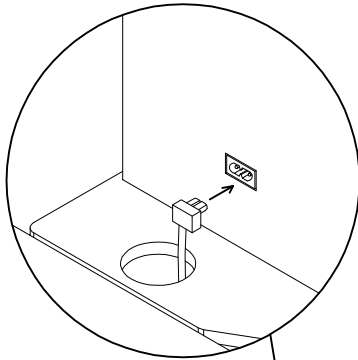

**Note: For illustration purposes only, TV connections may vary.**

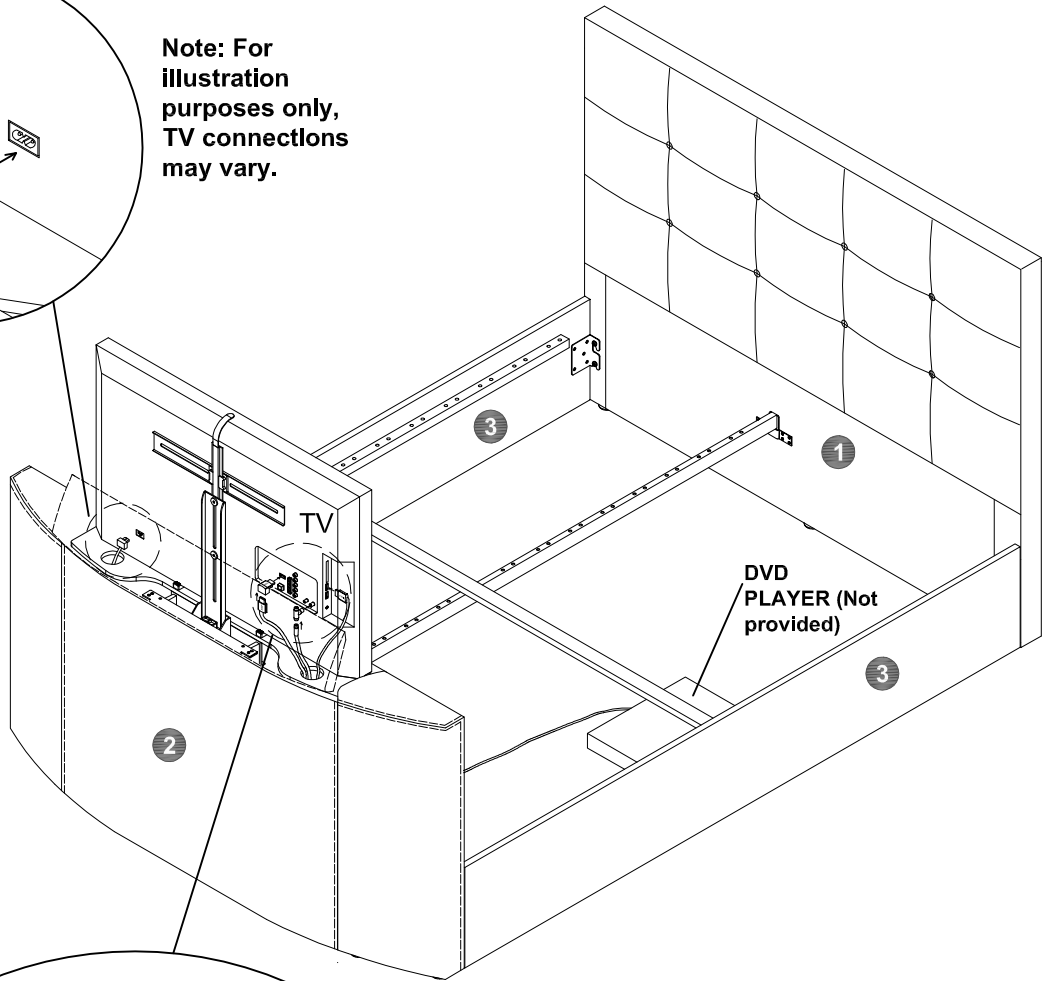

**Note: For illustration purposes only, TV connections may vary.**

YOUR TELEVISION REAR VIEW  
HDMI CABLE PLUG POSITION POSSIBLE SCENARIO'S

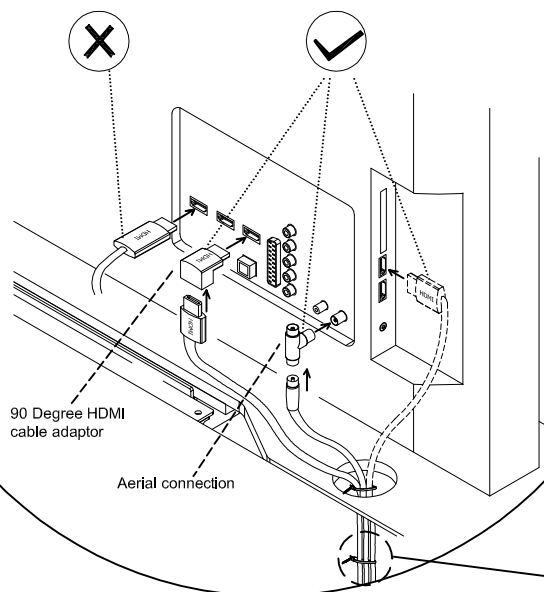

**Attention Please Note : Connecting Your HDMI or Aerial Cable as shown in diagram (X) can seriously Damage Your TV sockets.**

To reduce this possibility we have supplied 90 degree adaptors for both HDMI and Aerial connections.



This will reduce the cable protrusion and lessen the possibility of the cable colliding with the bed frame. **These can be found in the bed frame hardware pack located in Box B (foot end).** Please refer to the above diagram for the correct fitting of cables. More detailed information can also be found on above diagram of your assembly instructions.

**The manufacturer or retailer will not accept responsibility for any damages arising from incorrect installation.**



**NOTE: The cable port for television, DVD, TV aerial etc may not be the same as shown above and vary depending on TV model.**

# STEP 13

• Detail connection plan.

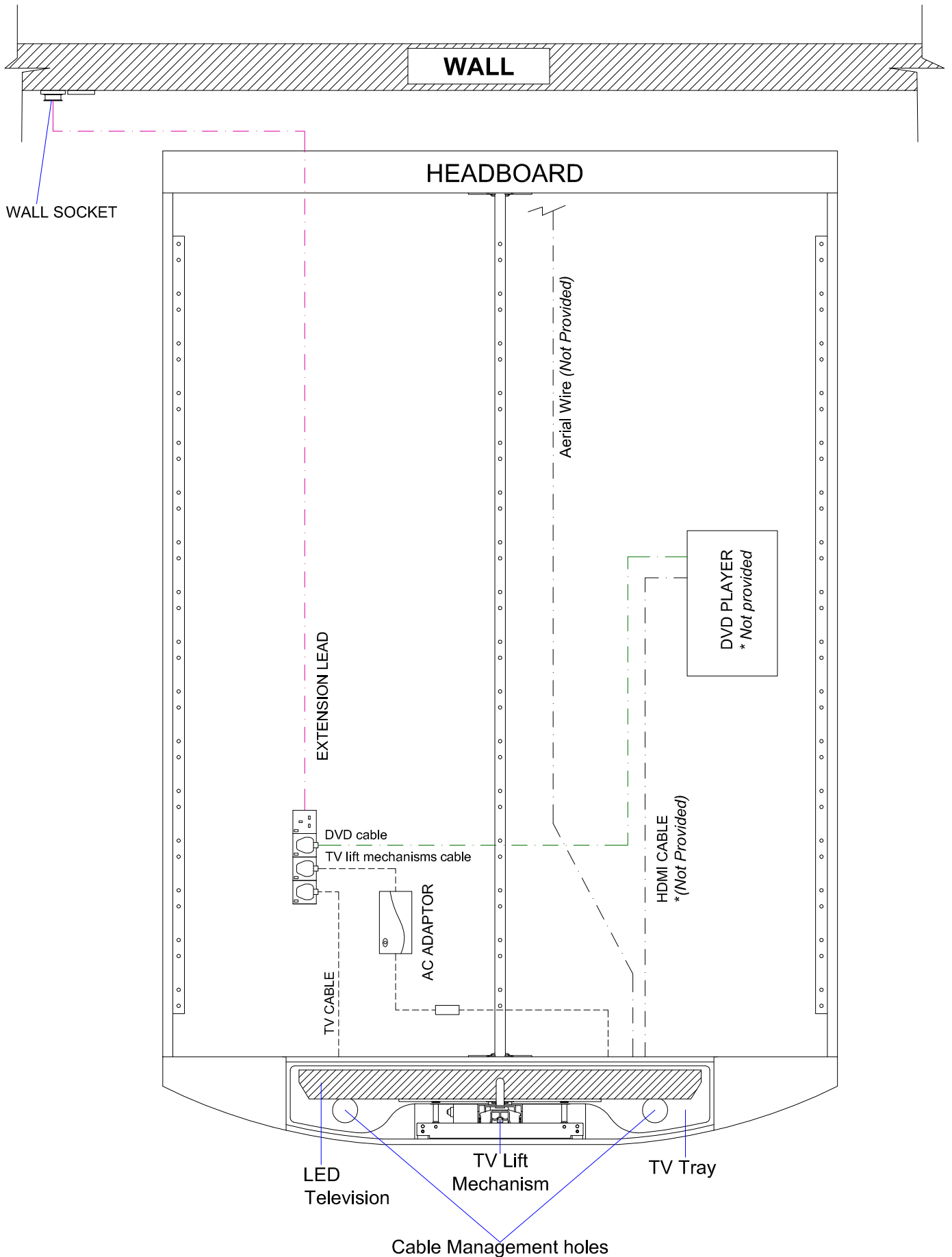

\* The TV cable main supply can be put on either the left or right side depending on the TV port location

# STEP 14

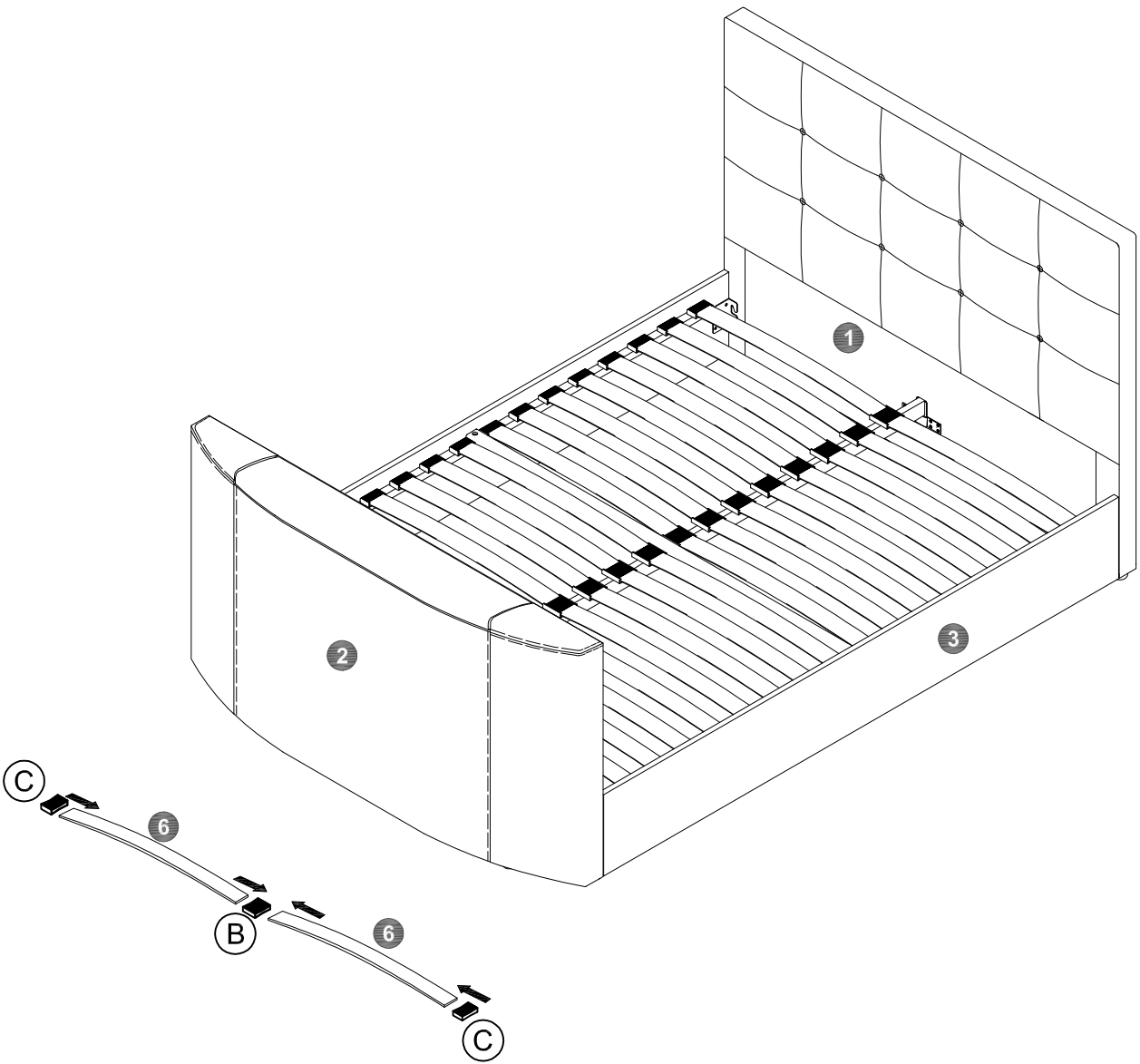
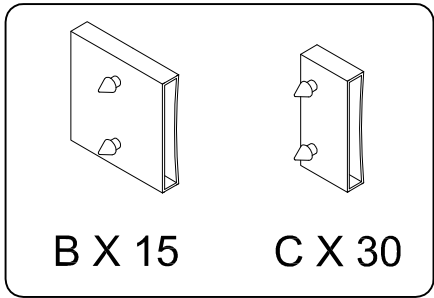

## STEP 15

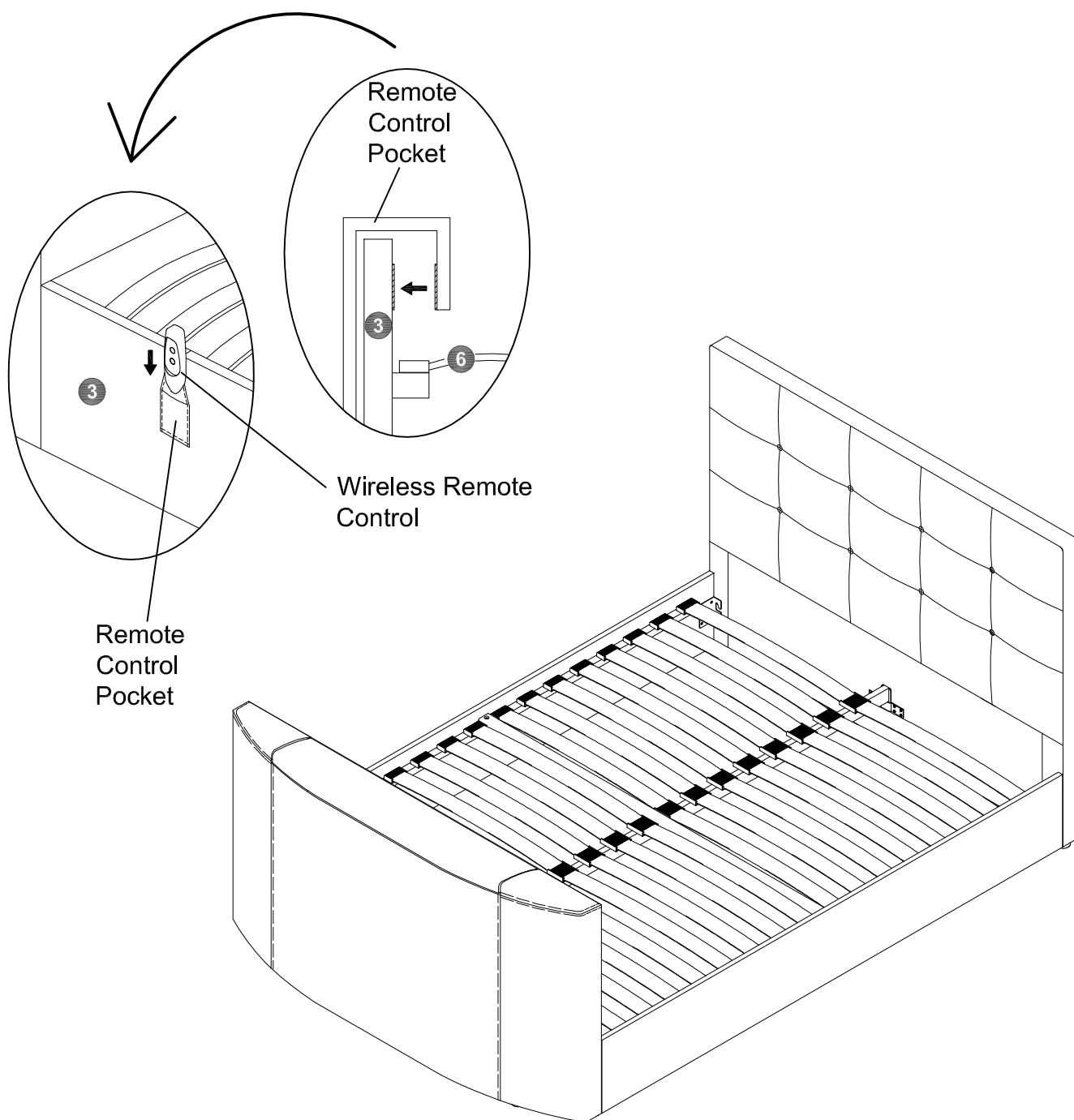

### **ATTENTION! PLEASE NOTE:**

In the event you are experiencing any technical difficulties and you require additional assistance/ support with your product 'Mechanical/ Electrical' function - Please contact:

SUPPORT EMAIL : [support@bssbfurnitureinnovation.com](mailto:support@bssbfurnitureinnovation.com)

UK PRODUCT SUPPORT HOTLINE : 01462600064

Contact your retailer for all other issues such as damage, missing or faulty components ( non electrical ) or anything else of a non technical/electrical nature.

## (DISMANTLING THE SLAT CAPS)

- Firstly, remove the end cap from the side rail support & remove one side of slats as shown.

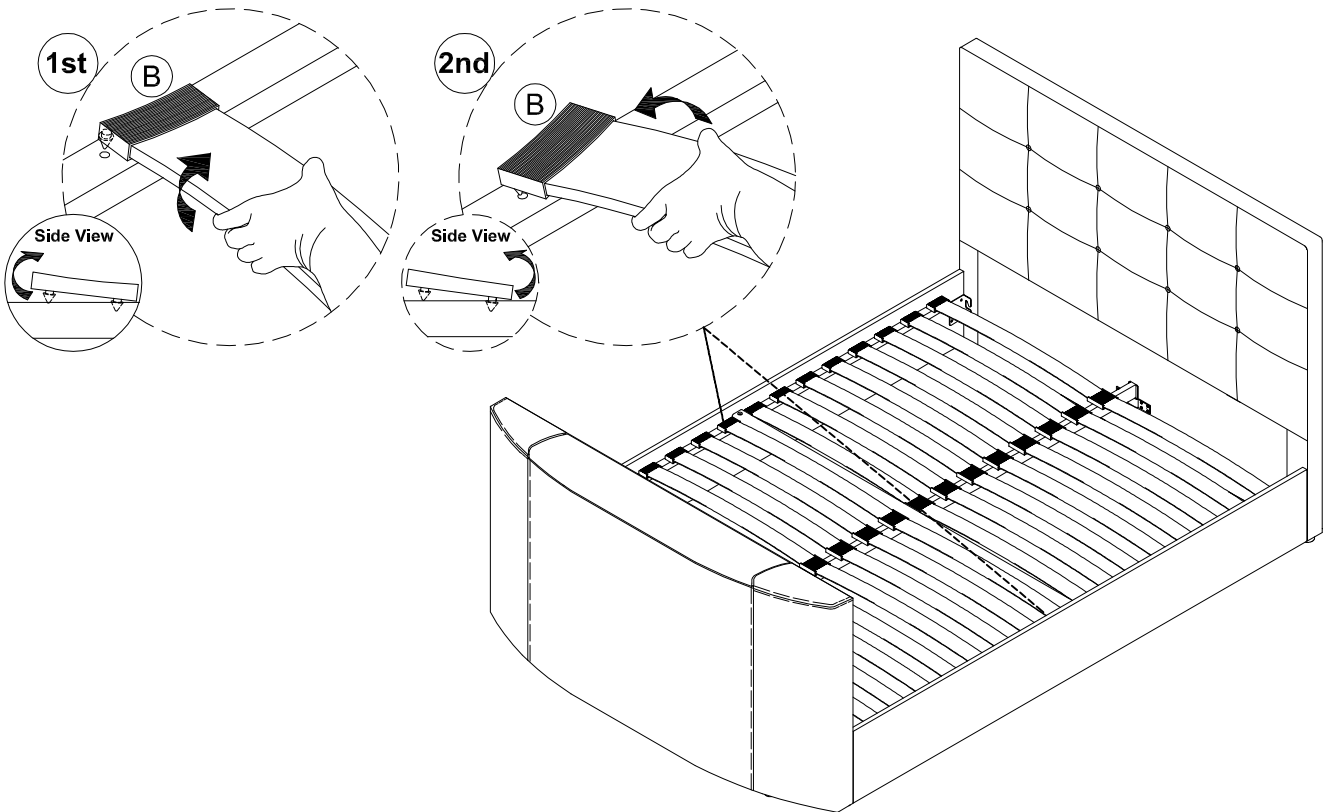

- After that, use the slats to remove middle cap slowly as shown.

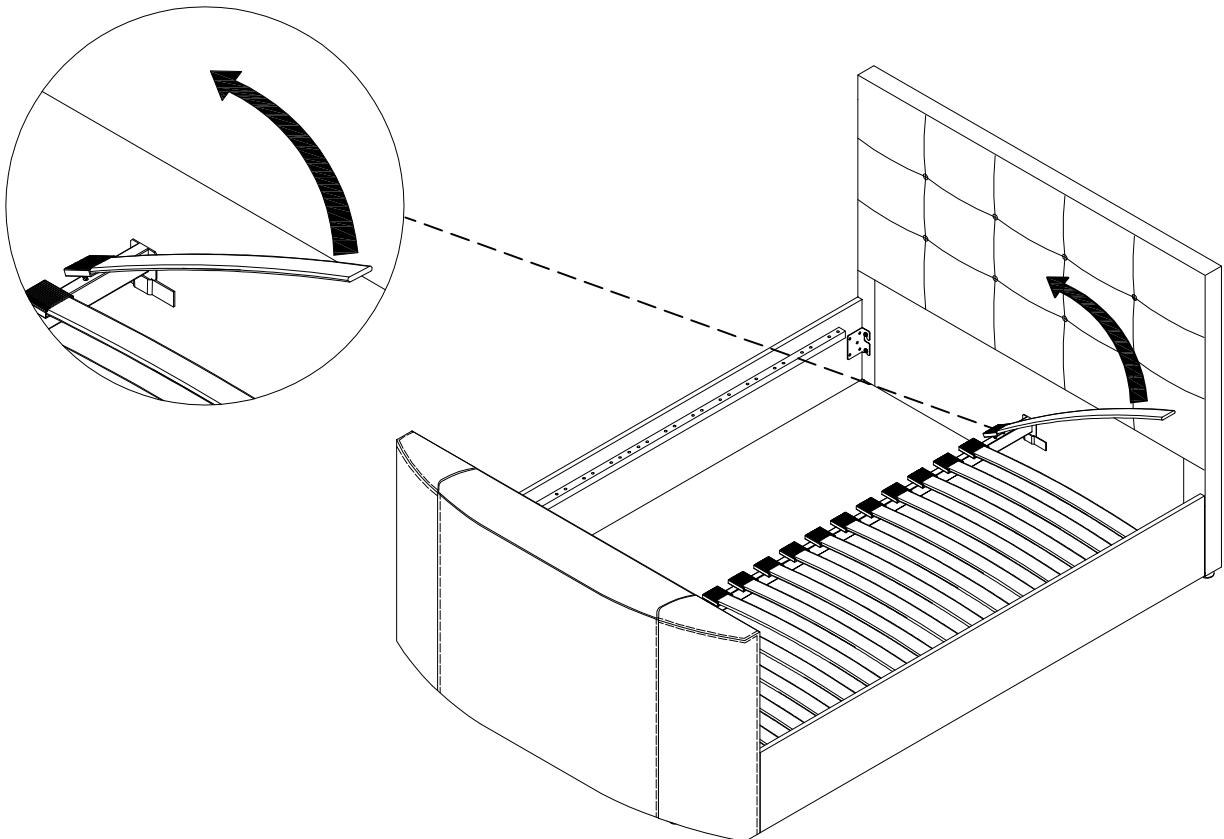

# TROUBLE SHOOTING

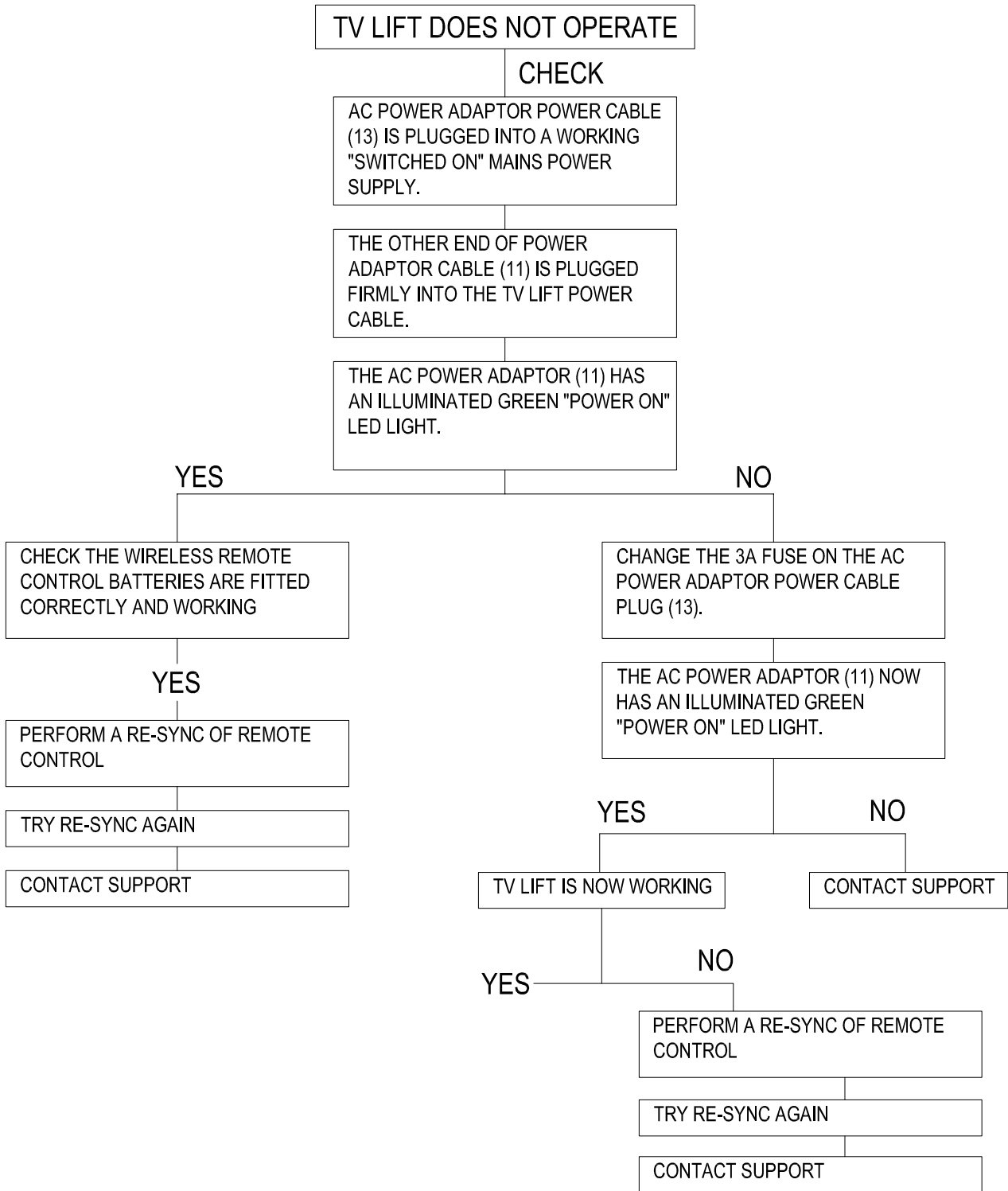

## SPECIFICATION-TV MECHANISM

FEATURE	Wireless Remote Control-TV LIFT MECHANISM
INPUT	100V-240V~ 50/60Hz 1500mA
OUTPUT	29V ---- 2A
DUTY CYCLE	MAX 10% ; MAX 2 min / 18 min
BATTERY (WIRELESS REMOTE CONTROL)	Size: AAA - Ø10.5 X T44.5mm - Spec.: 1.5V

# G4 TV LIFT MECHANISM- OPTI-SERVE SPARE PARTS LIST

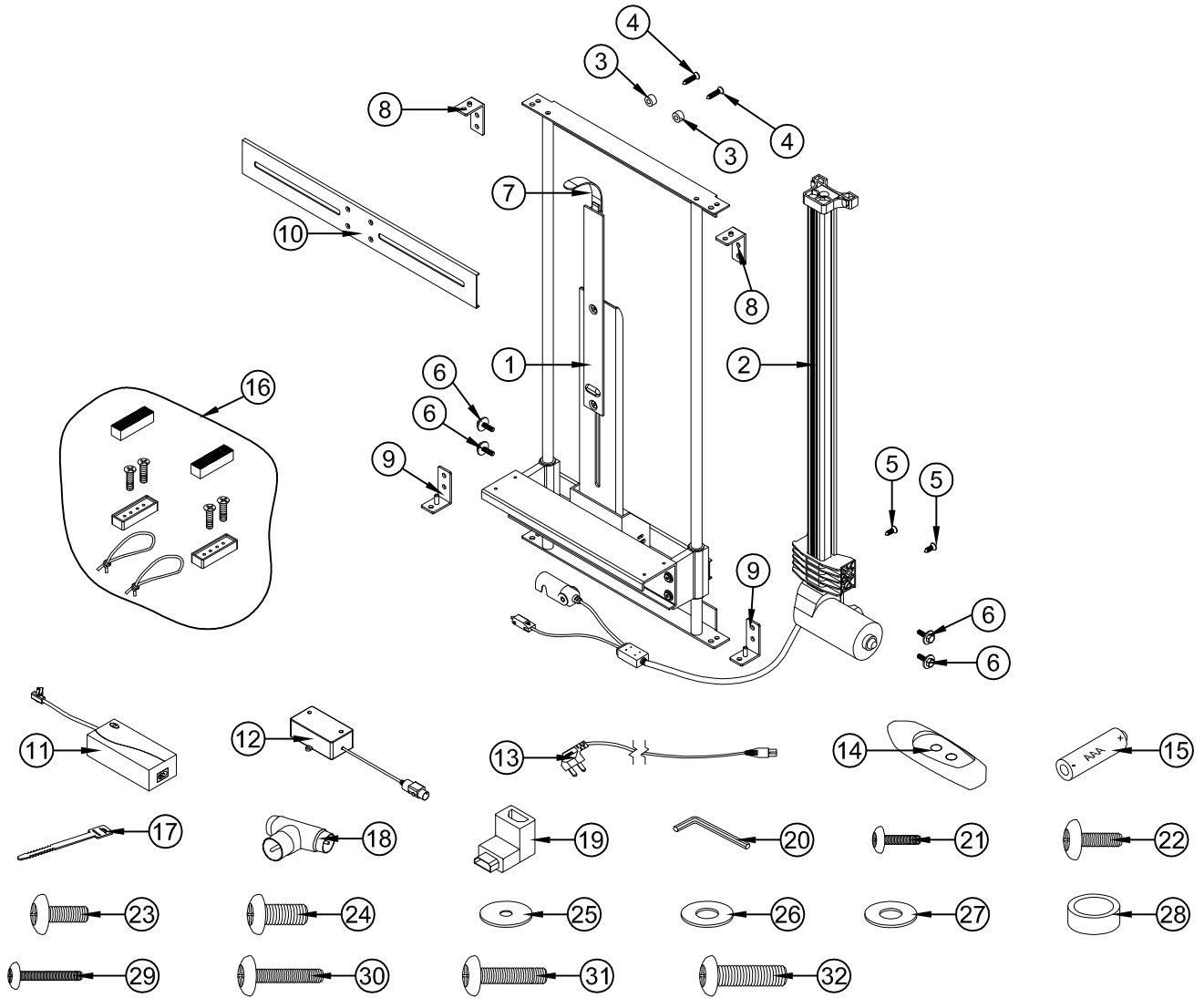

ITEM NO.	PART DESCRIPTION	IV CODES
1	Main TV-lift up mechanism (pre- assemble)	IV001281
2	TV-linear actuator G4 (pre-fixed)	
3	Actuator mounting top spacer (2pcs) (pre-fixed)	
4	Cross recessed countersunk flat head wood screw- Top mounting M6 x 30mm (2pcs) (pre-fixed)	IV001282
5	Cross recessed countersunk flat head wood screw- Top mounting M6 x 20mm (2pcs) (pre-fixed)	
6	Actuator mounting bolt- screw M6 x 20mm (4pcs) (pre-fixed)	
7	Gooseneck (pre-fixed)	IV001289
8	Top hanging bracket (2pcs) (pre-fixed)	
9	Bottom hanging bracket (2pcs) (pre-fixed)	IV001636
10	TV- flat bracket (Vesa Bracket) (pre-fixed)	IV001290
11	TV-lift up mechanism AC/ DC adapter	IV001291
12	TV lift-up mechanism control box (pre-fixed)	IV001293
13	TV-lift up mechanism AC/ power-cable power plug UK	IV001295
14	Wireless remote control	IV001302
15	Battery (2pcs)	IV000991
16	TV block (2pcs), screw M4 x 35mm (4pcs), block rubber cover (2pcs), cable management bungee cable (2pcs) (pre-fixed)	IV001635
17	Cable clip (2pcs)-use to fix wire	
18	Aerial connection (1pc)	
19	90 degree HDMI adaptor (1pc)	
20	Allen key (M4) (1pc)	
21	Pan head screw M4 x 20mm (2pcs)	
22	Pan head screw M5 x 20mm (2pcs)	
23	Pan head screw M6 x 20mm (2pcs)	
24	Pan head screw M8 x 20mm (2pcs)	
25	M5 washer (2pcs)	
26	M6 washer (2pcs)	
27	M8 washer (2pcs)	
28	Plastic collar (6pcs)	
29	Pan head screw M4 x 40mm (2pcs)	
30	Pan head screw M5 x 40mm (2pcs)	
31	Pan head screw M6 x 40mm (2pcs)	
32	Pan head screw M8 x 40mm (2pcs)	IV001634

Please dispose of all packaging safely.

## General Care & Maintenance

Wipe clean with a slightly damp cloth.  
Avoid the use of all household cleaners and abrasives.

Periodically check all screw & fixings to ensure they are secure.  
When moving your product, carefully lift into place. Never drag or push the product across the floor as this will cause damage to the joints. If the product is used on hard flooring, such as wood or laminated floor, you must place some protection under the legs to stop the product from moving. If this is not adhered to, it could result in failure to the product that will invalidate the warranty.

For more information on cleaning and product care visit:  
<https://www.happybeds.co.uk/help-and-advice>

## Notes

We've tried to make this product as easy to assemble as possible. In the unlikely event that you have problems putting it together or have damaged or missing pieces, please contact us by visiting:

<https://www.happybeds.co.uk/customer-service>



[www.happybeds.co.uk](http://www.happybeds.co.uk)

