

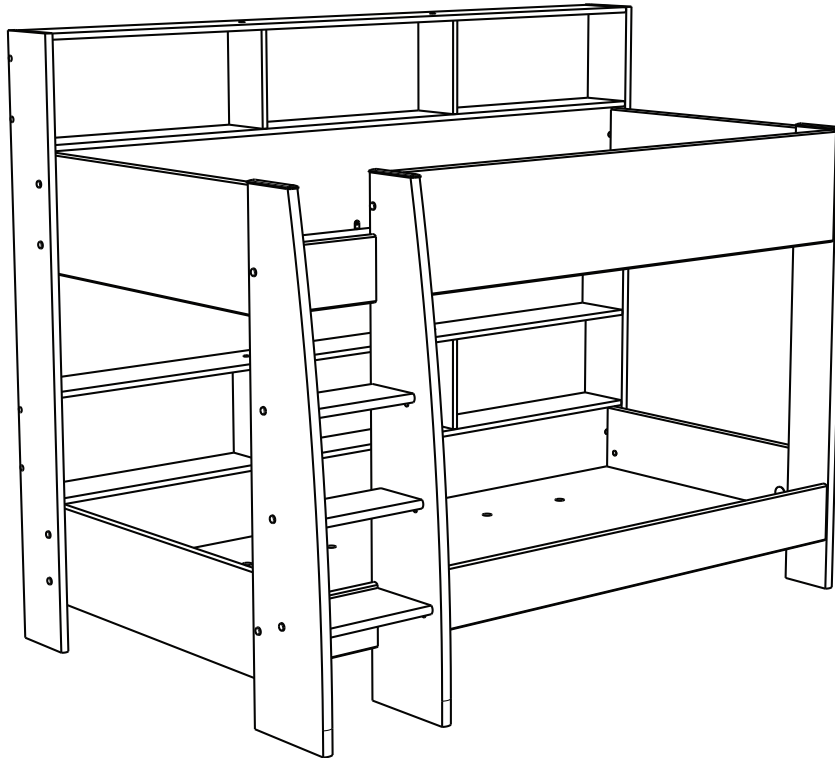

Assembly Instructions

Tam Tam Wooden Bunk Bed



Important before assembly:

Read these instructions carefully before assembling or using the product.

Please check the contents of the boxes before attempting to assemble this product. The instructions will have a checklist of parts and fittings.

It would be sensible to lay a rug or a carpet on the floor where you intend to assemble the product, to void scratches and damaging the product or the floor.

Assemble the product as close to its intended final location/room as possible.

Do NOT use any power tools as this may damage the frame.

Health & Safety:

This product or some parts of this product will be heavy. Please use an assistant when lifting.

DO NOT jump on the product or any of its parts.

DO NOT use this product if any parts are missing, damaged or worn.

DO NOT use this product unless all fixings are secured.

Please keep small parts out of reach of children.

Always use on a level, even surface.

Please keep these instructions for future reference.



(Not metal)

These tools are not necessary, but may help to assemble certain parts of the product.

Do NOT use any power tools as this may damage the frame.

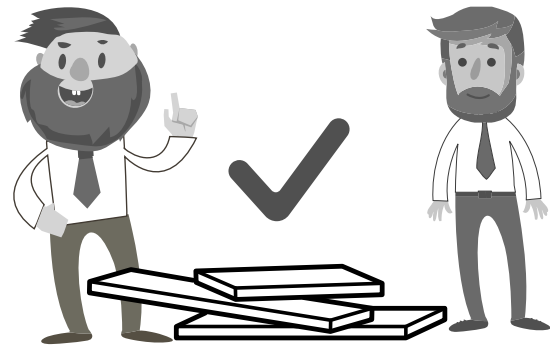
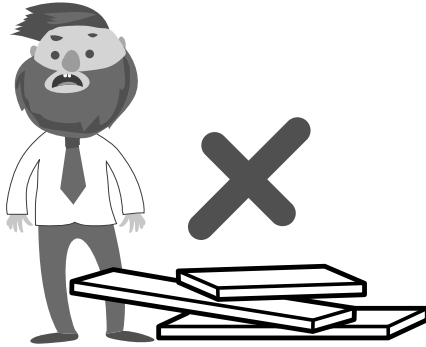

This product or some parts of this product will be heavy. Please use an assistant when lifting.

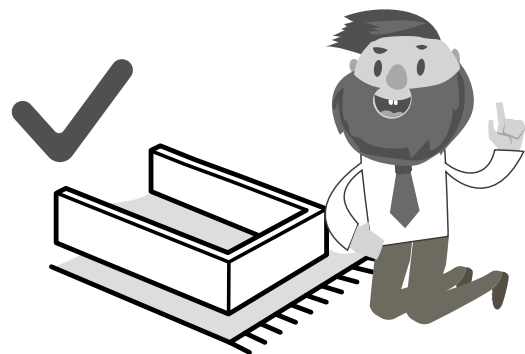

Never drag or push the pieces across a hard or stone floor as this will cause damage to the joints. Use a carpet or a rug for extra care.

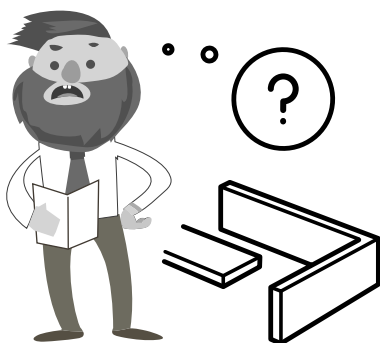

If you have problems assembling or have damaged or missing pieces, please contact us by visiting:

<https://www.happybeds.co.uk/customer-service>



Important for High Sleepers, Bunk Beds and Children's Beds

Warning:

High sleepers and the upper tier of bunk beds are not suitable for children under 6 years of age due to risk of injury from falls.

High Sleepers and Bunk Beds present a risk of injury from strangulation if used incorrectly. Never attach or hang anything on any part of the bed that is not designed to be used with the bed, for example, but not limited to ropes, strings, cords, hooks, belts and bags.

Children can become trapped between the bed and the wall, a roof pitch, the ceiling and other pieces of furniture (e.g. wardrobes). To avoid risk of serious injury, the distance between the top safety barrier and any adjoining structure shall not exceed 75mm or shall be more than 230mm.

Maximum thickness of a mattress on the top tier is 18cm. Please refer to the label or marking on the headboard.

This bed has been tested by an independent laboratory and is in compliance with BS EN 747-1 : 2012+A1:2015 - Standard Consumer Safety specification for bunk beds & high sleepers.

2344LISU

LE COUCHAGE EN HAUTEUR NE CONVIENT PAS
AUX ENFANTS DE MOINS DE 6 ANS

~~G~~ THIS BED DOES NOT FIT

CHILDREN UNDER 6 YEARS OLD

~~D~~IE HOHE DER LIEGEFLACHE IST NICHT GEEIGNET
FÜR KINDER UNTER 6 JAHREN

~~E~~N LAS LITERAS LA CAMA SUPERIOR NO CONVIERNE
A LOS MINOS MENORES DE 6 AÑOS

~~P~~AMA E ALTURA MAO CONVEM

AS CRIANÇAS DE MENOS DE 6 ANOS

~~I~~ PETTO IN ALTEZZA NON CONVIERNE
A BAMBINI SOTTO 6 ANNI

~~N~~ESE HOOGSTAPER IS NIET GESCHIKT
SOOR KINDEREN MINDER DAN 6 JAAR

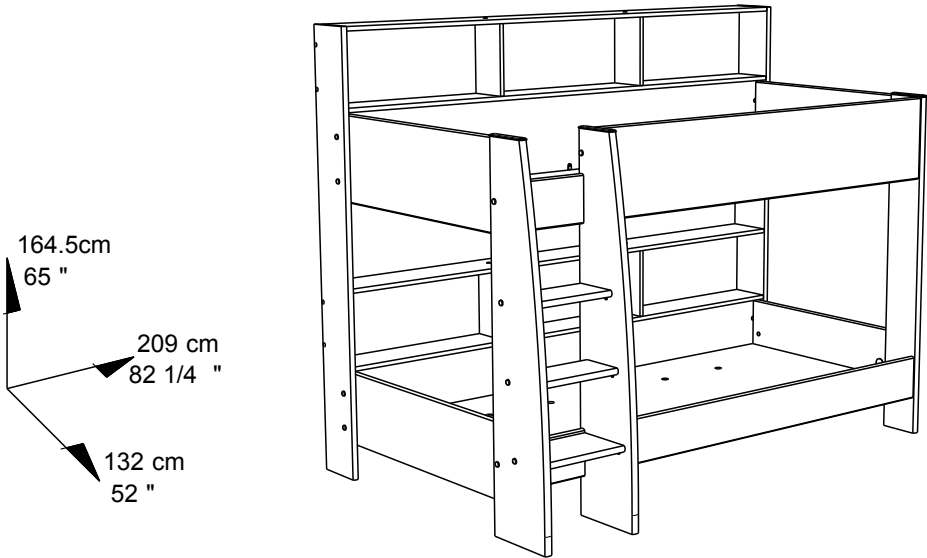

164.5cm
65 "
209 cm
82 1/4 "
132 cm
52 "

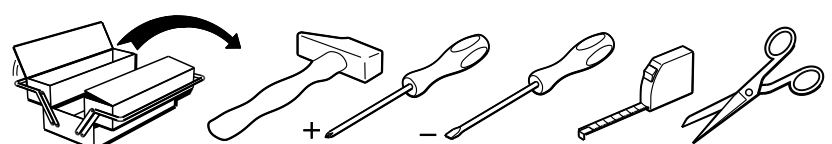
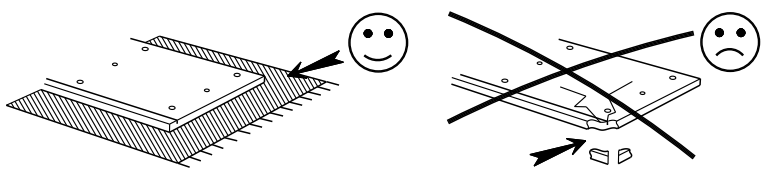

F. Instructions d'utilisation

IMPORTANT – LIRE ATTENTIVEMENT – A CONSERVER POUR REFERENCE ULTERIEURE

1. Utiliser les outils indiqués sur la notice de montage et suivre les instructions d'assemblage.
2. Il convient que tous les dispositifs d'assemblage soient toujours convenablement serrés et régulièrement vérifiés, ainsi que resserrés si nécessaire.
3. Le positionnement et le moyen d'accès au lit sont indiqués sur la notice de montage.
4. Respecter l'épaisseur maximale du matelas, voir le marquage sur la notice de montage.
5. Taille du matelas recommandé 1980 X 880 X 150 maximum.
6. Il convient de ne pas utiliser le lit surélevé lorsqu'une partie de la structure manque ou est cassée.
7. Les lits surélevés ne conviennent pas aux enfants de moins de 6 ans, en raison des risques de blessures dues aux chutes.
8. Attention aux articles tels que des cordes, des ficelles, des cordons, des harnais et des ceintures attachés ou accrochés sur un lit superposé ou surélevé afin d'éviter aux enfants de s'étrangler.
9. Avertissement «Les enfants peuvent se retrouver piégés entre le lit et le mur. Pour éviter le risque de blessure grave la distance entre la barrière de sécurité supérieure et le mur ne doit pas excéder 75 mm ou doit être d'au moins 230 mm»
10. Conforme à la norme européenne EN747-1 de 2007.
11. Ne jamais laisser des enfants sans un minimum de surveillance.
12. Aucun jeu brutal ne doit être permis dans et sous le lit haut.
13. Il est interdit d'avoir plus d'une personne dans le lit haut.
14. Ne pas permettre aux enfants de se basculer ou de sauter sur ou sous le lit.
15. Utiliser toujours l'échelle pour monter ou descendre du lit haut.
16. Ne pas remplacer les pièces originales par des substitutions. Obtenir les pièces de rechange du magasin ou du fabricant.
17. L'utilisation d'une veilleuse de nuit peut procurer plus de sécurité à l'enfant couchant dans le lit haut.

GB. Instructions for use

IMPORTANT – PLEASE READ CAREFULLY – KEEP FOR FUTURE REFERENCE

1. Use the tools indicated on the assembly leaflet and follow the instructions.
2. All assembly components must always be tightened properly. Check regularly and retighten if necessary.
3. The positioning and means of access to the bed are indicated on the assembly leaflet.
4. Do not exceed the maximum mattress thickness. Refer to the marking on the assembly leaflet.
5. Maximum recommended mattress size: 1980 X 880 X 150
6. The high sleeper must not be used if a part of the structure is missing or broken.
7. High sleepers are not suited to children below the age of 6 years due to the risk of injury in the event of a fall.
8. Do not attach or suspend items such as ropes, strings, cords, harnesses and belts on a bunk-bed or high sleeper to avoid the possibility of strangulation.
9. Warning: Children may become trapped between the bed and the wall. To avoid the risk of serious injury, the distance between the top safety barrier and the wall must not exceed 75 mm or must be at least 230 mm.
10. Compliant with European Standard EN 747-1 of 2007.
11. Never leave children without a minimum of supervision.
12. Children must not be allowed to play roughly on or under the top bunk.
13. It is forbidden to have more than one person in the top bunk.
14. Do not allow children to swing or jump on or under the bed.
15. Always use the ladder to climb up to and down from the top bunk.
16. Do not replace original parts with substitutes. Spare parts must be obtained from the store or manufacturer.
17. Use of a night-light will improve safety for a child sleeping in the top bunk.

D. BENUTZUNGSHINWEISE

WICHTIG – AUFMERKSAM LESEN – FÜR EINE SPÄTERE EINSICHT AUFBEWAHREN

1. Die in der Montageanleitung angeführten Werkzeuge benutzen, die Montagehinweise beachten.
2. Alle Elemente müssen korrekt verbunden und angezogen (notfalls nachziehen) sein und regelmäßig überprüft werden.
3. Die Position und der Zugang zum Bett sind in der Montageanleitung aufgeführt.
4. Die maximale Stärke der Matratze einhalten, siehe die Markierungen in der Montageanleitung.
5. Empfohlene Abmessungen der Matratze 1980 X 880 X 150 maximal
6. Das Etagenbett darf nicht benutzt werden wenn die Struktur oder ein Teil der Struktur fehlt oder beschädigt ist.
7. Die Etagenbetten sind nicht für Kinder unter 6 Jahren geeignet (Verletzungs- –und Unfallgefahr)
8. Vorsicht ist weiterhin geboten mit am Etagenbett befestigten Seilen, Kordeln, Bändern, oder Sicherheitsgeschirr, hier besteht Strangulierungsgefahr für Kinder.
9. Warnung « Kinder können sich zwischen dem Bett und der Wand eingeklemmt finden. Um Unfälle zu vermeiden, darf der Abstand zwischen der oberen Sicherheitsleiste und der Wand nicht mehr als 75 mm betragen oder muß wenigstens 230 mm betragen.
10. Entsprechend der europäischen Norm NF EN747-1 von 2007
11. Kinder niemals ohne ein Minimum von Aufsicht lassen.
12. Brutale Spiele dürfen in oder auf dem oberen Bett nicht zugelassen werden.
13. Im oberen Bett darf nur eine Person schlafen.
14. Die Kinder dürfen nicht auf das Bett springen oder schaukeln.
15. Nur die Leiter zum Hinaufsteigen und Herabsteigen des oberen Bettes benutzen.
16. Nur Originalteile bei Reparaturen verwenden. Die Austauschteile nur im Fachhandel oder beim Hersteller einkaufen.
17. Die Benutzung einer kleinen Lampe kann dem Kind im oberen Bett ein Sicherheitsgefühl verleihen.

I. Istruzioni d'uso

IMPORTANTE – LEGGERE ATTENTAMENTE – CONSERVARE PER FUTURA CONSULTAZIONE

1. Utilizzare gli utensili indicati sull'avviso di montaggio e seguire le istruzioni per l'assemblaggio.
2. È necessario che tutti i dispositivi di assemblaggio siano sempre opportunamente stretti e regolarmente controllati, nonché stretti nuovamente, se necessario.
3. La collocazione e il mezzo di accesso al letto sono indicati sull'avviso di montaggio.
4. Rispettare lo spessore massimo del materasso, facendo attenzione alla marchiatura sull'avviso di montaggio.
5. Misura consigliata di materasso 1980 X 880 X 150 massimo.
6. Si sconsiglia l'uso del lettino sopraelevato se una parte della struttura manca o è rotta.
7. I lettini sopraelevati non sono adatti a bambini di età inferiore ai 6 anni, per i rischi di lesioni dovuti a cadute.
8. Attenzione agli articoli quali corde, spaghi, cordoni, imbracature o cinture fissate o appese a un letto sovrapposto o sopraelevato, per evitare che i bambini possano strangolarsi.
9. Avvertenza: "I bambini possono trovarsi intrappolati tra il letto ed il muro. Per evitare il rischio di gravi lesioni, la distanza tra la barriera di sicurezza superiore e il muro non deve superare i 75 mm o deve essere almeno di 230 mm".
10. Conforme alla norma europea EN747-1 de 2007.
11. Non lasciare mai i bambini senza un minimo di sorveglianza.
12. Non permettere alcun gioco violento sul letto alto e al di sotto di esso.
13. È vietata la presenza di più di una persona sul letto in alto.
14. Non lasciare che i bambini si dondolino o che saltino sul letto o sotto di esso.
15. Per salire sul letto in alto o per scendere da esso, servirsi sempre della scaletta.
16. Non sostituire i componenti originali con parti non originali. Procurarsi i componenti di ricambio presso il magazzino o presso il produttore.
17. L'utilizzo di una lucetta notturna può offrire maggiore sicurezza al bambino che dorme sul letto in alto.

E. Instrucciones de utilización

IMPORTANTE – LEER ATENTAMENTE – CONSERVAR PARA REFERENCIA ULTERIOR

1. Utilizar las herramientas indicadas en las instrucciones de montaje y seguir éstas últimas.
2. Es conveniente que todos los dispositivos de ensamblaje estén siempre adecuadamente apretados y periódicamente verificados, y vueltos a apretar si fuera necesario.
3. El posicionamiento y el medio de acceso a la cama vienen indicados en las instrucciones.
4. Respetar el grosor máximo del colchón, ver el marcado en las instrucciones de montaje.
5. Dimensiones del colchón recomendado 1980 X 880 X 150 máximo.
6. Será conveniente no utilizar la cama sobreelevada si una parte de la estructura faltara o estuviera rota
7. Las camas sobreelevadas no son aptas para los niños menores de 6 años, pues se pueden lesionar a causa de las caídas
8. Cuidado con los artículos tales como cuerdas, cordeles, arneses y cinturones atados o colgados en una cama superpuesta o sobreelevada para evitar que los niños se estrangulen.
9. Advertencia "los niños pueden verse pillados entre la cama y la pared. Para evitar el riesgo de lesiones graves, la distancia entre la barrera de seguridad superior y la pared no debe sobrepasar los 75 mm o debe ser de al menos 230 mm"
10. Conforme a la norma europea EN747-1 de 2007.
11. No dejar nunca los niños sin un mínimo de vigilancia.
12. No se debe permitir ningún juego violento en la cama de arriba ni debajo de ésta.
13. Está prohibido que haya más de una persona en la cama de arriba.
14. No permitir a los niños voltearse o saltar encima o debajo de la cama.
15. Utilizar siempre la escalera para subir y bajar de la cama de arriba.
16. No sustituir las piezas originales por sustituciones. Pedir las piezas de repuesto dirigiéndose a la tienda o al fabricante.
17. La utilización de una lamparilla de noche puede proporcionar más seguridad al niño que se acuesta en la cama de arriba.

P. Instruções de utilização

IMPORTANTE – LER COM ATENÇÃO – GUARDAR PARA REFERÊNCIA FUTURA

1. Utilizar as ferramentas indicadas no folheto de montagem e seguir as instruções de montagem.
2. Todos os dispositivos de montagem devem estar correctamente apertados e verificados regularmente, se necessário apertar novamente.
3. O posicionamento e o meio de acesso à cama estão indicados no folheto de montagem.
4. Respeitar a espessura máxima do colchão, ver as especificações no folheto de montagem.
5. Tamanho do colchão recomendado 1980 X 880 X 150 no máximo.
6. Não deve utilizar a cama alta quando falta uma parte da estrutura ou quando esta está quebrada
7. As camas altas não são adequadas para crianças com menos de 6 anos, devido aos riscos de ferimentos causados pelas quedas
8. Ter cuidado com os artigos tais como as cordas, fios, atacadores, arreios e cintos fixados ou atados numa cama alta ou beliche por forma a prevenir o risco de estrangulamento.
9. Aviso «As crianças podem ficar bloqueadas entre a cama e a parede. Para prevenir o risco de ferimentos graves, a distância entre a barreira de segurança superior e a parede não deve exceder 75 mm ou deve ser de pelo menos 230 mm»
10. Conforme à norma europeia EN747-1 de 2007.
11. Nunca deixar as crianças sem vigilância
12. Nenhum jogo brutal deve ser permitido em cima e debaixo da cama alta.
13. É proibido haver mais de que uma pessoa na cama alta.
14. Não deixar as crianças empurrar-se ou saltar em cima ou debaixo da cama.
15. Utilizar sempre a escada para subir ou descer da cama alta.
16. Não substituir as peças de origem por outras peças. Obter as peças sobresselentes na loja ou no fabricante.
17. A utilização de um candeeiro pode trazer mais segurança à criança que dorme na cama alta.

NL. Gebruiksaanwijzing

BELANGRIJK – AANDACHTIG LEZEN – BEWAREN VOOR LATERE NASLAG

1. Gebruik het op de montagehandleiding aangegeven gereedschap en volg de assemblage-instructies.
2. Alle bevestigingsmiddelen van de assemblage moeten behoorlijk zijn vastgedraaid, regelmatig worden gecontroleerd en zonodig opnieuw worden aangehaald.
3. De plaatsing en de wijze van toegang tot het bed zijn op de montagehandleiding aangegeven.
4. Hou u aan de maximale matrasdikte, zie de markering op de montagehandleiding.
5. Aanbevolen matrasdikte: maximum 1980 X 880 X 150 .
6. Het hoge bed moet niet gebruikt worden, wanneer een deel van de structuur ontbreekt of kapot is.
7. Hoge bedden zijn niet geschikt voor kinderen onder de 6 jaar, vanwege het gevaar van verwondingen door vallen.
8. Wees voorzichtig met dingen als koorden, touwtjes, snoeren, tuigjes en gordels die vastgemaakt zijn aan een hoog bed, om te voorkomen dat kinderen gekeeld worden en stikken.
9. Waarschuwing «Kinderen kunnen klem raken tussen het bed en de muur. Om ernstige verwondingen te voorkomen, moet de afstand tussen de bovenste veiligheidsstang en de muur niet meer zijn dan 75 mm of minstens 230 mm»
10. Voldoet aan de Europese norm EN747-1 van 2007.
11. Laat kinderen nooit alleen zonder minimale bewaking
12. Verbied woeste spellen in en onder een verhoogd bed.
13. Er mag zich maar één persoon tegelijk in het hoge bed bevinden.
14. Laat kinderen niet wippen of springen in of onder het hoge bed.
15. Gebruik altijd de ladder om in en uit het hoge bed te klimmen.
16. Vervang de originele stukken niet door namaak. Betrek de vervangende onderdelen van uw leverancier of van de fabrikant.
17. Het gebruik van een nachtlampje kan kinderen in een verhoogd bed een veilig gevoel geven.

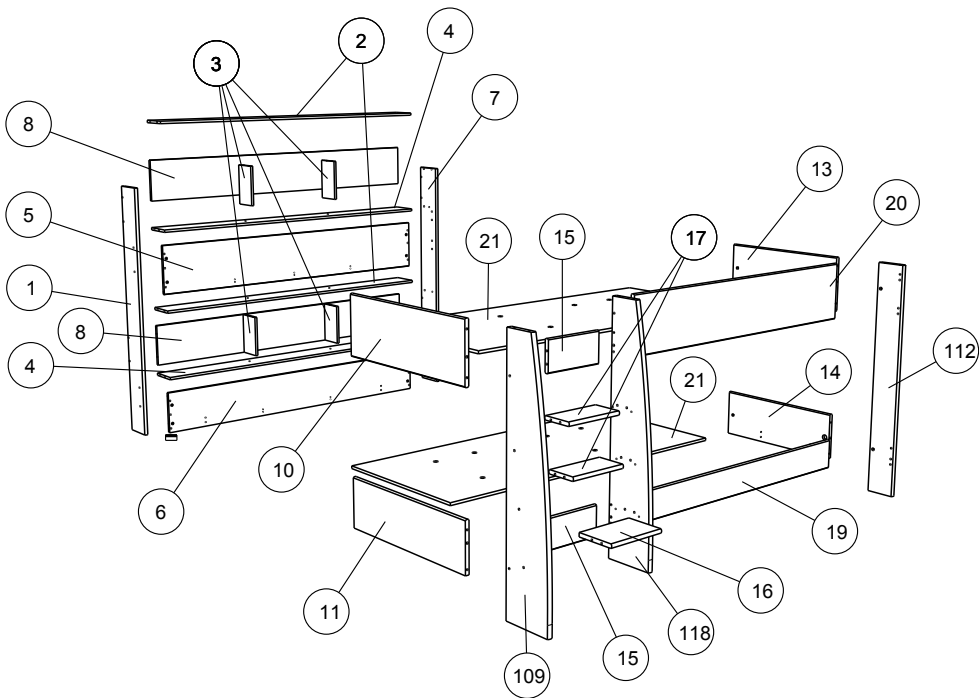

| Rep | Qty | Dimensions mm | | | Size inch | | |
|-----|-----|---------------|-----|----|-----------|----------|--------|
| | | | | | | | |
| 3 | 4 | 272 | 161 | 16 | 10 23/32 | 6 11/32 | 5/8 |
| 15 | 2 | 332 | 169 | 22 | 13 1/16 | 6 21/32 | 7/8 |
| 17 | 2 | 332 | 169 | 22 | 13 1/16 | 6 21/32 | 7/8 |
| 16 | 1 | 332 | 214 | 22 | 13 1/16 | 8 7/16 | 7/8 |
| 14 | 1 | 770 | 270 | 22 | 30 5/16 | 10 5/8 | 7/8 |
| 13 | 1 | 770 | 320 | 22 | 30 5/16 | 12 19/32 | 7/8 |
| 11 | 1 | 891 | 270 | 22 | 35 3/32 | 10 5/8 | 7/8 |
| 10 | 1 | 891 | 320 | 22 | 35 3/32 | 12 19/32 | 7/8 |
| 112 | 1 | 1340 | 160 | 28 | 52 3/4 | 6 5/16 | 1 3/32 |
| 109 | 1 | 1340 | 277 | 28 | 52 3/4 | 10 29/32 | 1 3/32 |
| 118 | 1 | 1340 | 277 | 28 | 52 3/4 | 10 29/32 | 1 3/32 |
| 19 | 1 | 1638 | 169 | 22 | 64 1/2 | 6 21/32 | 7/8 |
| 20 | 1 | 1638 | 320 | 22 | 64 1/2 | 12 19/32 | 7/8 |
| 1 | 1 | 1649 | 189 | 22 | 64 29/32 | 7 7/16 | 7/8 |
| 7 | 1 | 1649 | 189 | 22 | 64 29/32 | 7 7/16 | 7/8 |
| 21 | 2 | 1990 | 890 | 16 | 78 11/32 | 35 1/32 | 5/8 |
| 8 | 2 | 2047 | 272 | 16 | 80 19/32 | 10 23/32 | 5/8 |
| 2 | 2 | 2048 | 183 | 16 | 80 5/8 | 7 7/32 | 5/8 |
| 4 | 2 | 2048 | 183 | 16 | 80 5/8 | 7 7/32 | 5/8 |
| 6 | 1 | 2048 | 277 | 16 | 80 5/8 | 10 29/32 | 5/8 |
| 5 | 1 | 2048 | 330 | 16 | 80 5/8 | 13 | 5/8 |

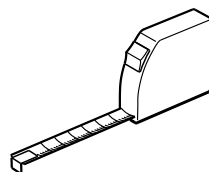

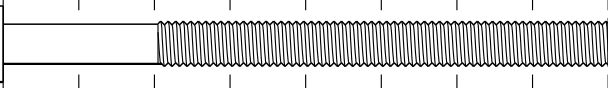
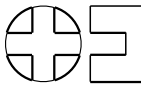
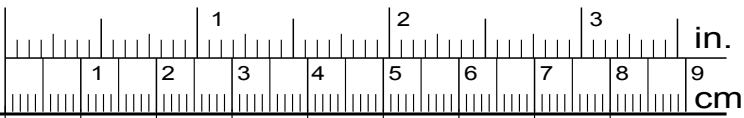

XT x 2

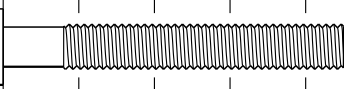
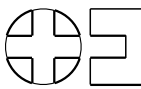

VV x 4



Ai x 8

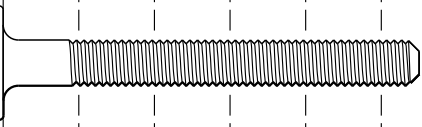
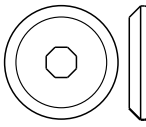

BLZ x 24

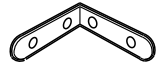

LN x 22

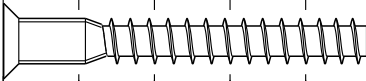

HW x 16



AP x 42



WA x 12



ADM x 12



VW x 6

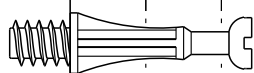

AD x 8



HV x 1

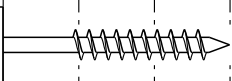

WH x 4



AHX x 30

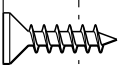

Vi x 82



ADP x 6



AJG x 3

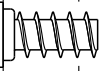

VB x 28



BML x 20

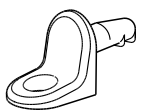

BAG x12

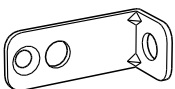

BLL x 2

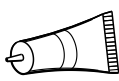

CF x 3



BLJ x 4

1

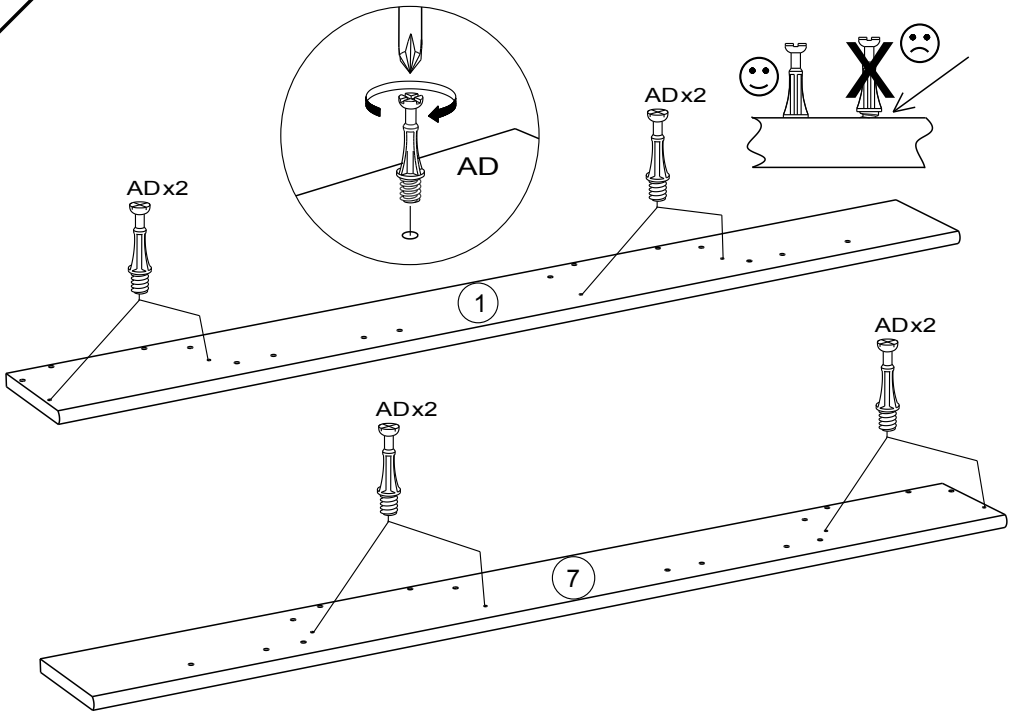

2

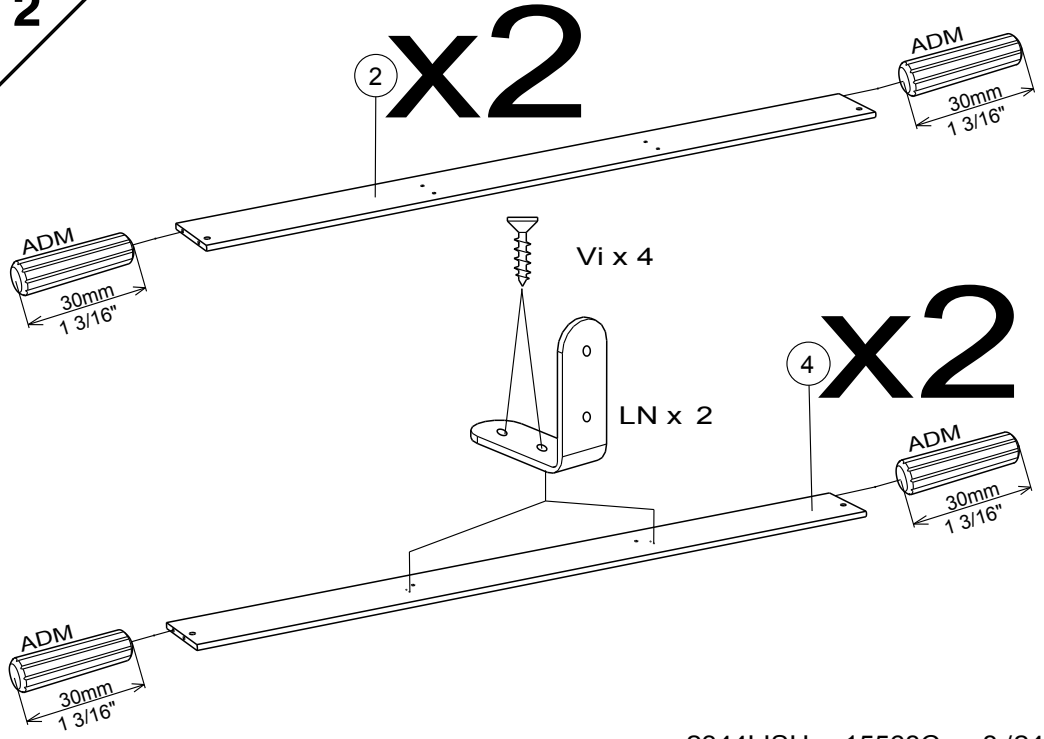

3

x4

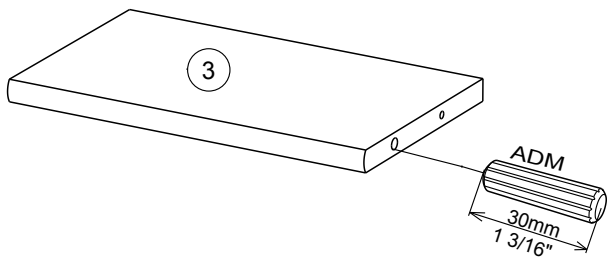

4

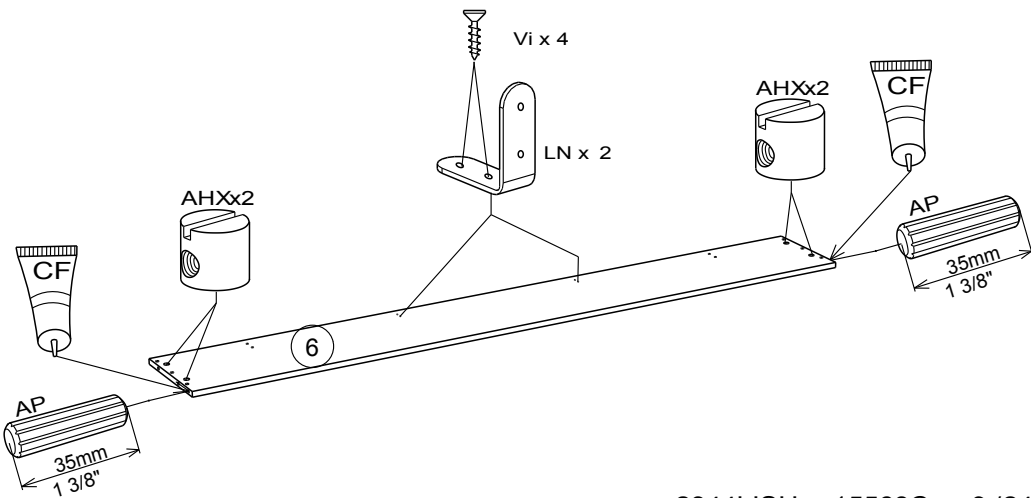
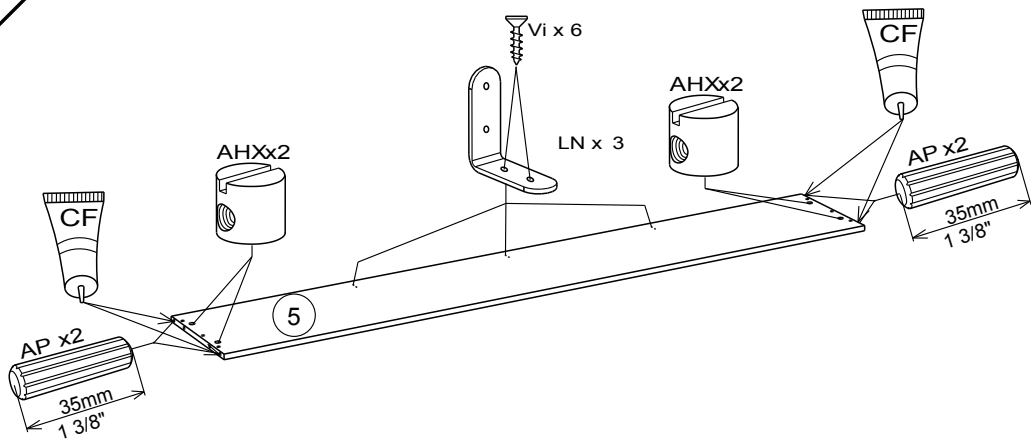

5

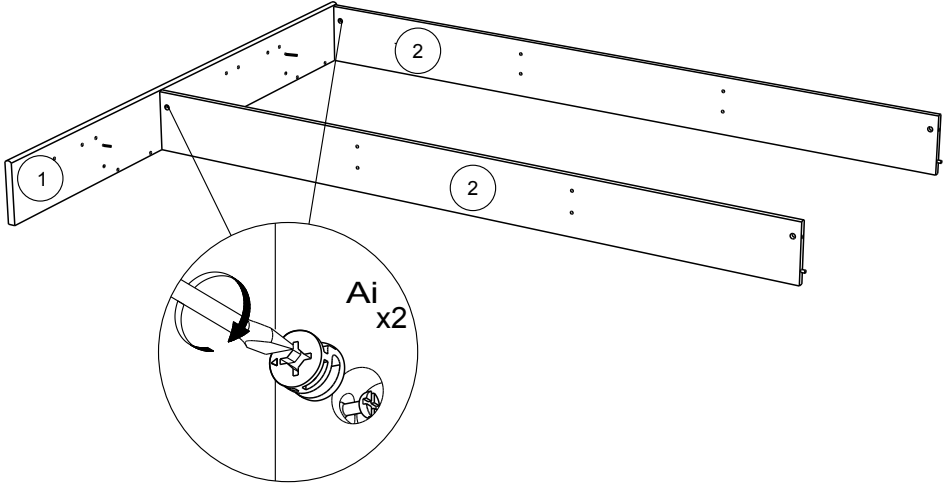

6

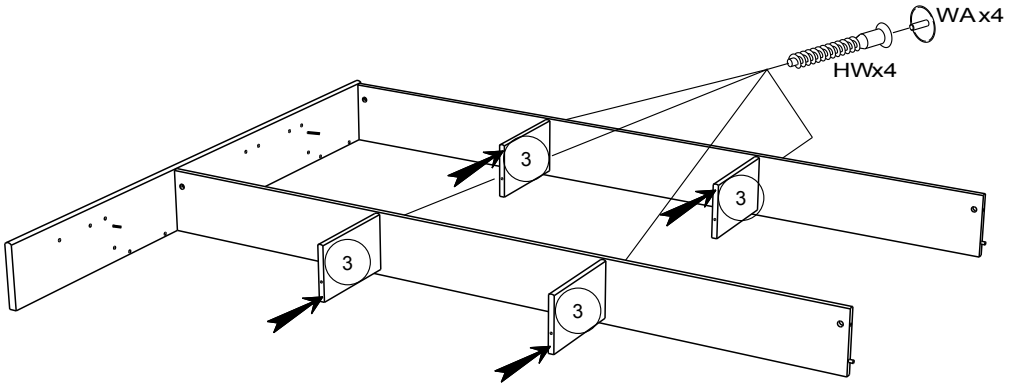

7

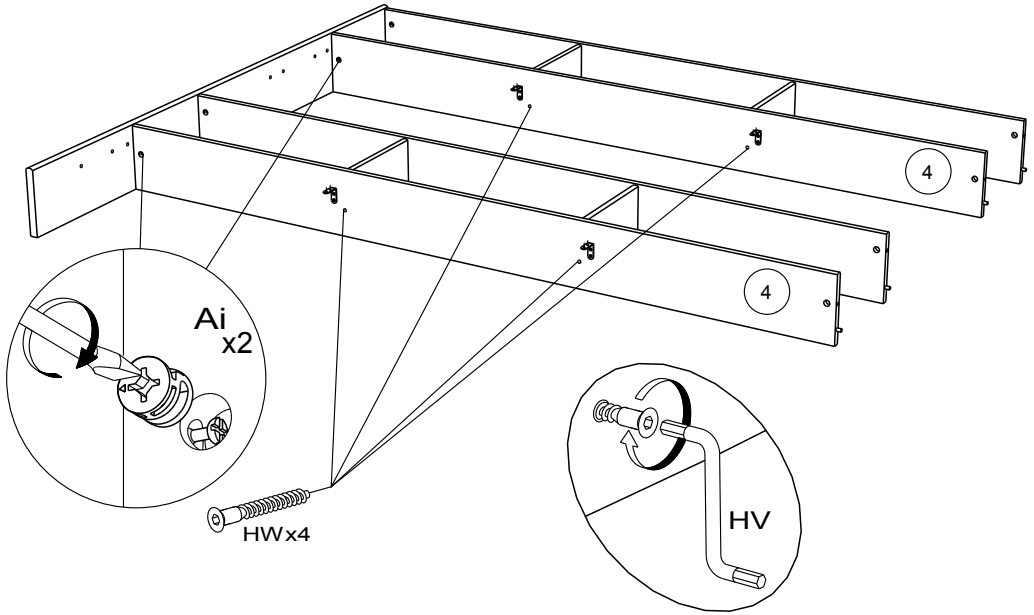

8

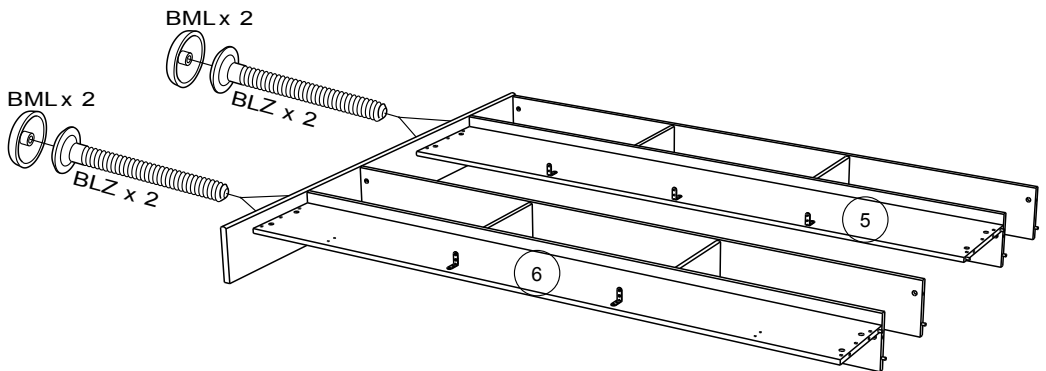

9

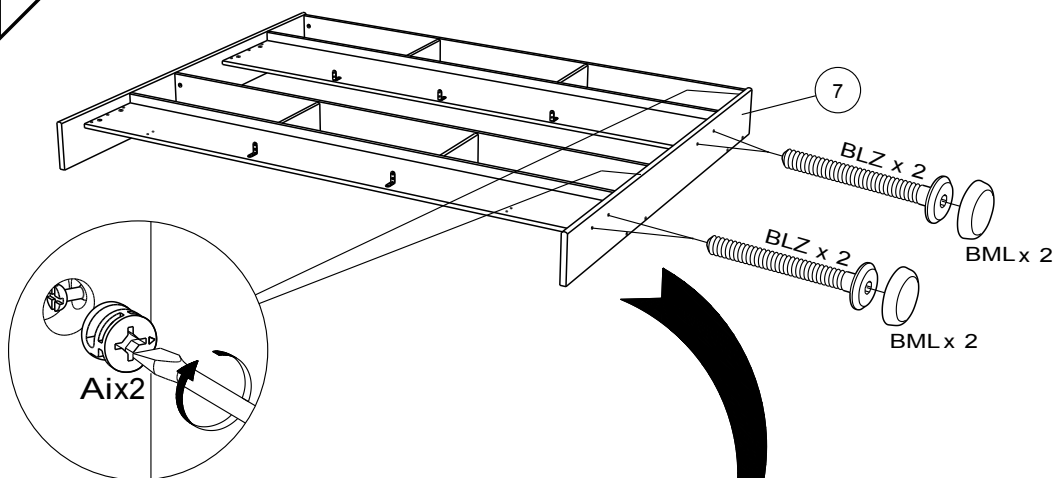

10

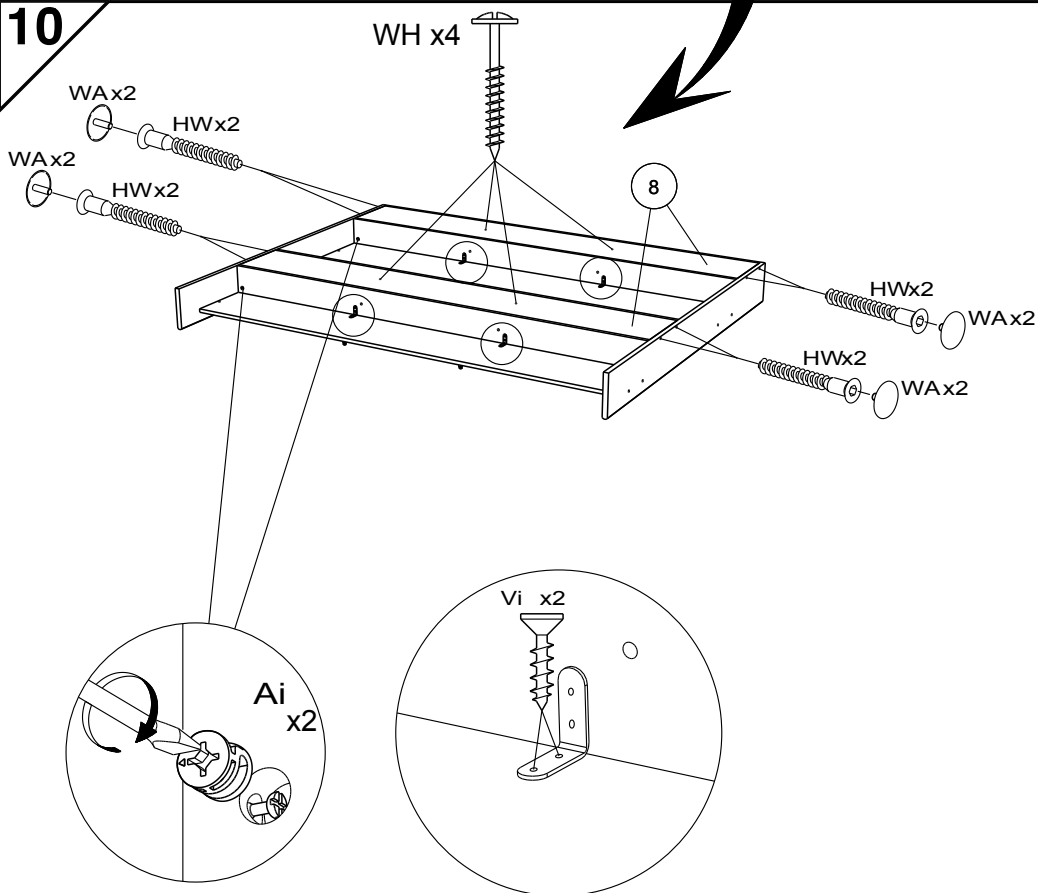

11

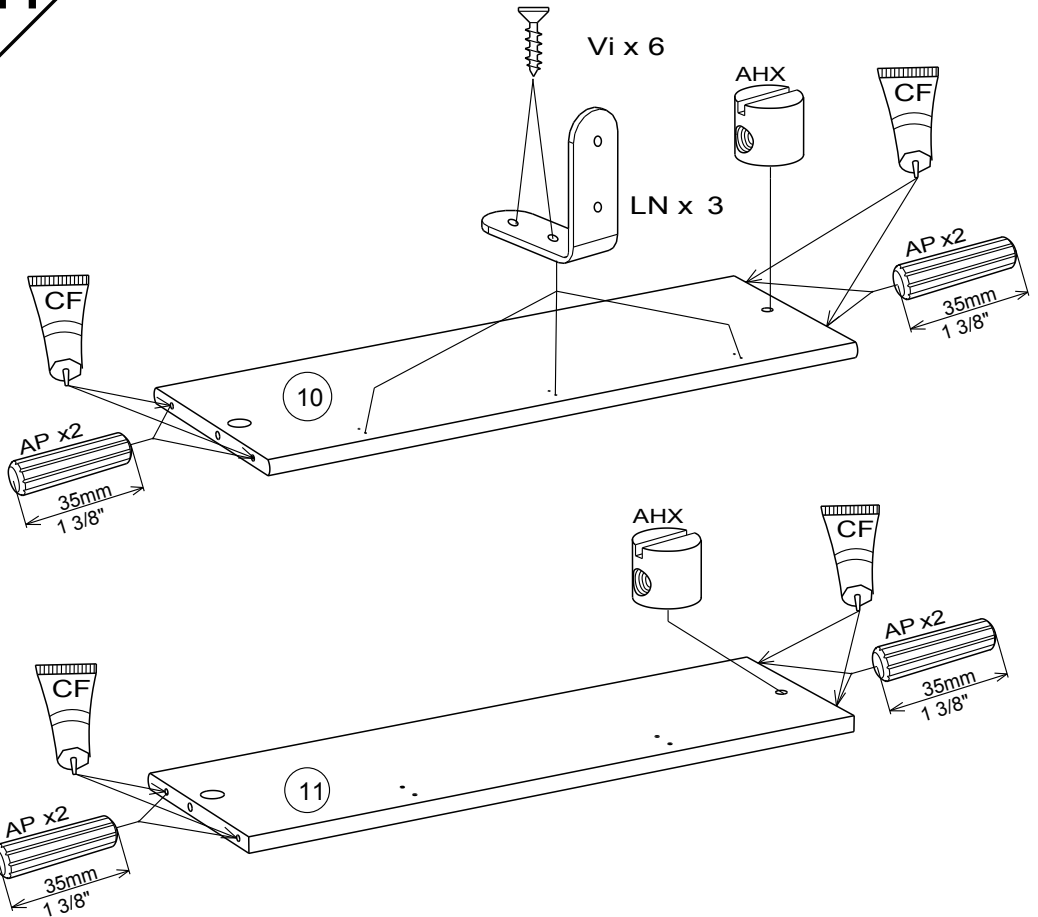

12

VISSER VV DE 2 TOURS

- ⊕ SCREW VV DOUBLE TOUR
- ⊕ DREHUNGEN SCHRAUBEN VV
- ⊕ TORNILLAR VV DE DOS VUELTAS
- ⊕ PARAFUSAR VV DE 2 VOLTAS
- ⊕ VOITARE VV DI 2 GIRI
- ⊕ SPON VV AAN MIT 2 TAREN

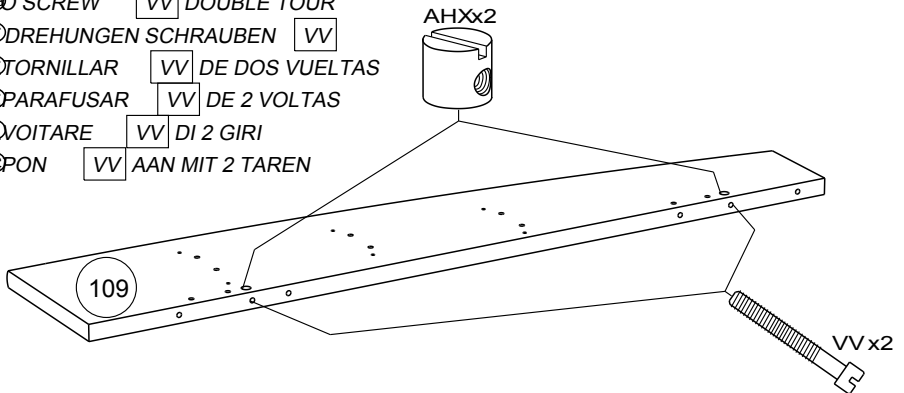

13

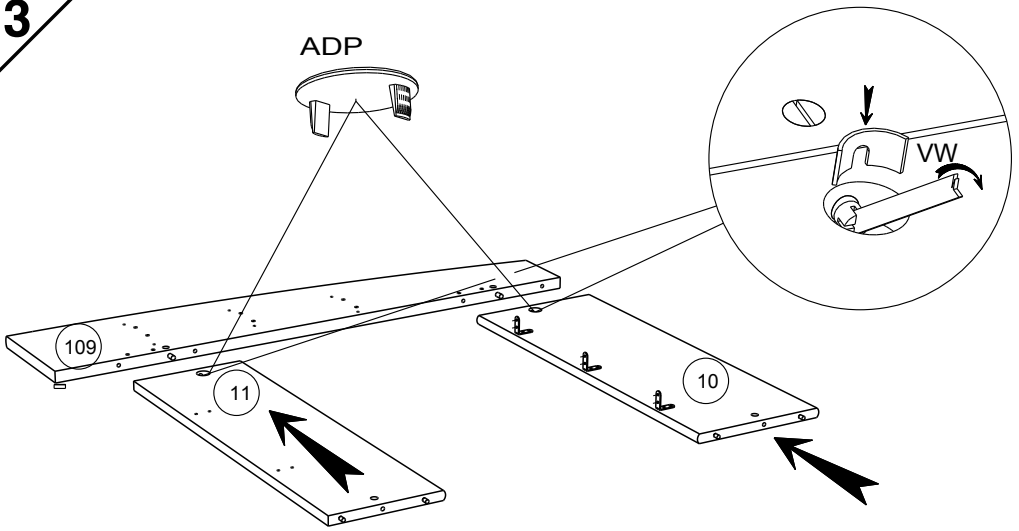

14

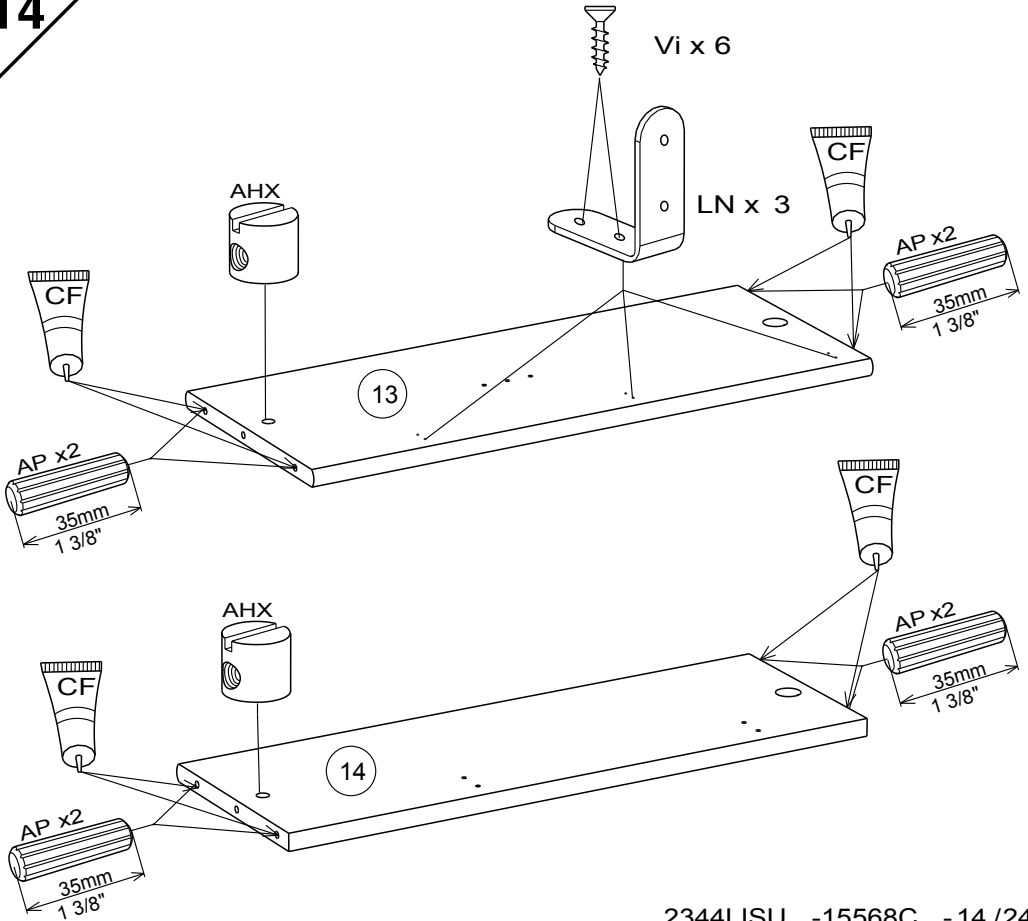

15**VISSER VV DE 2 TOURS**

- ⊕ SCREW VV DOUBLE TOUR
- ⊕ DREHUNGEN SCHRAUBEN VV
- ⊕ TORNILLAR VV DE DOS VUELTAS
- ⊕ PARAFUSAR VV DE 2 VOLTAS
- ⊕ VOITARE VV DI 2 GIRI
- ⊕ SPON VV AAN MIT 2 TAREN

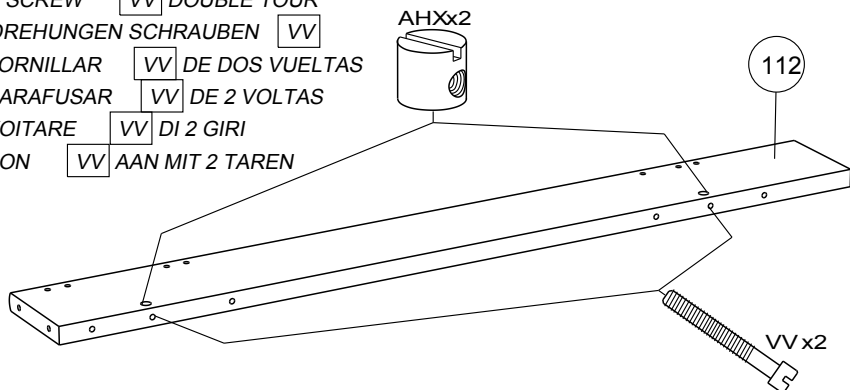
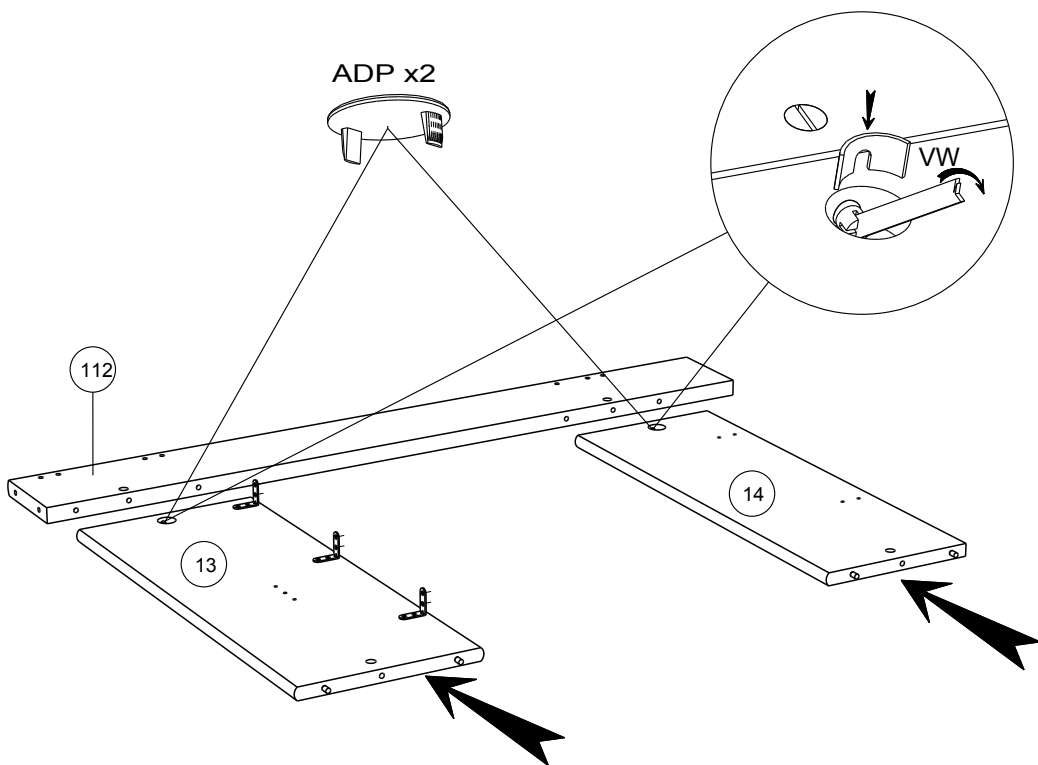
**16**

17

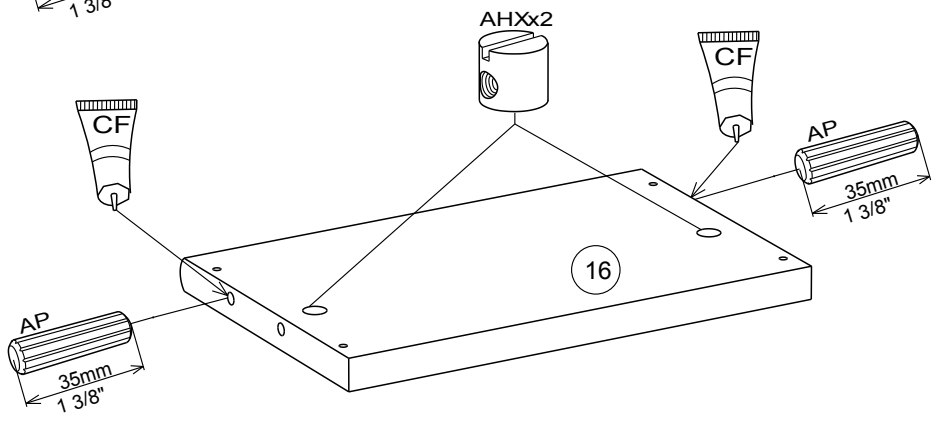
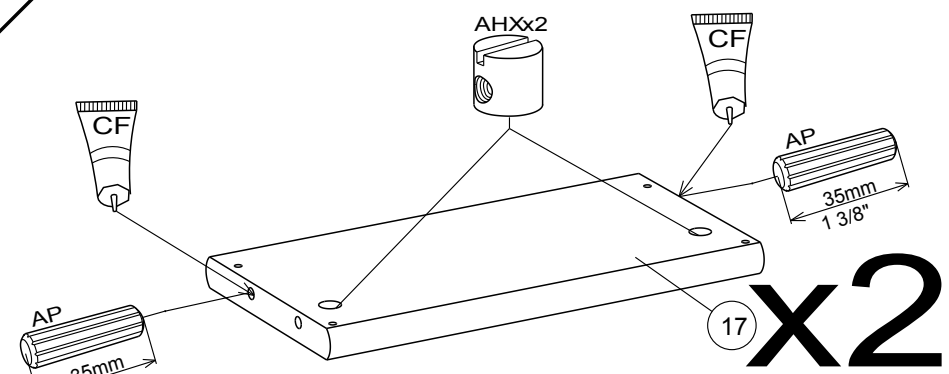

18

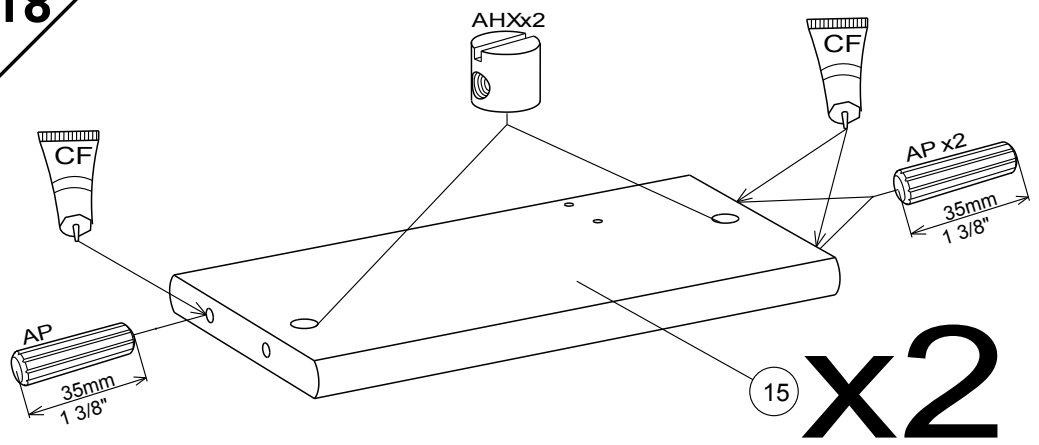

19

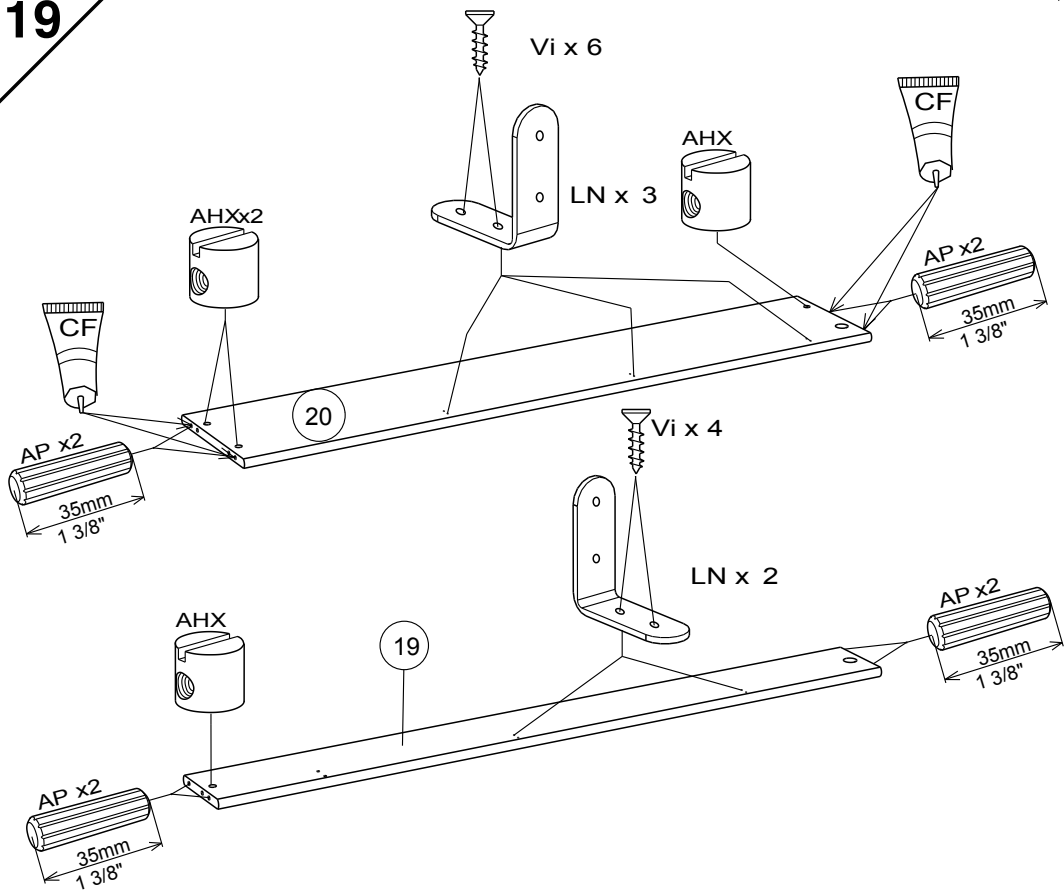

20

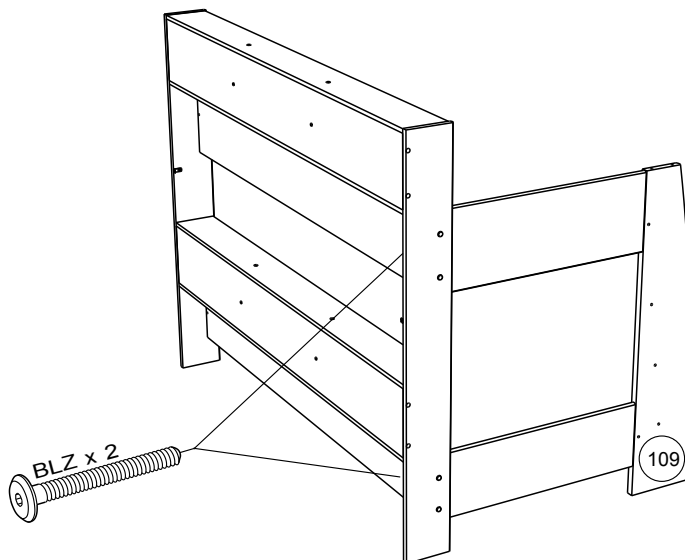

21

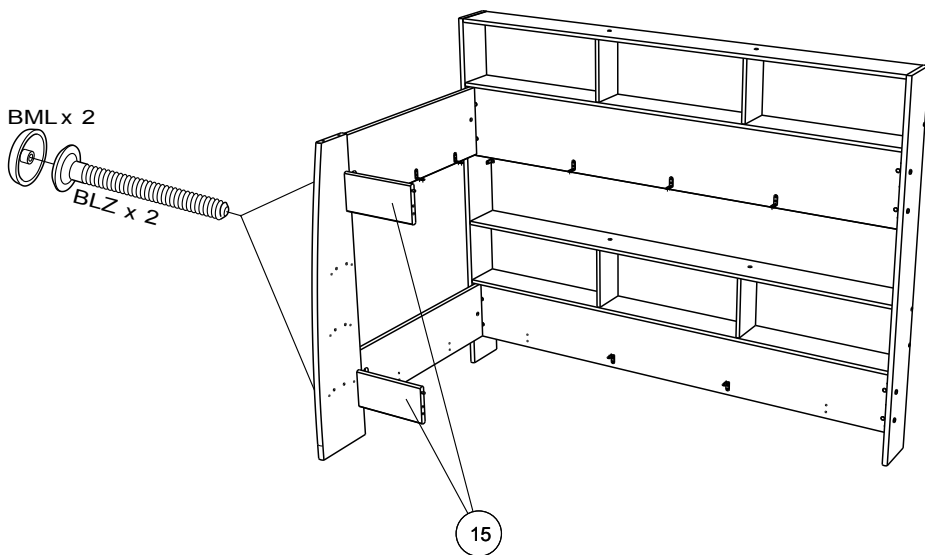

22

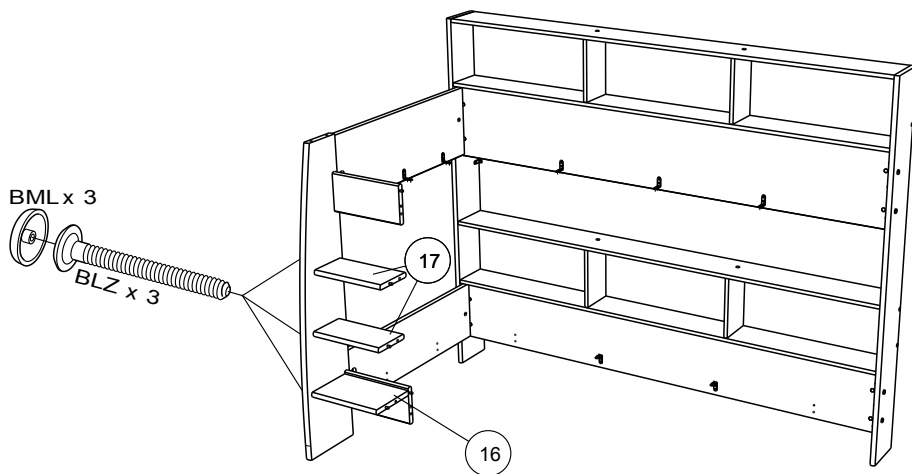

23

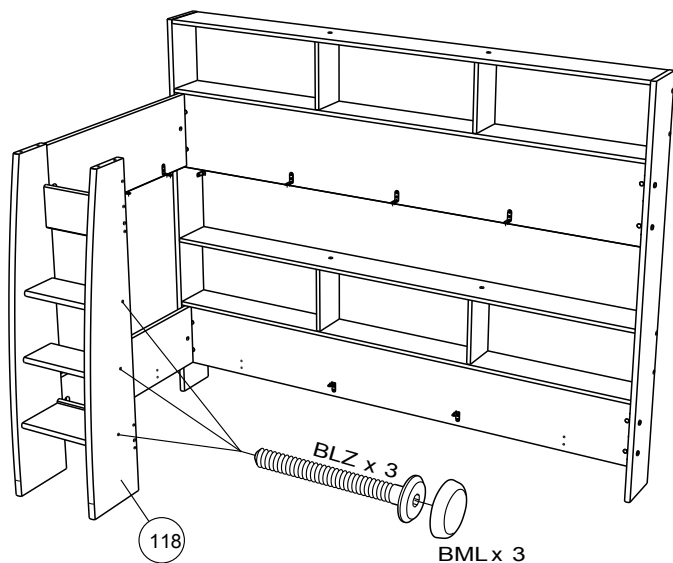

24

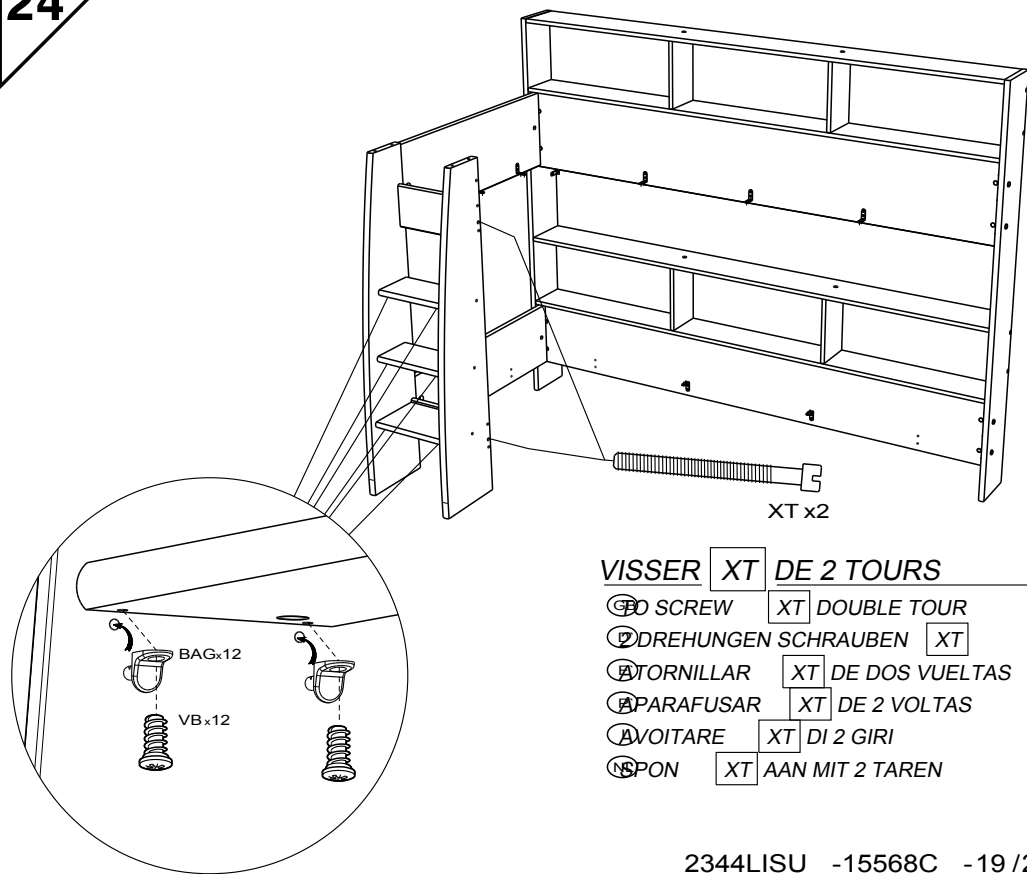

VISSER XT DE 2 TOURS

- ① SCREW XT DOUBLE TOUR
- ② DREHUNGEN SCHRAUBEN XT
- ③ TORNILLAR XT DE DOS VUELTAS
- ④ PARAFUSAR XT DE 2 VOLTAS
- ⑤ AVOITARE XT DI 2 GIRI
- ⑥ NSPON XT AAN MIT 2 TAREN

25

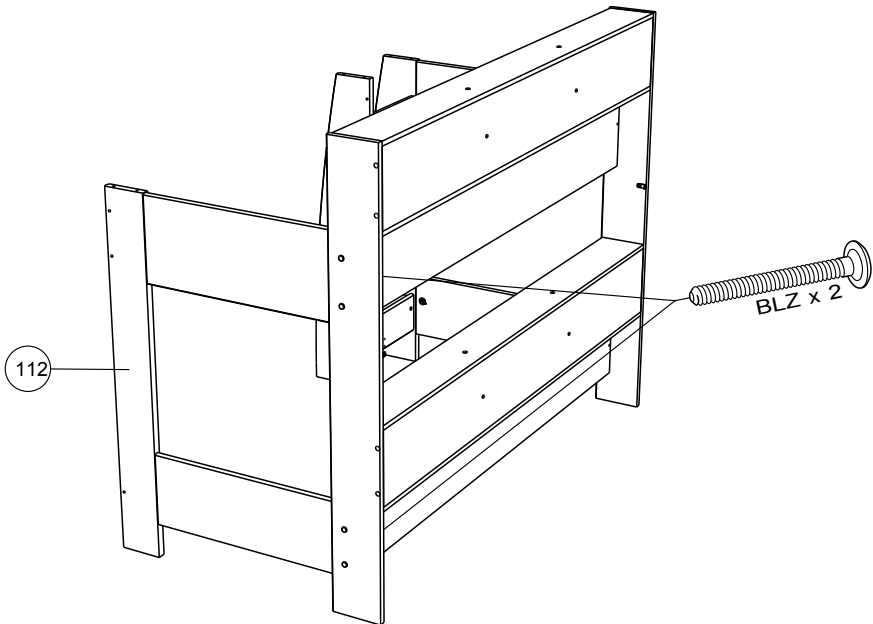

26

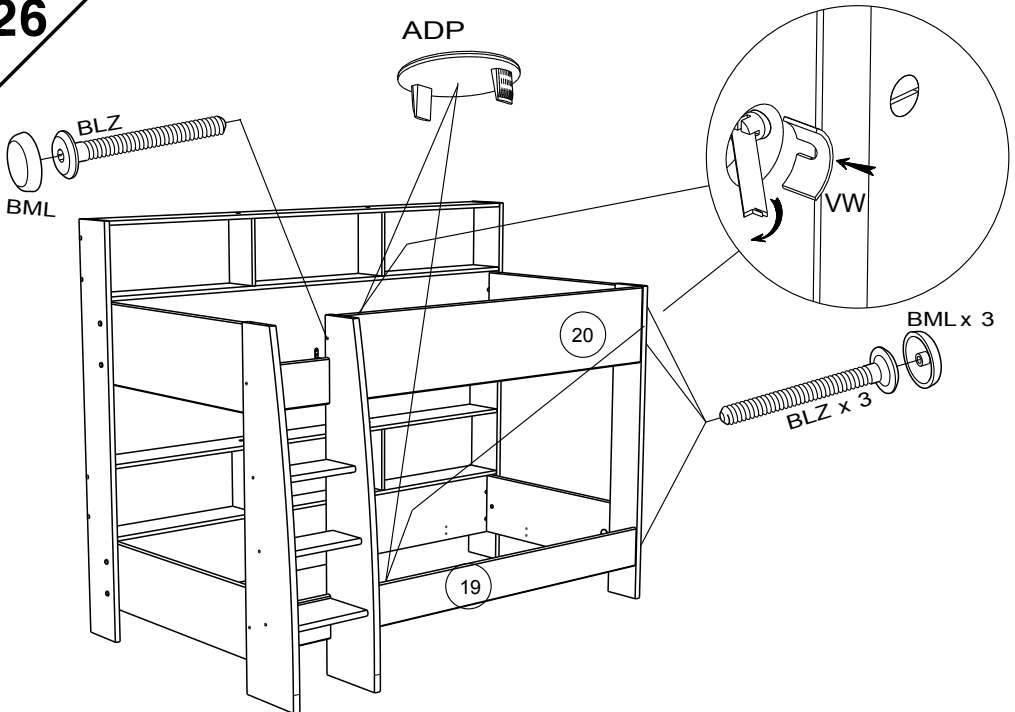

27

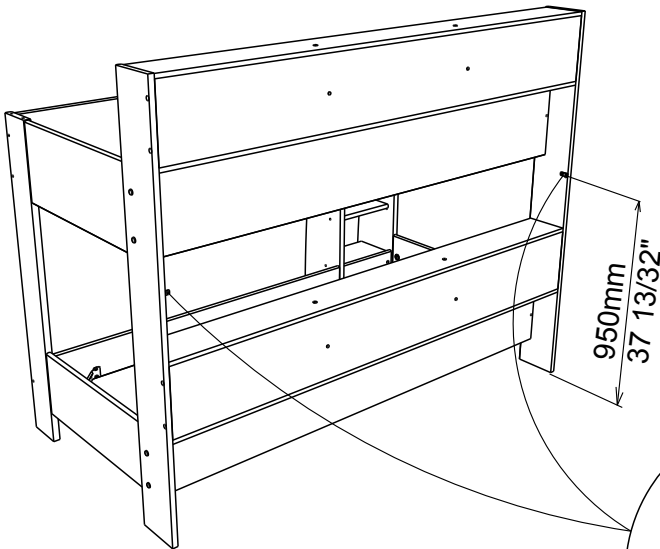
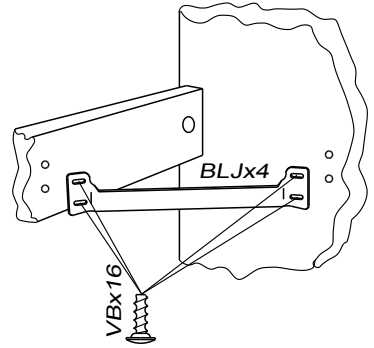
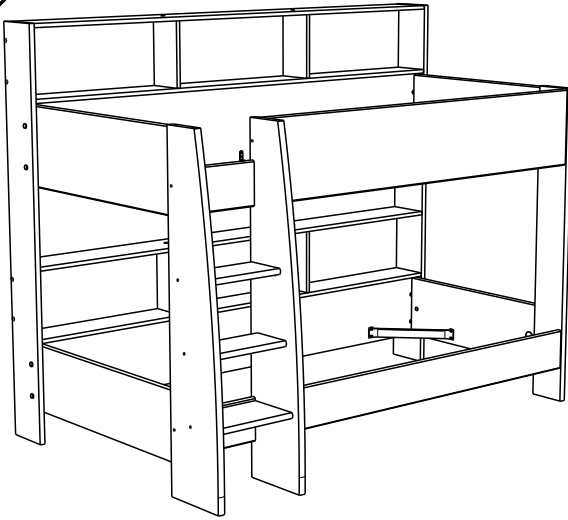

X2

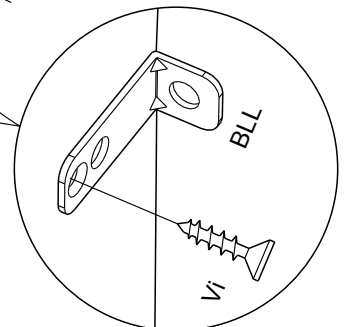

28

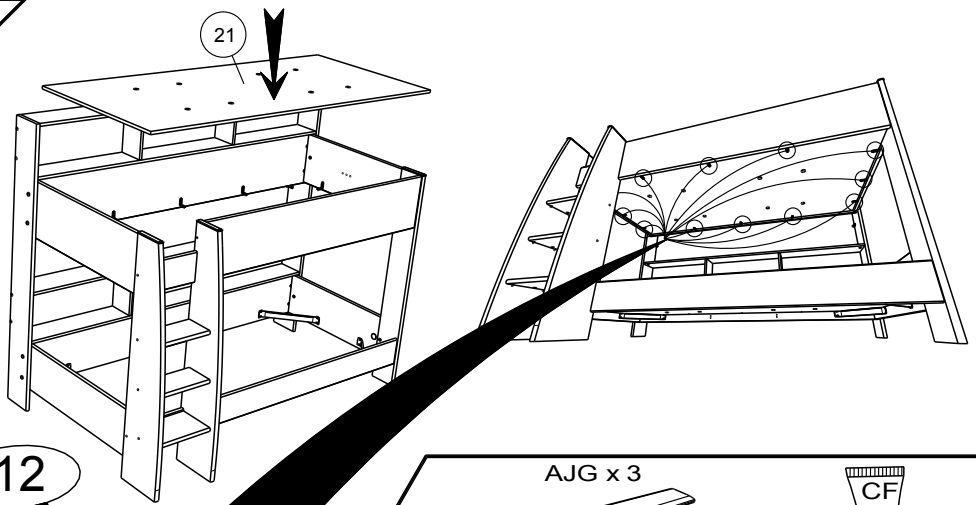

x12

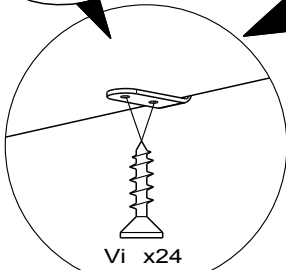

Vi x24

29

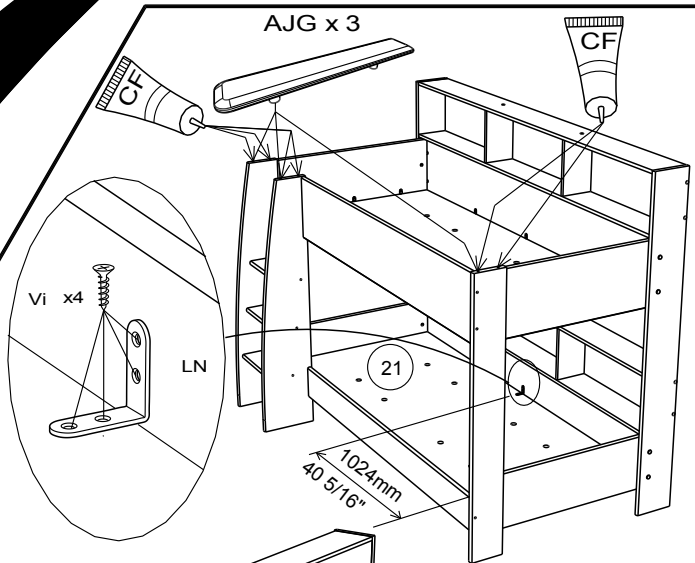

AJG x 3

CF

Vi x4

LN

1024mm
40 5/16"

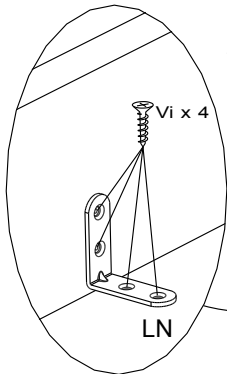

Vi x4

LN

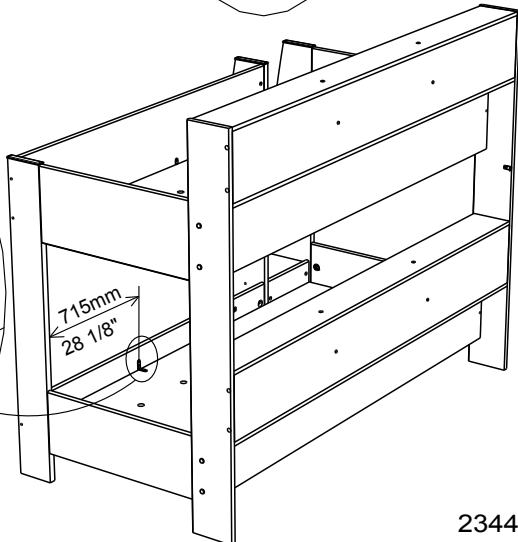

715mm
28 1/8"

LA FACE SUPERIEURE DU MATELAS
NE DOIT PAS SE TROUVER AU DESSUS
DE LA MARQUE FAITE SUR LE LIT

- Ⓒ**THE TOP SIDE OF THE MATTRESS**
MUST NOT BE ABOVE THE MARK
INDICATED ON THE BED
- Ⓓ**DIE OBERSEITE DER MATRATZE DARF**
SICH NICHT UBER DER AUF DEM BETT
ANGEGEBENEN MARKIERUNG BEFINDEN
- Ⓔ**LA CARA SUPERIOR DEL COLCHON**
DEBE ESTAR ENCIMA DE LA MARCA
HECHA EN LA CAMA
- Ⓕ**A PARTE SUPERIOR DO COLCHAO**
NAO DEVE ESTAR EM CIMA
DA MARCA FEITA NA CAMA
- Ⓖ**LA FACCIA SUPERIORE DEL MATERASSO**
NON DEVE ESSERE AL DISOPRA
DEL MARCHIO FATTO SUL LETTO
- Ⓗ**DE BOUENKANT VAN DE MATRAS**
MAG MET MERRTEREN OP HET
BED NIET OVERSCHRYDEN

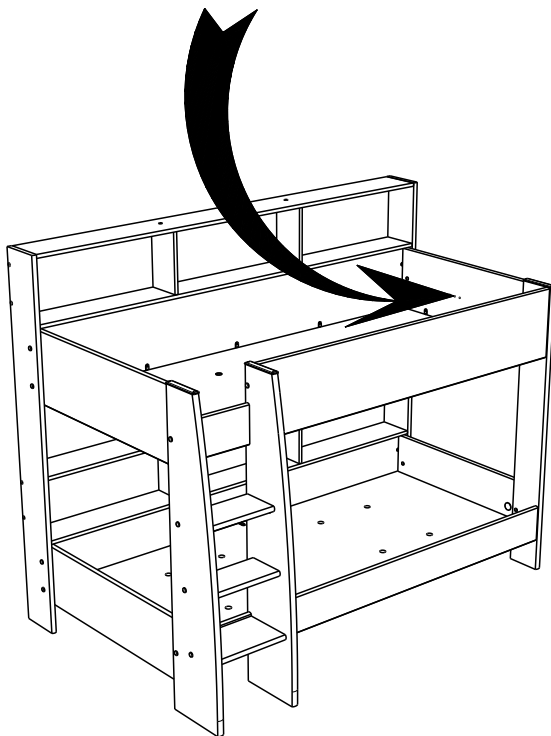

PARISOT MEUBLES
70800 SAINT LOUP SUR SEMOUSE (FRANCE)
CONFORME AUX EXIGENCES DE SECURITE

ⒸOMPLY WITH THE SECURITY STANDARDS
ⒹEMAB DEN SICHERHEITSNORMEN
ECONFORME A LAS EXIGENCIAS DE SEGURIDAD
PEM CONFORMIDADE COM AS EXIGENCIAS DE SEGURANCA
I CONFORME ALLE ESIGENZE DI SICUREZZA
NCONFORM DE VEILIGHEIDSVEREISTEN

- (F) Attention pour votre sécurité, ne pas dépasser les charges maxi
- (GB) Take care not to exceed the maximum safety load
- (D) Zu Ihrer Sicherheit niemals die maximale Belastung überschreiten
- (E) Tenga cuidado por su seguridad y no exceda las cargas máximas.
- (P) Atenção, para a sua segurança, não exceder as cargas máximas.
- (I) Per la vostra sicurezza non superare mai il carico massimo consentito.
- (NL) Voor uw veiligheid: nooit de maximale belasting overschrijden.

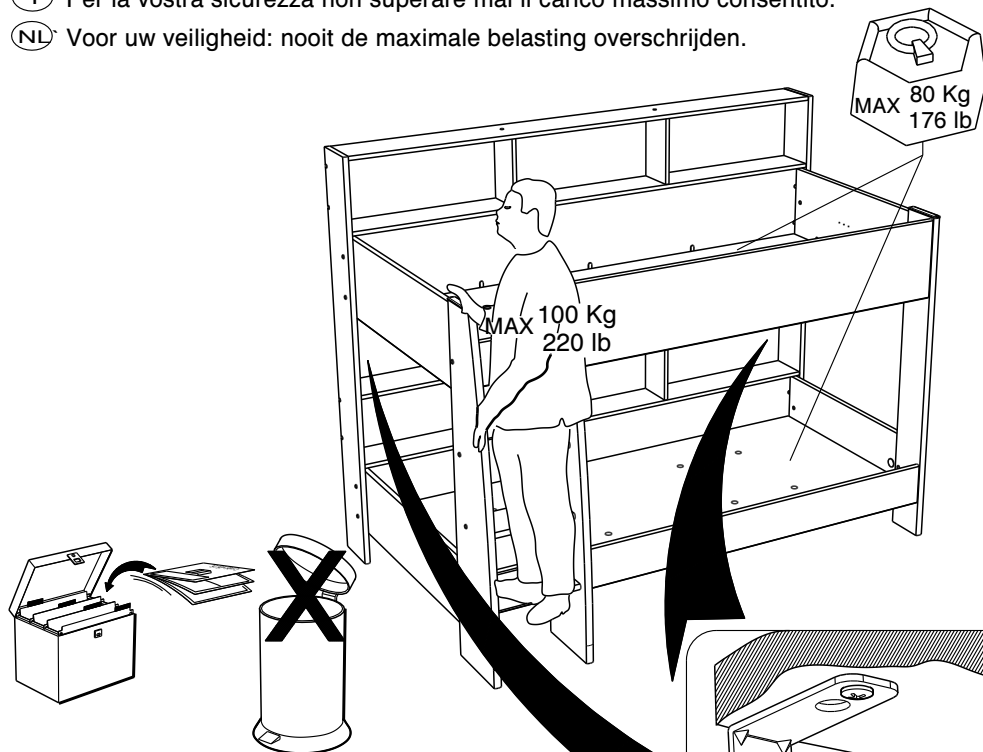

(FR) Pour votre sécurité : Fixation du meuble au mur
Attention, la fixation doit être réalisée par une personne compétente car cela nécessite des chevilles adaptées à la nature de votre mur.

(GB) For your own safety: attach the furniture to the wall
Important! The furniture must be attached by a qualified person using dowels that are suited to the type of wall.

(D) Für Ihre Sicherheit: Befestigung des Möbelstücks an der Wand
Achtung, die Befestigung muss von einem Fachmann vorgenommen werden, weil sie an die Wand angepasste Dübel erfordert.

(E) Para su seguridad: Fijación del mueble a la pared
¡Ojo! La fijación deberá llevarla a cabo una persona competente ya que necesitará unos tacos adaptados a tipo de pared.

(PT) Para a sua segurança: Fixação do móvel na parede
Atenção, a fixação deve ser efectuada por uma pessoa competente, pois exige a utilização de cavilhas adaptadas à natureza da parede.

(I) Per la vostra sicurezza: fissaggio del mobile alla parete.
Nota bene, il fissaggio deve essere eseguito da personale specializzato, poiché l'utilizzo di tasselli adatti alla parete.

(NL) Voor uw veiligheid: bevestiging van het meubel aan de muur.
Let op, de bevestiging moet worden uitgevoerd door een bevoegd persoon, want hiervoor zijn pluggen nodig die specifiek geschikt zijn voor de betreffende muur.

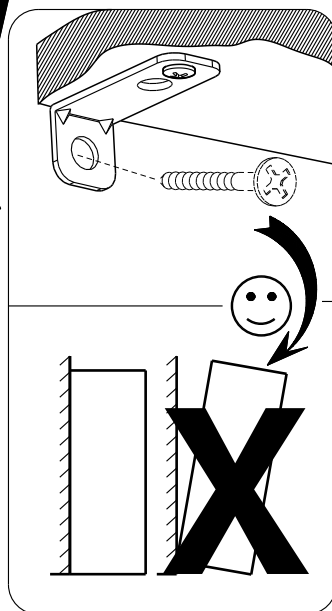

Please dispose of all packaging safely.

General Care & Maintenance

Wipe clean with a slightly damp cloth.
Avoid the use of all household cleaners and abrasives.

Periodically check all screw & fixings to ensure they are secure.
When moving your product, carefully lift into place. Never drag or push the pieces across the floor as this will cause damage to the joints and could result in failure to the product that will invalidate the warranty.

For more information on cleaning and product care visit:
<https://www.happybeds.co.uk/help-and-advice>

Notes

We've tried to make this product as easy to assemble as possible. In the unlikely event that you have problems putting it together or have damaged or missing pieces, please contact us by visiting:

<https://www.happybeds.co.uk/customer-service>



www.happybeds.co.uk

